

# Models C-Series: C-20, C-24, C-2400

TORSION

COMMERCIAL  
STANDARD LIFT

## INSTALLATION INSTRUCTIONS AND OWNER'S MANUAL

If you need assistance, please call 1-866-569-3799 (press Option 1) and follow the prompts to contact a customer service representative. They will be happy to handle any questions that you may have.

### Table Of Contents

<b>Pre-Installation</b>	<b>2</b>
Important Safety Instructions	2
Removing an Existing Door and Preparing the Opening	2
Package Contents	4
Door Section Identification	6
Tools Required	6
<b>Breakdown Of Parts</b>	<b>7</b>
<b>Door Installation Instructions</b>	<b>8</b>
<b>Counterbalance Installation Instructions</b>	<b>15</b>
<b>Optional Installation</b>	<b>24</b>
Trolley Arm Hookup	24
Inside Lock	24
Step Plate	24
Exhaust Port	24
Mini Warehouse Lock	25
Chain Hoist	25
Pusher Springs	25
<b>Maintenance</b>	<b>27</b>
Cleaning Your Garage Door	27
Surface Preparation For Painting	27
Painting Your Garage Door	27
Operation And Maintenance	27
<b>Warranty</b>	<b>29</b>

### IMPORTANT NOTICES!

To avoid possible injury, read and fully understand the enclosed instructions carefully before installing and operating the garage door. Pay close attention to all warnings and notes. After installation is complete, fasten this manual near garage door for easy reference.

This Installation document is available at no charge from:

- Your local Wayne Dalton Sales Center, or
- Online at [www.Wayne-Dalton.com](http://www.Wayne-Dalton.com), or
- By mailing to: Wayne Dalton, a division of Overhead Door Corporation, P.O. Box 67, Mt. Hope, OH., 44660

## Important Safety Instructions

**DEFINITION OF KEY WORDS USED IN THIS MANUAL:**

### **WARNING**

INDICATES A POTENTIALLY HAZARDOUS SITUATION WHICH, IF NOT AVOIDED, COULD RESULT IN SEVERE OR FATAL INJURY.

### **CAUTION**

PROPERTY DAMAGE OR INJURY CAN RESULT FROM FAILURE TO FOLLOW INSTRUCTIONS.

**IMPORTANT:** REQUIRED STEP FOR SAFE AND PROPER DOOR OPERATION.

**NOTE:** Information assuring proper installation of the door.

**READ THESE INSTRUCTIONS CAREFULLY BEFORE ATTEMPTING INSTALLATION. IF IN QUESTION ABOUT ANY OF THE PROCEDURES, DO NOT PERFORM THE WORK. INSTEAD, HAVE A TRAINED DOOR SYSTEMS TECHNICIAN DO THE INSTALLATION OR REPAIRS.**

1. READ AND FOLLOW ALL INSTALLATION INSTRUCTIONS.
2. Wear protective gloves during installation to avoid possible cuts from sharp metal edges.
3. It is always recommended to wear eye protection when using tools, otherwise eye injury could result.
4. Avoid installing your new door on windy days. Door could fall during the installation causing severe or fatal injury.
5. Doors 12'-0" wide and over should be installed by two persons, to avoid possible injury.
6. Operate door only when it is properly adjusted and free from obstructions.
7. If a door becomes hard to operate, inoperative or is damaged, immediately have necessary adjustments and/ or repairs made by a trained door system technician using proper tools and instructions.
8. DO NOT stand or walk under a moving door, or permit anybody to stand or walk under an electrically operated door.
9. DO NOT place fingers or hands into open section joints when closing a door. Use lift handles/ gripping points when operating door manually.
10. DO NOT permit children to operate garage door or door controls. Severe or fatal injury could result should the child become entrapped between the door and the floor.
11. Due to constant extreme spring tension, do not attempt any adjustment, repair or alteration to any part of the door, especially to springs, spring brackets, bottom corner brackets, fasteners, counterbalance lift cables or supports. To avoid possible severe or fatal injury, have any such work performed by a trained door systems technician using proper tools and instructions.
12. On electrically operated doors, pull down ropes must be removed and locks must be removed or made inoperative in the open (unlocked) position.
13. Top section of door may need to be reinforced when attaching an electric opener. Check door and/ or opener manufacturer's instructions.
14. Visually inspect door and hardware monthly for worn and or broken parts. Check to ensure door operates freely.
15. Test electric opener's safety features monthly, following opener manufacturer's instructions.
16. NEVER hang tools, bicycles, hoses, clothing or anything else from horizontal tracks. Track systems are not intended or designed to support extra weight.
17. This door may not meet the building code wind load requirements in your area. For your safety, you will need to check with your local building official for wind load code requirements and building permit information.
18. For windloaded doors, the wind performance is achieved via the entire door system and component substitution is not authorized without express permission by Wayne Dalton.
19. For door heights greater than 10 feet or a door balance weight greater than 400 pounds, Chain Hoist or Motor Operator is recommended.

**NOTE:** It is recommended that 5/16" lag screws are pilot drilled using a 3/16" drill bit, prior to fastening.







### **CAUTION**

IF ANY PART OF THE DOOR IS TO BE INSTALLED ONTO PRESERVATIVE-TREATED WOOD, PTFE-COATED OR STAINLESS STEEL FASTENERS MUST BE OBTAINED AND USED. REPLACEMENT FASTENERS MUST BE OF AT LEAST EQUAL STRENGTH AND SIZE AS ORIGINAL FASTENERS. IF THE ORIGINAL FASTENER WAS RED-HEAD, THE REPLACEMENT FASTENER MUST BE RED-HEAD ALSO. CONTACT WAYNE DALTON FOR FASTENER STRENGTH VALUES IF NEEDED.

### **WARNING**

**IMPACT GUNS ARE NOT RECOMMENDED. WHEN INSTALLING 5/16" LAG SCREWS USING AN ELECTRIC DRILL/ DRIVER, THE DRILL/ DRIVERS CLUTCH MUST BE SET TO DELIVER NO MORE THAN 200 IN-LBS OF TORQUE. FASTENER FAILURE COULD OCCUR AT HIGHER SETTINGS.**

**IMPORTANT:** RIGHT AND LEFT HAND IS DETERMINED INSIDE THE BUILDING LOOKING OUT.

Potential Hazard	Effect	Prevention
  <p>Moving door</p>	 <b>WARNING</b> Could result in Death or Serious Injury	Keep people clear of opening while Door is moving.  Do <b>NOT</b> allow children to play with the Door Opener.  Do <b>NOT</b> operate a Door that jams or one that has a broken spring.
  <p>High tension spring</p>	 <b>WARNING</b> Could result in Death or Serious Injury	Do <b>NOT</b> try to remove, install, repair or adjust springs or anything to which door spring parts are fastened, such as, wood blocks, steel brackets, cables or other like items.  Installations, repairs and adjustments must be done by a trained door system technician using proper tools and instructions.

## Removing an Existing Door and Preparing the Opening

**IMPORTANT:** COUNTERBALANCE SPRING TENSION MUST ALWAYS BE RELEASED BEFORE ANY ATTEMPT IS MADE TO START REMOVING AN EXISTING DOOR.

### **WARNING**

**A POWERFUL SPRING RELEASING ITS ENERGY SUDDENLY CAN CAUSE SEVERE OR FATAL INJURY. TO AVOID INJURY, HAVE A TRAINED DOOR SYSTEMS TECHNICIAN, USING PROPER TOOLS AND INSTRUCTIONS, RELEASE THE SPRING TENSION.**

To avoid possible injury and to insure proper installation, it's highly recommended that you read and fully understand the complete instructions on removing an Existing Door & Preparing the Opening. These are available for download at [www.Wayne-Dalton.com](http://www.Wayne-Dalton.com) or at your local Wayne Dalton Sales Center.

**IMPORTANT:** IF YOU JUST REMOVED YOUR EXISTING DOOR OR YOU ARE INSTALLING A NEW DOOR, COMPLETE ALL STEPS IN PREPARING THE OPENING.

To ensure secure mounting of track brackets, side and center brackets, or steel angles to new or retro-fit construction, it is recommended to follow the procedures outlined in DASMA technical data sheets #156, #161 and #164 at [www.dasma.com](http://www.dasma.com).

The inside perimeter of your garage door opening should be framed with wood jamb and header material. The jambs and header must be securely fastened to sound framing members. It is recommended that 2" x 6" lumber be used. The jambs must be plumb and the header level. The jambs should extend a minimum of 12" (305 mm) above the top of the opening for Torsion counterbalance systems. For low headroom applications, the jambs should extend to the ceiling height.

Minimum side clearance required, from the opening to the wall, is 3-1/2" (89 mm), for 2" track.

Minimum side clearance required, from the opening to the wall, is 4-1/2" (114 mm), for 3" track.

**IMPORTANT:** CLOSELY INSPECT JAMBS, HEADER AND MOUNTING SURFACE. ANY WOOD

FOUND NOT TO BE SOUND, MUST BE REPLACED.

For Torsion counterbalance systems, a suitable mounting surface (2" x 6") must be firmly attached to the wall, above the header at the center of the opening.

**NOTE:** Drill a 3/16" pilot hole in the mounting surface to avoid splitting the lumber. Do not attach the mounting surface with nails.

**WEATHERSTRIPS (MAY NOT BE INCLUDED):**

Depending on the size of your door, you may have to cut or trim the weatherstrips (if necessary) to properly fit into the header and jambs.

**NOTE:** If nailing product at 40°F or below, pre-drilling is required.

**NOTE:** Do not permanently attach weatherstrips to the header and jambs at this time.

For the header, align the weatherstrip 1/8" to 1/4" inside the header edge, and temporarily secure it to the header with equally spaced nails. Starting at either side of the jamb, fit the weatherstrip up tight against the temporarily attached weatherstrip in the header and 1/8" to 1/4" inside the jamb edge. Temporarily secure the weatherstrip with equally spaced nails. Repeat for other side. This will keep the bottom section from falling out of the opening during installation. Equally space nails approximately 12" to 18" apart.

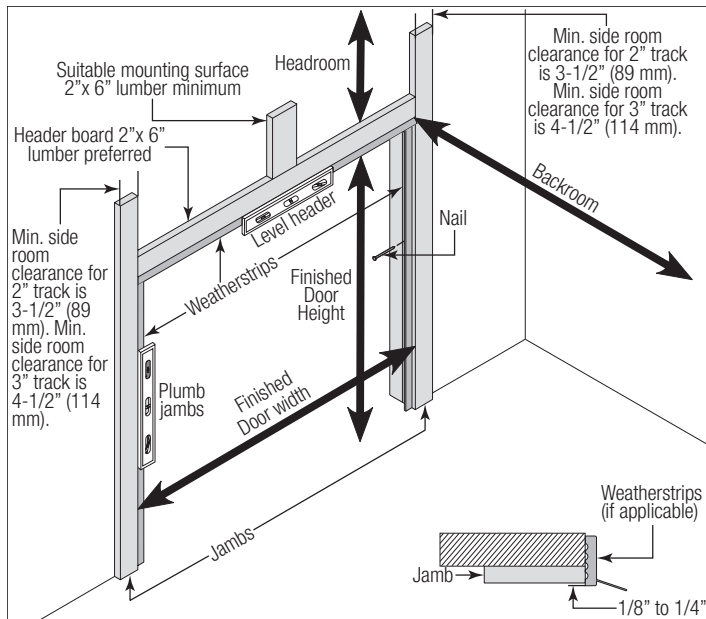

**HEADROOM REQUIREMENT:** Headroom is defined as the space needed above the top of the door for tracks, springs, etc. to allow the door to open properly. If the door is to be motor operated, 2-1/2" (64 mm) of additional headroom is required.

**DIMENSION (DIM.) "Y":** Indicates the distance from the header to the center line of torsion shaft.

**NOTE:** 2-1/2" of additional headroom is required for single trolley operator installations.

**NOTE:** Headroom can be reduced 2-1/2" by using the quick closing top fixture or by shortening the vertical tracks by 3" max.

**HEADROOM REQUIREMENTS (MINIMUM DISTANCE REQUIRED)**

Cable Drums	Dimensions	3" Track, 15" Radius	2" Track, 15" Radius	2" Track, 12" Radius
400-8	Headroom Dim. "Y"	15-1/2"	15"	12"
400-12		13"	12-1/2"	9-1/2"
5250-18		17-1/2"	17"	14"
		14-1/2"	14"	11"
800-32		21"	20-1/2"	N/A
	16-1/2"	16"	N/A	

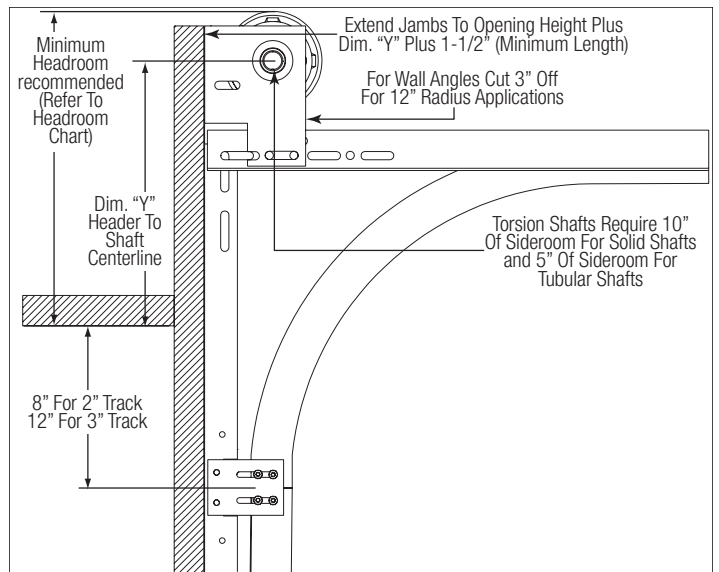

**BACKROOM REQUIREMENT:** Backroom is defined as the distance needed from the opening back into the garage to allow the door to open fully.

**BACKROOM REQUIREMENTS (MINIMUM DISTANCE REQUIRED)**

Track size	Manual Depth Into room	Dim. "A" Side room track		Dim. "B" Side room Torsion Shaft	
		Steel	Masonry / Wood	Solid	Tube
2"	Door Height Plus 18", Motor Plus 66"	2-1/2"	3-1/2"	10"	5"
3"	Door Height Plus 24", Motor Plus 66"	3"	5"	10"	5"

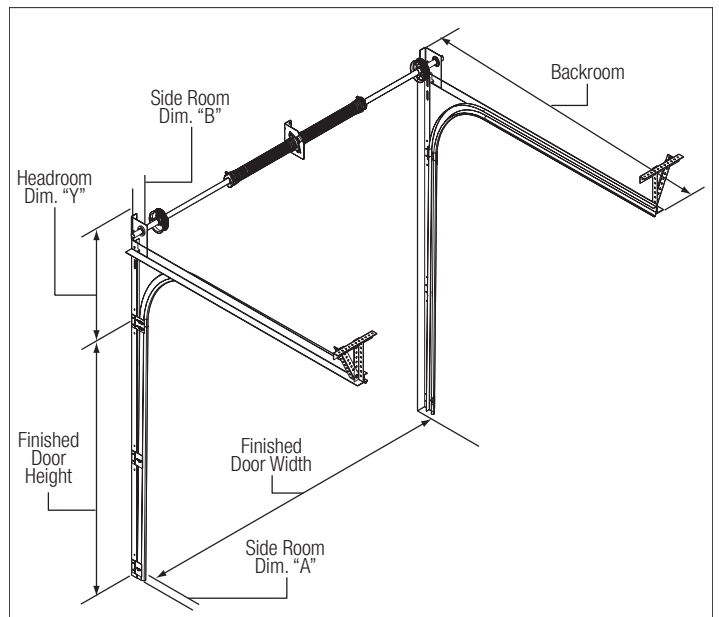

**SIDE ROOM REQUIREMENTS:** Side room is defined as the distance needed from the door opening to a wall or any obstruction.

**SIDE ROOM REQUIREMENTS (MINIMUM DISTANCE REQUIRED)**

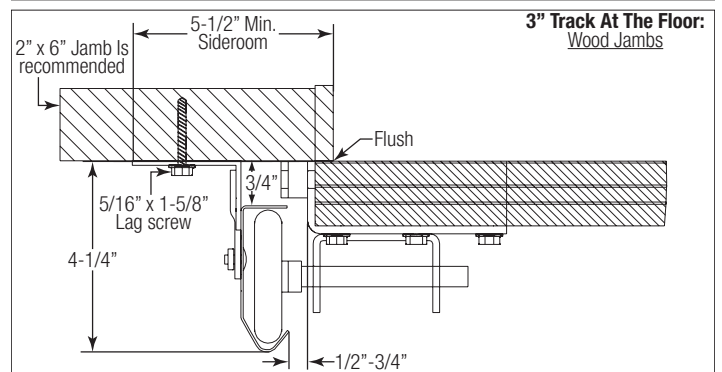
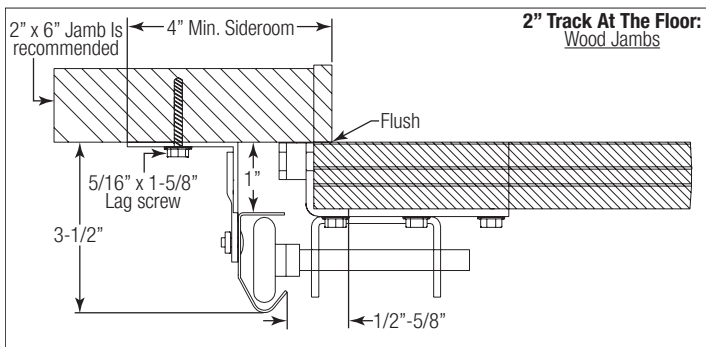
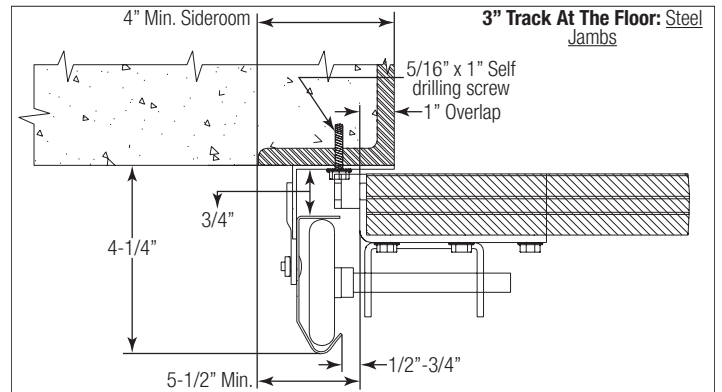
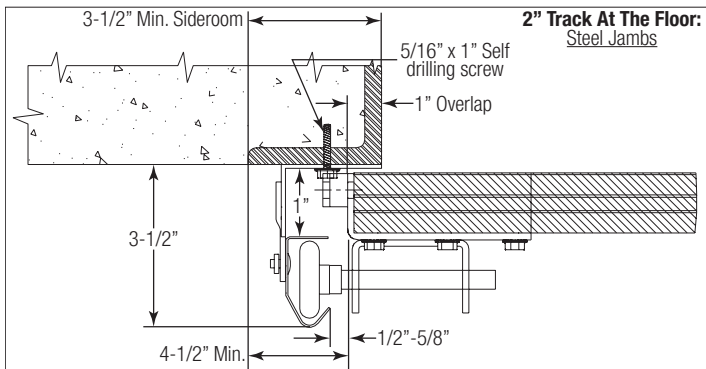
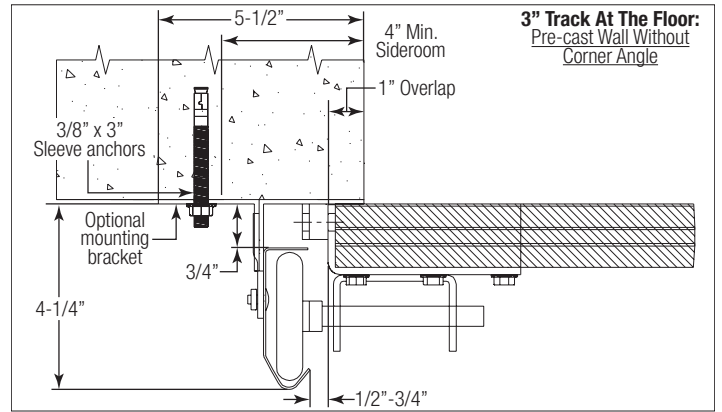
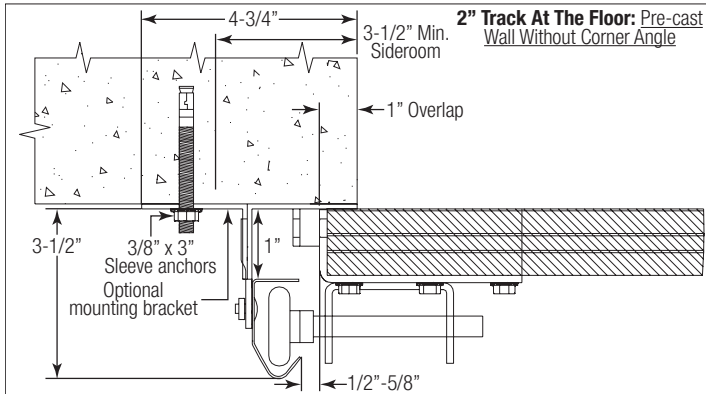
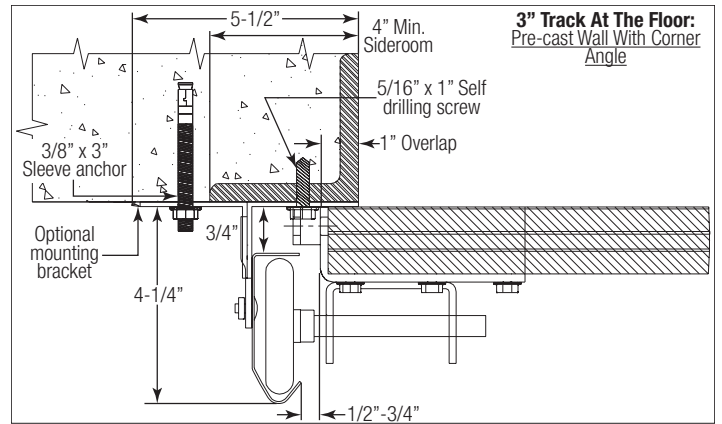
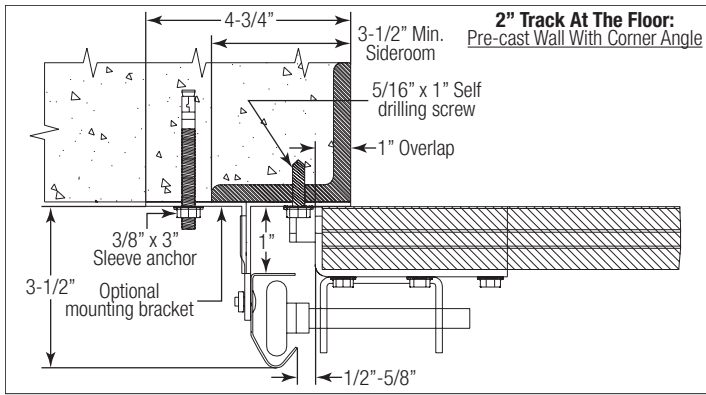

## Package Contents

**NOTE:** Depending on the door model, some parts listed will not be supplied if not required. Rear Back Hangs may not be included with your door.

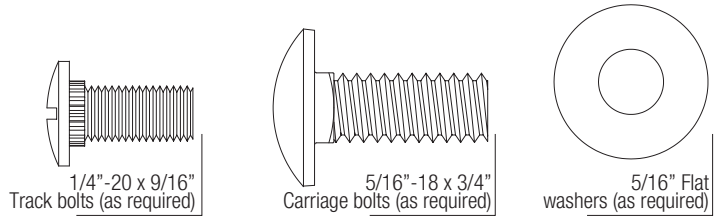
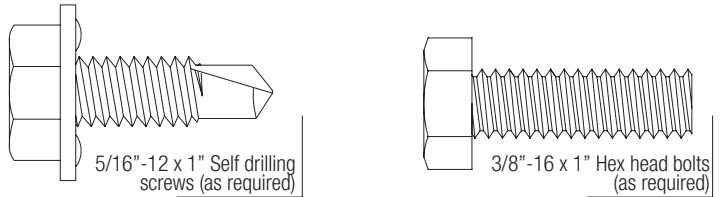
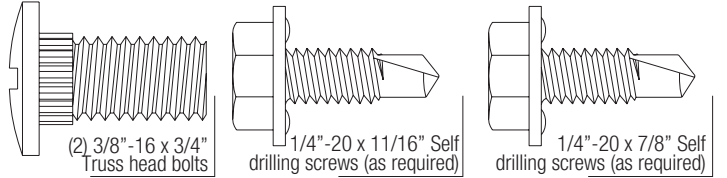
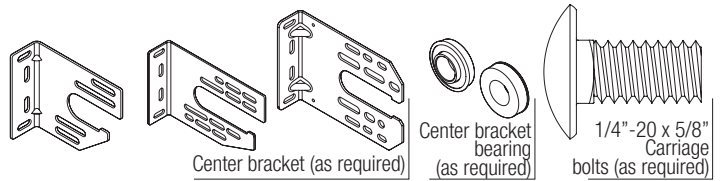
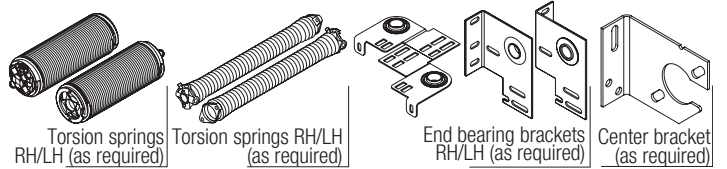
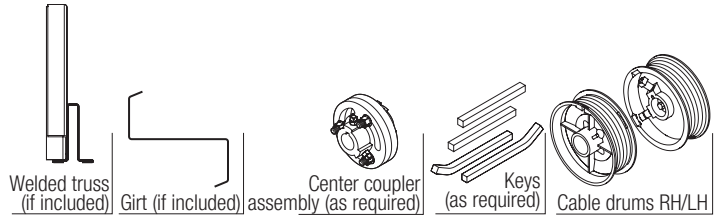
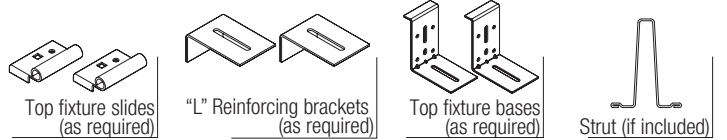
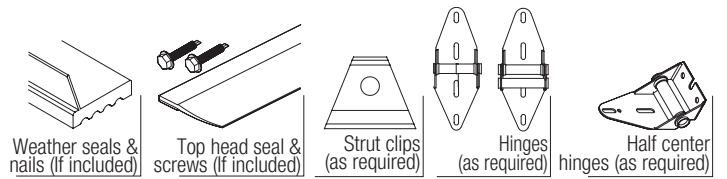
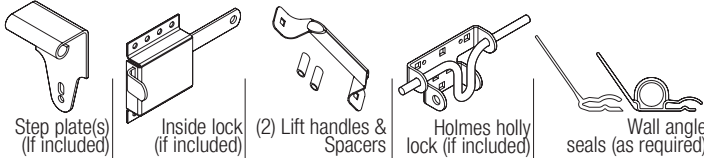
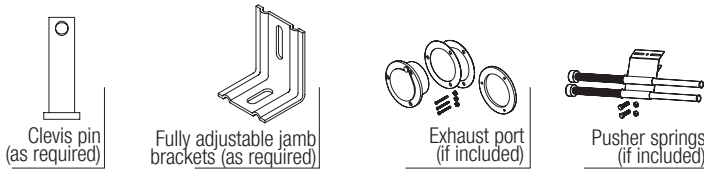
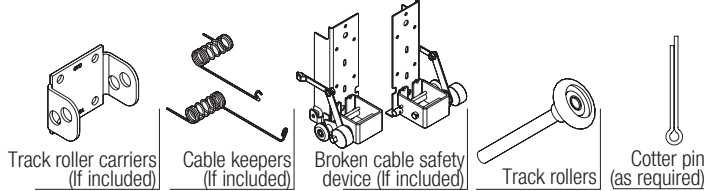
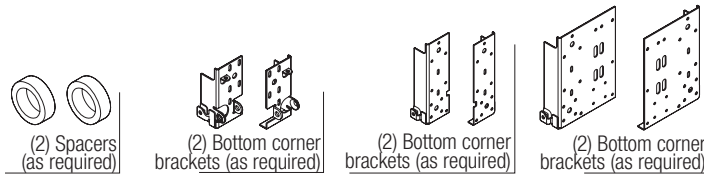
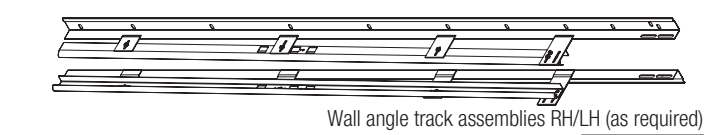
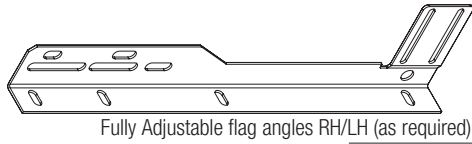
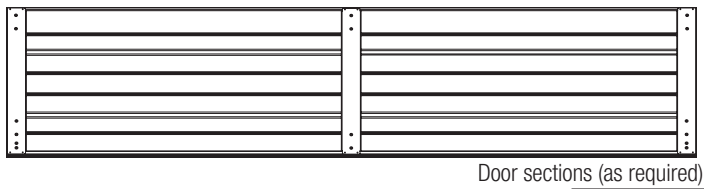

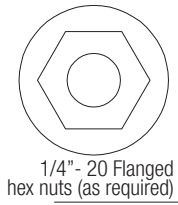

1/4" - 20 Flanged hex nuts (as required)

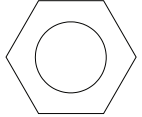

5/16" - 18 Hex nuts (as required)

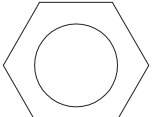

3/8" - 16 Hex nuts (as required)

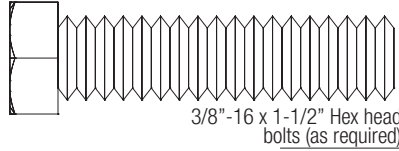

3/8" - 16 x 1-1/2" Hex head bolts (as required)

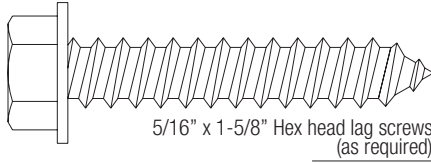

5/16" x 1-5/8" Hex head lag screws (as required)

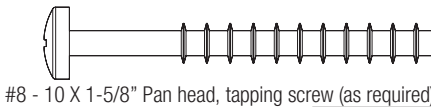

#8 - 10 X 1-5/8" Pan head, tapping screw (as required)

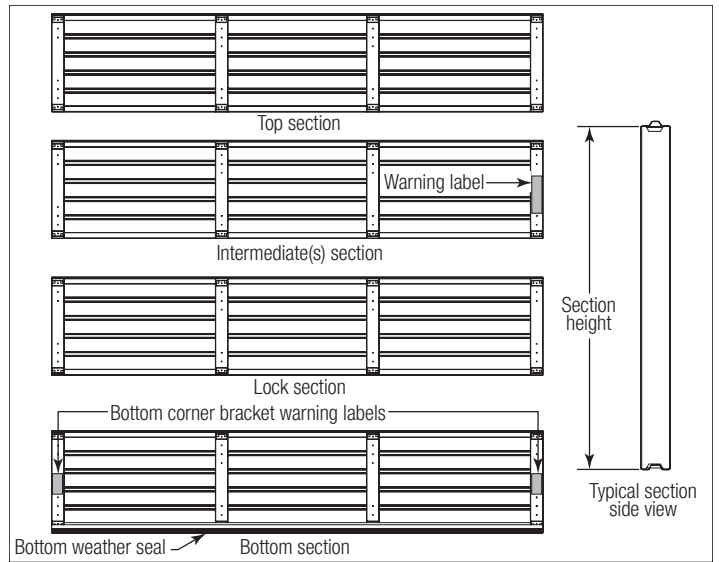

## Door Section Identification

**NOTE:** To determine your Door Section Identification, refer to the Type Of Sections chart below to determine the number of sections your door came with.

Type Of Sections	
How Many Sections High	Type Of Section
12	Top Section
11	Intermediate Section IX (As Required)
10	Intermediate Section VIII (As Required)
9	Intermediate Section VII (As Required)
8	Intermediate Section VI (As Required)
7	Intermediate Section V (As Required)
6	Intermediate Section IV (As Required)
5	Intermediate Section III (As Required)
4	Intermediate Section II (As Required)
3	Intermediate Section I (As Required)
2	Lock Section
1	Bottom Section

When installing your door you must use sections of the appropriate height in the right stacking order. What sections heights you need to use in what order depends on the height of your door Sections are either 24" or 21" in Section Height.

**NOTE:** If you have different sections heights, the 24" sections heights are always stacked at the bottom and the 21" sections height stacked to the top.

Unless your door is three sections height, you will not receive an Intermediate I section.

## Tools Required

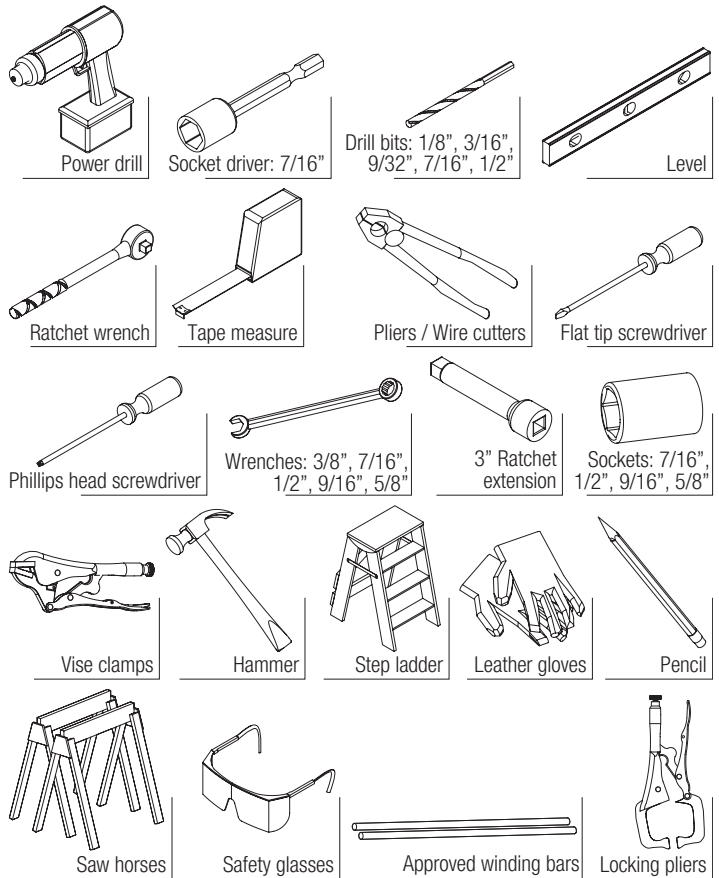

# BREAKDOWN OF PARTS

**NOTE:** The illustrations shown on this page are general representations of the door parts. Each specific door models may have unique variations.

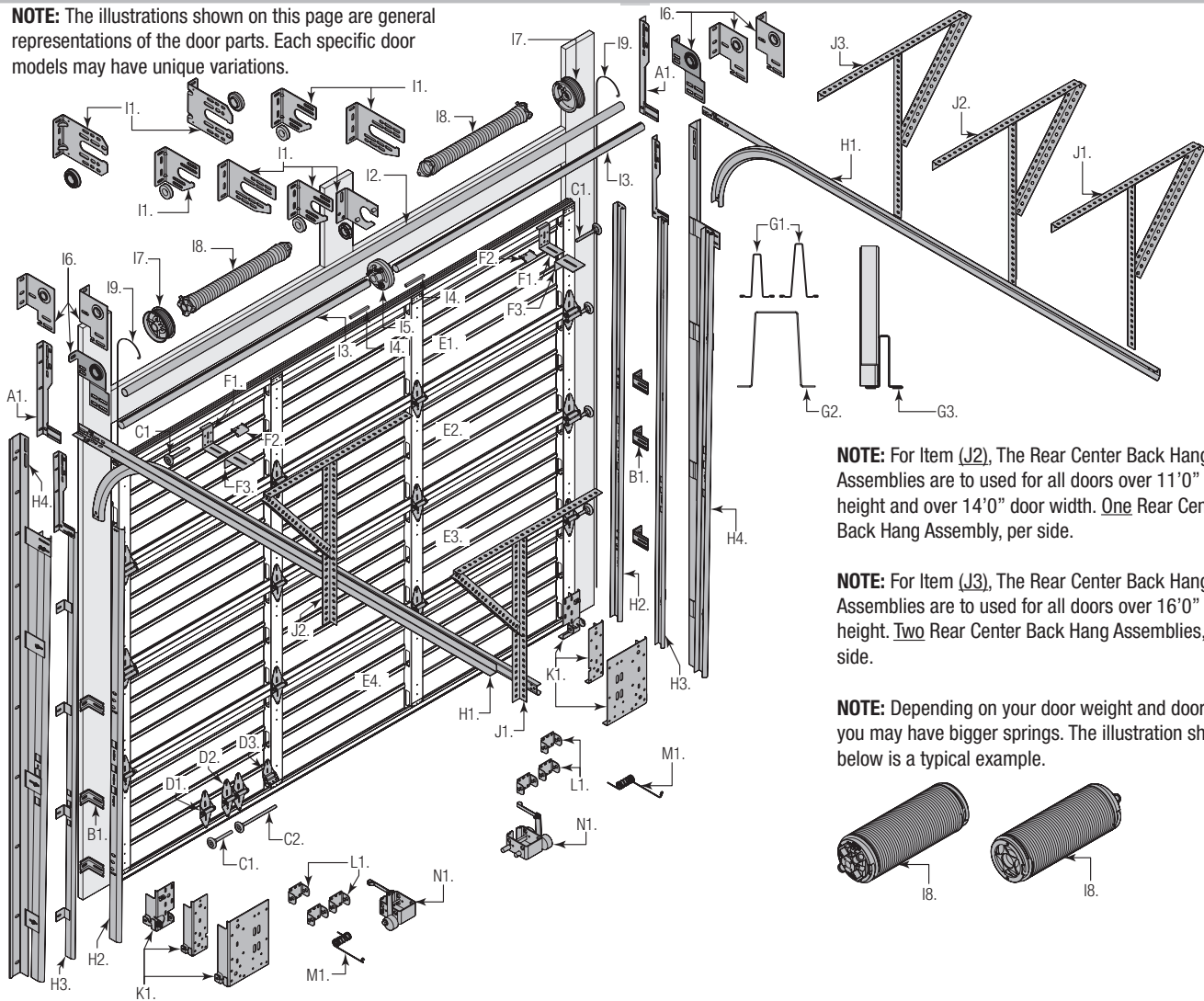

**NOTE:** For Item (J2), The Rear Center Back Hang Assemblies are to be used for all doors over 11'0" door height and over 14'0" door width. One Rear Center Back Hang Assembly, per side.

**NOTE:** For Item (J3), The Rear Center Back Hang Assemblies are to be used for all doors over 16'0" door height. Two Rear Center Back Hang Assemblies, per side.

**NOTE:** Depending on your door weight and door height, you may have bigger springs. The illustration shown below is a typical example.

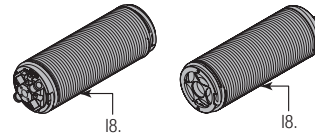

**A. FLAG ANGLES (AS REQUIRED):**

A1. Fully Adjustable (F.A.) Flag Angles

**B. JAMB BRACKETS (AS REQUIRED):**

B1. Fully Adjustable (F.A.) Jamb Brackets

**C. TRACK ROLLERS (AS REQUIRED):**

C1. Short Stem Track Rollers / C2. Long Stem Track Rollers

**D. GRADUATED END HINGES (AS REQUIRED):**

- D1. Single Graduated End Hinges (S.E.H.), Industry Standard
- D2. Double Graduated End Hinges (D.E.H.), Industry Standard
- D3. Half Center Hinges (As Required)

**E. STACKED SECTIONS:**

- E1. Top Section
- E2. Intermediate(s) Section
- E3. Lock Section
- E4. Bottom Section

**F. TOP FIXTURES (AS REQUIRED):**

- F1. Top Fixture Bases
- F2. Top Fixture Slides
- F3. "L" Reinforcing Brackets (As Required)

**G. STRUT(S) (AS REQUIRED):**

- G1. Strut (2" / 3" U-shaped)
- G2. Welded Truss / G3. Girt

**H. TRACKS (AS REQUIRED):**

H1. Left Hand and Right Hand Horizontal Track Assemblies

- H2. Left Hand and Right Hand Vertical Tracks
- H3. Left Hand and Right Hand Vertical Track Assemblies
- H4. Left Hand and Right Hand Wall Angle Track Assemblies

**I. TORSION SPRING ASSEMBLY (AS REQUIRED):**

- I1. Center Bracket(s) With Center Bracket Bearing(s) (As Required)
- I2. Torsion Shaft / Torsion Keyed Shaft (As Required)
- I3. Torsion Keyed Shafts (As Required) / I4. Keys (As Required)
- I5. Center Coupler Assembly (As Required)
- I6. Left Hand And Right Hand End Bearing Brackets
- I7. Left Hand And Right Hand Cable Drums
- I8. Left Hand and Right Hand Torsion Springs (As Required)
- I9. Counterbalance Lift Cables

**J. REAR BACK HANGS (AS REQUIRED):**

- J1. Left and Right Hand Rear Back Hangs Assemblies
- J2. Left and Right Hand Rear Center Back Hang Assemblies (As Required)
- J3. Left and Right Hand Rear Center Back Hang Assemblies (As Required)

**K. BOTTOM CORNER BRACKETS (AS REQUIRED):**

K1. Left Hand and Right Hand Bottom Corner Brackets

**L. TRACK ROLLER CARRIERS (AS REQUIRED):**

L1. Track Roller Carriers

**M. CABLE KEEPERS (AS REQUIRED):**

M1. Cable Keepers

**N. BROKEN CABLE SAFETY DEVICES (AS REQUIRED):**

N1. Left Hand And Right Hand Broken Cable Safety Devices

# DOOR INSTALLATION INSTRUCTIONS

Before installing your door, be certain that you have read and followed all of the instructions covered in the pre-installation section of this manual. Failure to do so may result in an improperly installed door.

**NOTE:** Reference TDS 160 for general garage door terminology at [www.dasma.com](http://www.dasma.com).

**IMPORTANT:** IF THE DOOR WILL BE EXPOSED TO A SIGNIFICANT AMOUNT OF ROAD SALT, PAINT THE BARE GALVANIZED BOTTOM WEATHER STEEL RETAINER TO INHIBIT RUSTING.

## 1 Attaching Flag Angles and Jamb Brackets To Vertical Tracks

**NOTE:** If you have Riveted Track or Angle Mount Track, skip this step.

**FOR DOORS WITH FULLY ADJUSTABLE TRACK:** Hand tighten the left hand flag angle to the left hand vertical track using (2) 1/4" - 20 x 9/16" track bolts and (2) 1/4" - 20 flange hex nuts.

**NOTE:** The bottom jamb bracket is always the shortest bracket, while the center jamb bracket is the next tallest. If three jamb brackets per side are included with your door, you will have received a top jamb bracket, which is the tallest.

To attach the bottom jamb bracket, locate lower hole of the hole/ slot pattern of the 1st hole set on the vertical track. Align the slot in the jamb bracket with the lower hole of the hole/ slot pattern. Hand tighten jamb bracket using (1) 1/4" - 20 x 9/16" track bolt and (1) 1/4" - 20 flange hex nut.

Place the center jamb bracket over the lower hole of the hole/ slot pattern that is centered between the bottom jamb bracket and flag angle of the 2nd hole set. Hand tighten jamb bracket using (1) 1/4" - 20 x 9/16" track bolt and (1) 1/4" - 20 flange hex nut.

If a top jamb bracket was included, hand tighten it to vertical track using the lower hole of the hole/ slot pattern in the 3rd hole set and (1) 1/4" - 20 x 9/16" track bolt and (1) 1/4" - 20 flange hex nut.

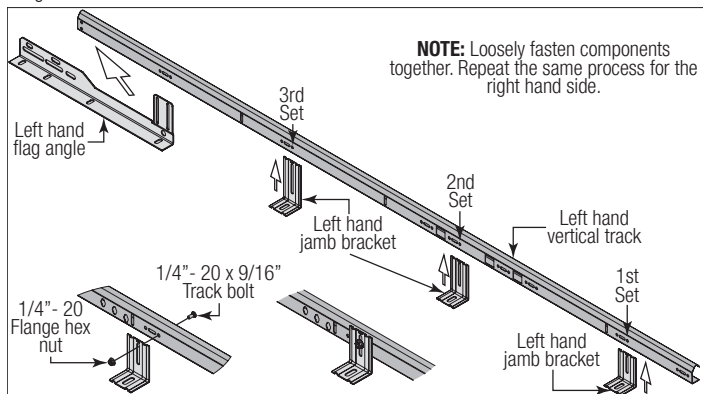

**NOTE:** Loosely fasten components together. Repeat the same process for the right hand side.

## 2 Attaching Bottom Corner Brackets

**NOTE:** Refer to door section identification, located in the pre-installation section of this manual or refer to Breakdown of Parts.

Uncoil the counterbalance lift cables.

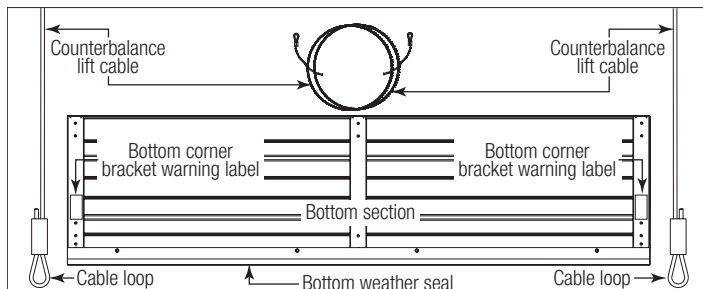

**NOTE:** Refer to Package Contents / Breakdown of Parts, to determine which bottom corner brackets you have.

Secure the cable loop to the clevis pin and bottom corner bracket using a flat washer and a cotter pin. Repeat for other bottom corner bracket.

## WARNING

**ENSURE TIGHT FIT OF CABLE LOOP OVER PIN TO PREVENT COUNTERBALANCE LIFT CABLE FROM COMING OFF THE PIN, WHICH COULD ALLOW THE DOOR TO FALL AND RESULT IN SEVERE OR FATAL INJURY.**

Starting on the left hand side, attach the left hand bottom corner bracket to the left corner of the bottom section, making sure it is seated to the edges of the end cap, using 1/4" - 20 x 7/8" self drilling screws. Insert a short stem track roller with roller spacer (if applicable) into the bottom corner bracket. Repeat for other side.

**NOTE:** If you have broken cable safety devices, install (4) 1/4" - 20 x 7/8" self drilling screws to secure the bottom corner bracket to the bottom section. Reference Step Broken Cable Safety Devices.

**NOTE:** If you did not receive Track Roller Carriers or Cable Keepers, then insert a short stem track roller with roller spacer (if applicable) into each of the bottom corner brackets, as shown.

**NOTE:** Verify bottom weather seal (bottom seal) is aligned with door section. If there is more than 1/2" excess bottom weather seal on either side, trim bottom weather seal even with door section.

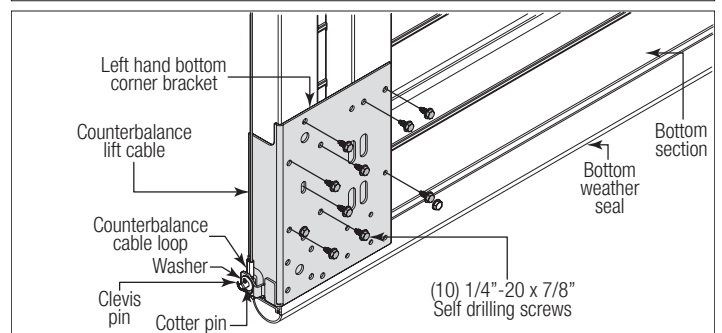
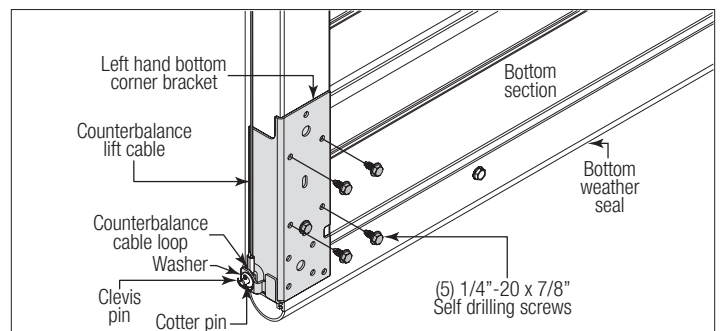
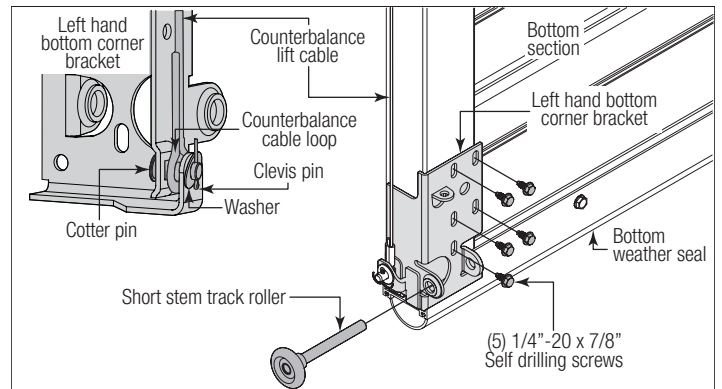

## 3 Attaching Track Roller Carrier's

**NOTE:** If you don't have track roller carriers, then skip this step. Refer to Package Contents / Breakdown of Parts, to determine if a track roller carrier was supplied with your door.

Starting on left hand side of the bottom section, attach the track roller carrier with the stamp "STD" facing UP to the bottom corner bracket by aligning the four holes of the track roller carrier with the four holes in the bottom corner bracket. Secure the track roller carrier to the bottom corner bracket using 1/4" - 20 x 7/8" self drilling screws, as shown. Repeat for the other track roller carrier and repeat the same process for the right hand side.

**NOTE:** If you did not receive cable keepers, then insert the appropriate stem track roller with roller spacer into each of the bottom corner brackets, as shown. Repeat the same process for the right hand side.



**NOTE:** The track roller carrier's inner holes are used on doors with 2" track applications with a short stem track roller; the outer holes are used on doors with 3" track applications with a long stem track roller.

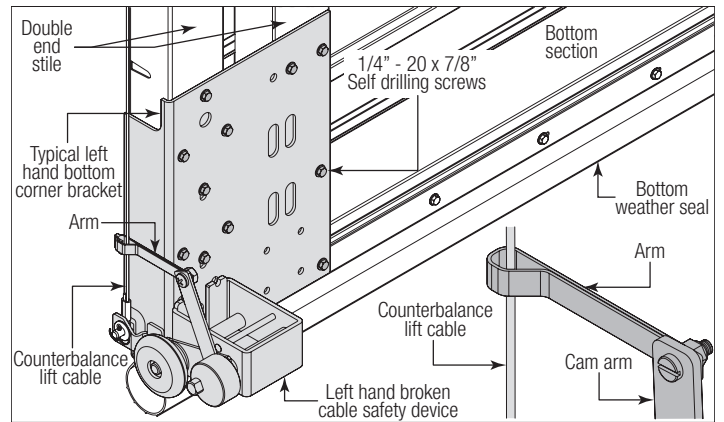
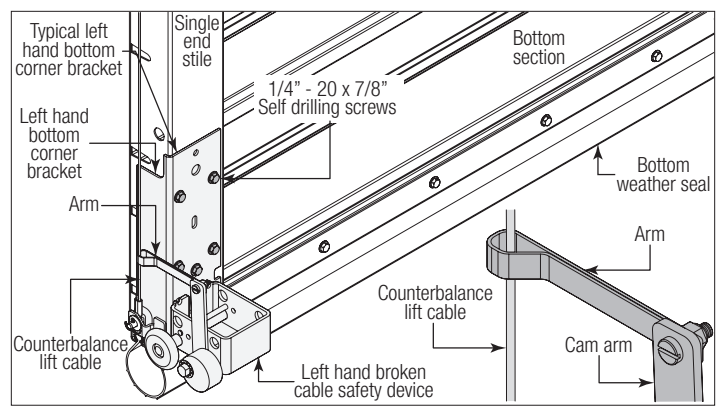
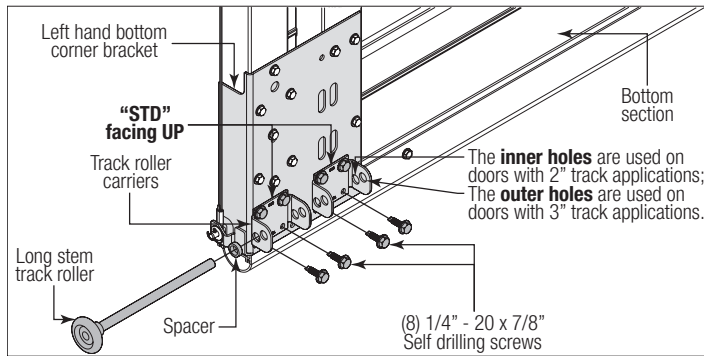
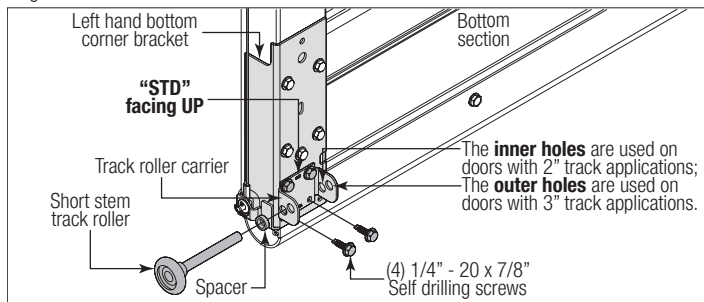

## 4 Attaching Cable Keepers

**NOTE:** If you don't have cable keepers, then skip this step. Refer to Package Contents / Breakdown of Parts, to determine if you have cable keepers.

**IMPORTANT:** CABLE KEEPERS ARE INTENDED TO HELP PREVENT COUNTERBALANCE LIFT CABLES FROM COMING OFF CABLE DRUMS ON MANUALLY OPERATED DOORS.

**NOTE:** Cable keepers are right hand and left hand.

**NOTE:** Cable keepers are color coded, black for right hand side and red for left hand side.

Locate the left hand cable keeper. Starting on the left hand side of bottom section, position the left hand cable keeper in between the roller carrier tabs. Insert a short stem track roller with roller spacer through the holes in the tabs and through the cable keeper. Repeat the same process for the right hand side.

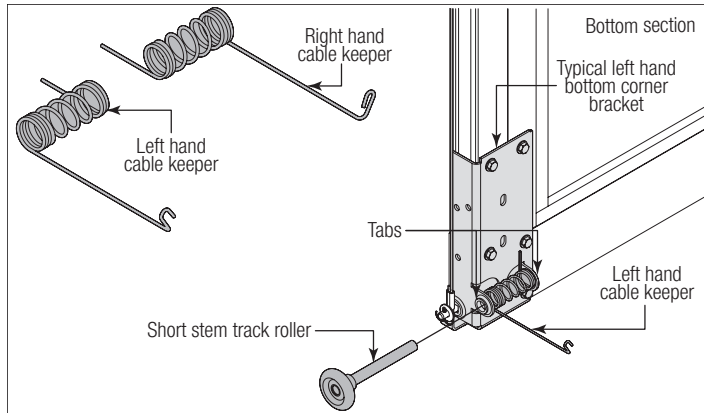

## 5 Attaching Broken Cable Safety Device

**NOTE:** If you don't have broken cable safety devices, then skip this step. Refer to Package Contents / Breakdown of Parts, to determine if you have broken cable safety devices.

Locate the left hand broken cable safety device. Reference step Bottom Corner Brackets to secure the counterbalance cable to the broken cable safety device. Next, align the broken cable safety device horizontally with the bottom edge of the bottom section and also align the broken cable safety device vertically with the left bottom edge of the bottom section. Attach the broken cable safety device to the bottom section with (6) 1/4" - 20 x 7/8" self drilling screws, as shown. Next, thread the counterbalance lift cable through the arm of the broken cable safety device. Repeat the same process for the right hand side.

## 6 Attaching Hinges

**NOTE:** Refer to door section identification, located in the pre-installation section of this manual to determine what size sections you need to use as your lock (second) section, intermediate (third) section, intermediate (fourth) section, intermediate (fifth) section, intermediate (sixth) section, intermediate (seventh) section, intermediate (eighth) section, intermediate (ninth) section and top section. Measure your sections to make sure they are the correct height as indicated on the chart.

**NOTE:** The graduated hinges can be identified by the number stamped onto their lower hinge leaf.

The graduated end hinge sequence is dependent on your track size (2" or 3"). Refer to Graduated End Hinge Schedule below.

Section Type	Graduated End Hinge Schedule		
	Graduated End Hinge Number		
	2" Track	3" Track (<= 9 Sections)	3" Track (> 9 Sections)
Intermediate IX	N/A	N/A	#8
Intermediate VIII	N/A	N/A	#7
Intermediate VII	N/A	N/A	#7
Intermediate VI	N/A	#10	#6
Intermediate V	#7	#9	#6
Intermediate IV	#6	#8	#5
Intermediate III	#5	#7	#5
Intermediate II	#4	#6	#4
Intermediate I	#3	#5	#4
Lock	#2	#4	#3
Bottom	#1	#3	#3

**IF YOU HAVE SINGLE END STILES:** Locate the bottom section and the appropriate number of graduated end hinges (Reference Graduated End Hinge Schedule chart) for the end stiles. Starting on the left hand side of the bottom section, align the lower hinge leaf of the graduated end hinge over the two punch marks, located at the top of the single end stile. Attach lower hinge leaf to the section using (2) 1/4" - 20 x 7/8" self drilling screws. Repeat the same process for the right hand side. Place a short stem track roller into each graduated end hinge.

**IF YOU HAVE DOUBLE END STILES:** Locate the bottom section and the appropriate number of graduated end hinges (Reference Graduated End Hinge Schedule chart) for the end

stiles. Starting on the left hand side of the bottom section, align the lower hinge leaf of the graduated end hinges over the punch marks, located at the top of the double end stile. Attach each lower hinge leaf to the section using (2) 1/4" - 20 x 7/8" self drilling screws. Repeat the same process for the right hand side. Place a long stem track roller into each graduated end hinges.

**TO INSTALL CENTER HINGES:** Starting at the center of the bottom section, align the lower hinge leaf of the #1 center hinge over the two punch marks, located at the top of the center stile(s). Attach lower hinge leaf to the section using (2) 1/4" - 20 x 7/8" self drilling screws. If applicable, repeat the same process for other center hinges.

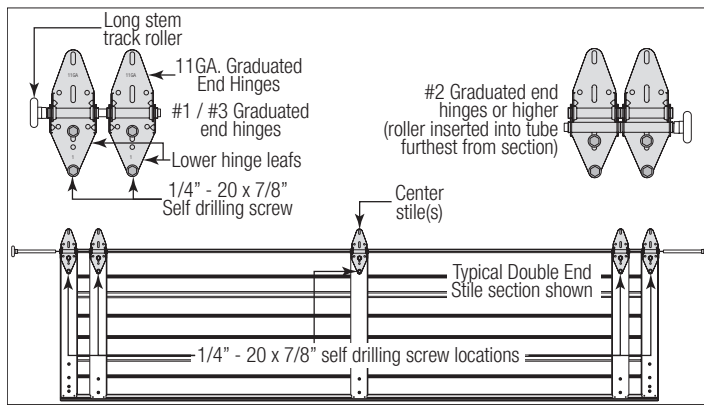
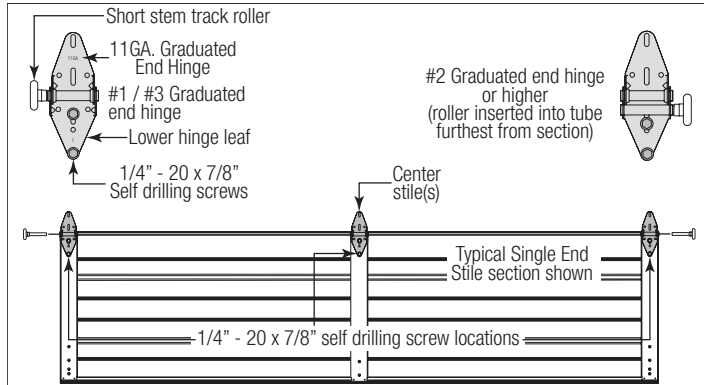

**TO INSTALL HALF CENTER HINGES ON ALUMINUM FULL VIEW SECTIONS WITH FINS:**

Position the half center hinge on top of the fin and in front of the center stile. Align the bottom (2) holes in the half center hinge over the (2) pre-punch holes in the fin. Secure the half center hinge to the fin using (2) 1/4" - 20 x 9/16" track bolts and (2) 1/4" - 20 flange hex nuts, as shown. Repeat the same process for the other half center hinges.

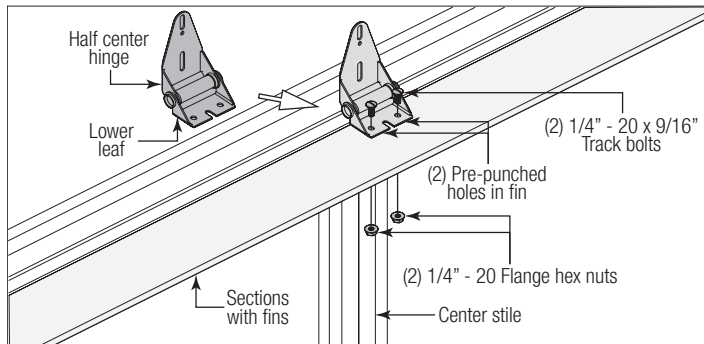

**IMPORTANT:** ONCE THE 1/4" - 20 X 7/8" SELF DRILLING SCREWS ARE SNUG AGAINST THE LOWER HINGE LEAFS, TIGHTEN AN ADDITIONAL 1/4 TO 1/2 TURN TO RECEIVE MAXIMUM DESIGN HOLDING POWER.

**IMPORTANT:** PUSH & HOLD THE HINGE LEAF SECURELY AGAINST THE SECTION WHILE SECURING WITH 1/4" - 20 X 7/8" SELF DRILLING SCREWS. THERE SHOULD BE NO GAP BETWEEN THE HINGE LEAF AND THE SECTION.

Repeat graduated end hinge / center hinge / half center hinge attachment using the appropriate graduated end hinges for all remaining sections, except for the top section.

**IMPORTANT:** WHEN PLACING TRACK ROLLERS INTO THE #2 GRADUATED END HINGES AND HIGHER, THE TRACK ROLLER GOES INTO HINGE TUBE FURTHEST AWAY FROM SECTION.

## 7 Attaching Top Head Seal

**NOTE:** If you don't have a top head seal, then skip this step. Refer to Package Contents / Breakdown of Parts, to determine if you have a top head seal.

**NOTE:** Refer to door section identification, located in the pre-installation section of this

manual. Refer to Package Contents / Breakdown of Parts, to determine your top section.

Cut the top head seal (if needed) to the width of the top section. Remove the protective strip from the adhesive tape on the top head seal. Install the top head seal onto the top outer edge (flat) of the top section.

**CAUTION**  
VERIFY TOP HEAD SEAL IS ALIGNED WITH THE FLAT PORTION OF THE TOP SECTION, PRIOR TO FASTENING.

Secure the top head seal to the top section using #8 - 18 x 3/4" self-drilling screws, placing one 6" in from each end of the top section and one every 18" (maximum) in between, as shown.

**NOTE:** Install screws into the flat portion of the top head seal.

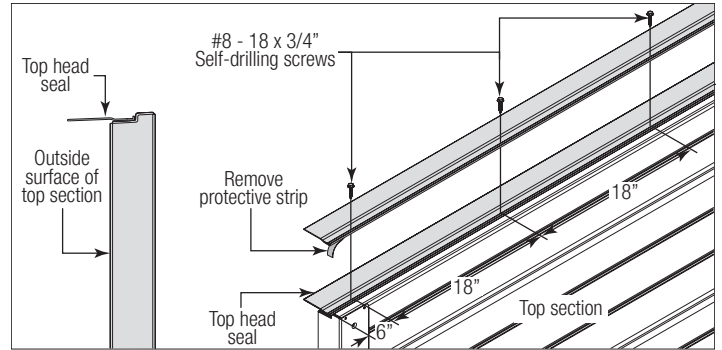

## 8 Attaching Top Fixtures / Strutting

**NOTE:** Refer to Door Section Identification / Breakdown of Parts to determine how many top fixtures you have.

**NOTE:** If your door came with two top fixtures, then one top fixture and a short stem track roller are required for each side.

**NOTE:** If your door came with four top fixtures, then two top fixtures and a long stem track roller are required for each side.

Loosely secure the top fixture slide and the "L" reinforcement bracket (if applicable) to the top fixture base using (1) 5/16" - 18 x 3/4" carriage bolt and (1) 5/16" - 18 hex nut, as shown. Repeat for other top fixture assemblies.

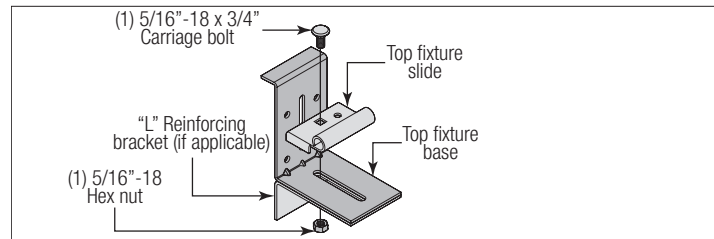

**NOTE:** The top section only receives a strut (if applicable) and does not require graduated end hinges and center hinges to be installed onto the section.

Starting on the left hand side of the top section, position the top fixture base on top of the top section, as shown. If your top section does not require a strut (reference strutting schedules below), then secure the top fixture(s) to the section using (2) 1/4" - 20 x 7/8" self drilling screws. If your top section does require a strut, then position the strut on top of the top fixtures, as shown. Center the strut side to side on the section. Secure the strut and top fixtures to the section using (2) 1/4" - 20 x 7/8" self drilling screws for each top fixture and (2) 1/4" - 20 x 7/8" self drilling screws at each center stile location. Next, secure the "L" reinforcement bracket (if applicable) to the top section using (1) 1/4" - 20 x 7/8" self drilling screw. Repeat the same process for other top fixture assembly(s). Insert the appropriate short / long stem track roller into top fixture slide(s). The top fixture assembly will be tightened and adjusted later, in step, Adjusting Top Fixtures.

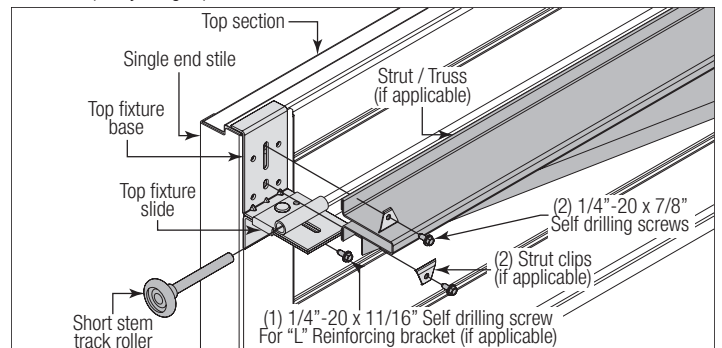

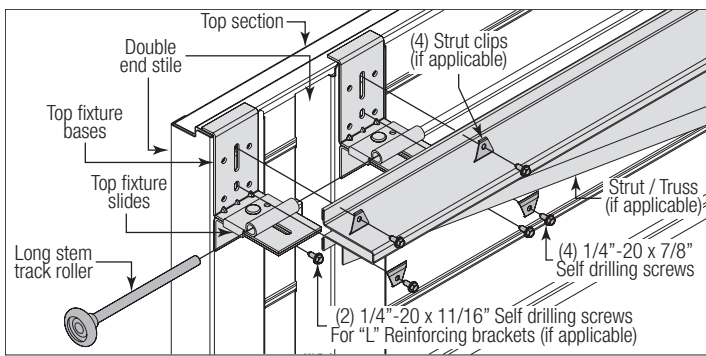

**NOTE:** If your door is to be trolley operated, it is recommended that a strut be installed along the top rail.

**NOTE:** Refer to the strutting schedules below to determine the placement of strut(s) on your door. Be sure to use the proper schedules for the type of door model and the size of your door.

**IMPORTANT:** WHEN REFERRING TO THE STRUTTING SCHEDULES, DETERMINE HOW MANY STRUTS YOUR DOOR NEEDS AND ON WHAT SECTIONS THEY ARE NEEDED TO BE INSTALLED.

**NOTE:** Sections not noted in the strutting schedule, do not require a strut. All strut(s) are placed at the top of the section(s) and/or under the graduated end / center hinges.

**STRUT INSTALLATION ON ALL SECTIONS (EXCEPT TOP SECTION):** Place the strut on the appropriate section up against the bottom of the hinges. Center the strut side to side on the section surface, as shown. Secure the strut to the section using (2) 1/4" - 20 x 7/8" self drilling screws at each end hinge location and (2) 1/4" - 20 x 7/8" self drilling screws at each center hinge location.

**NOTE:** If your Intermediate Section has windows in it and a strut needs to be installed on that section, strut clips will need to be used to attach it to the section.

**IMPORTANT:** ONCE THE 1/4" - 20 X 7/8" SELF DRILLING SCREWS ARE SNUG AGAINST THE LOWER HINGE LEAF, TIGHTEN AN ADDITIONAL 1/4 TO 1/2 TURN TO RECEIVE MAXIMUM DESIGN HOLDING POWER.

Repeat the same process for all remaining sections, except the top section.

Models C2400, C2400E Strutting, Door Width <= 20'2"		
Door Width	Door Height	Number Of Struts
<= 15'11"	<= 16'1"	N/A
16'0" - 16'2"	>= 6'4" to <= 10'1"	(3) 2"
	>= 10'3" to <= 14'1"	(4) 2"
	>= 14'2" to <= 16'1"	(5) 2"
16'3" - 18'2"	>= 6'4" to <= 8'1"	(4) 2"
	>= 8'3" to <= 11'6"	(5) 2"
	>= 11'9" to <= 12'1"	(6) 2"
	>= 12'3" to <= 14'1"	(7) 2"
	>= 14'2" to <= 16'1"	(8) 2"
18'3" - 20'2"	>= 6'4" to <= 8'1"	(3) 3"
	>= 8'3" to <= 11'6"	(4) 3"
	>= 11'9" to <= 14'1"	(5) 3"
	>= 14'2" to <= 16'1"	(6) 3"

Model C24 Strutting, Door Width <= 24'2"		
Door Width	Door Height	Number Of Struts
<= 15'11"	<= 24'1"	N/A
16'0" - 16'2"	>= 6'4" to <= 9'6"	(2) 2"
	>= 9'9" to <= 12'1"	(3) 2"
	>= 12'3" to <= 16'1"	(4) 3"
	>= 16'3" to <= 18'1"	(5) 3"
	>= 18'3" to <= 20'1"	(6) 3"
	>= 20'3" to <= 22'1"	(7) 3"
	>= 22'3" to <= 24'1"	(8) 2"

Model C24 Strutting, Door Width <= 24'2"		
Door Width	Door Height	Number Of Struts
16'3" - 18'2"	>= 6'4" to <= 10'1"	(4) 2"
	>= 10'3" to <= 12'6"	(5) 2"
	>= 12'3" to <= 14'1"	(6) 2"
	>= 14'3" to <= 18'1"	(7) 2"
	>= 18'3" to <= 20'1"	(8) 2"
	>= 20'3" to <= 22'1"	(9) 2"
	>= 22'3" to <= 24'1"	(10) 2"
18'3" - 20'2"	>= 6'4" to <= 9'1"	(3) 3"
	>= 9'3" to <= 12'1"	(4) 3"
	>= 12'3" to <= 16'1"	(5) 3"
	>= 16'3" to <= 18'1"	(6) 3"
	>= 18'3" to <= 20'1"	(7) 3"
	>= 20'3" to <= 22'1"	(8) 3"
18'3" - 20'2"	>= 22'3" to <= 24'1"	(9) 3"
	>= 6'4" to <= 8'1"	(4) 3"
	>= 8'3" to <= 10'1"	(5) 3"
	>= 10'3" to <= 12'1"	(6) 3"
	>= 12'3" to <= 14'1"	(7) 3"
	>= 14'3" to <= 16'1"	(8) 3"
	>= 16'3" to <= 18'1"	(9) 3"
	>= 18'3" to <= 20'1"	(10) 3"
	>= 20'3" to <= 22'1"	(11) 3"
>= 22'3" to <= 24'1"	(12) 3"	
20'3" - 22'2"	>= 6'4" to <= 8'1"	(4) 3"
	>= 8'3" to <= 10'1"	(5) 3"
	>= 10'3" to <= 12'1"	(6) 3"
	>= 12'3" to <= 14'1"	(7) 3"
	>= 14'3" to <= 16'1"	(8) 3"
	>= 16'3" to <= 18'1"	(9) 3"
	>= 18'3" to <= 20'1"	(10) 3"
	>= 20'3" to <= 22'1"	(11) 3"
	>= 22'3" to <= 24'1"	(12) 3"
22'3" - 24'2"	>= 6'4" to <= 8'1"	(6) 3"
	>= 8'3" to <= 9'1"	(7) 3"
	>= 9'3" to <= 11'1"	(8) 3"
	>= 11'3" to <= 12'1"	(9) 3"
	>= 12'3" to <= 14'1"	(10) 3"
	>= 14'3" to <= 16'1"	(12) 3"
	>= 16'3" to <= 18'1"	(13) 3"
	>= 18'3" to <= 20'1"	(14) 3"
	>= 20'3" to <= 22'1"	(15) 3"
	>= 22'3" to <= 24'1"	(16) 3"

Model C20 Strutting, Door Width <= 24'2"		
Door Width	Door Height	Number Of Struts
<= 15'11"	<= 24'1"	N/A
16'0" - 16'2"	>= 6'4" to <= 12'1"	(2) 2"
	>= 12'3" to <= 18'1"	(3) 2"
	>= 18'3" to <= 20'1"	(4) 2"
	>= 20'3" to <= 22'1"	(5) 2"
	>= 22'3" to <= 24'1"	(6) 2"

**Model C20 Strutting, Door Width <= 24'2"**

Door Width	Door Height	Number Of Struts
16'3" - 18'2"	>= 6'4" to <= 11'1"	(3) 2"
	>= 11'6" to <= 14'1"	(4) 2"
	>= 14'3" to <= 18'1"	(5) 2"
	>= 18'3" to <= 20'1"	(7) 2"
	>= 20'3" to <= 22'1"	(8) 2"
	>= 22'3" to <= 24'1"	(9) 2"
18'3" - 20'2"	>= 6'4" to <= 11'3"	(3) 3"
	>= 11'6" to <= 14'1"	(4) 3"
	>= 14'3" to <= 18'1"	(5) 3"
	>= 18'3" to <= 20'1"	(6) 3"
	>= 20'3" to <= 22'1"	(7) 3"
	>= 22'3" to <= 24'1"	(8) 3"
20'3" - 22'2"	>= 6'4" to <= 10'1"	(4) 3"
	>= 10'3" to <= 12'1"	(5) 3"
	>= 12'3" to <= 14'1"	(6) 3"
	>= 14'3" to <= 18'1"	(7) 3"
	>= 18'3" to <= 20'1"	(9) 3"
	>= 20'3" to <= 22'1"	(10) 3"
	>= 22'3" to <= 24'1"	(11) 3"
	>= 22'3" to <= 24'1"	(11) 3"
22'3" - 24'2"	>= 6'4" to <= 8'1"	(5) 3"
	>= 8'3" to <= 10'1"	(6) 3"
	>= 10'3" to <= 12'1"	(7) 3"
	>= 12'3" to <= 14'1"	(8) 3"
	>= 14'3" to <= 16'1"	(10) 3"
	>= 16'3" to <= 18'1"	(11) 3"
	>= 18'3" to <= 20'1"	(12) 3"
	>= 20'3" to <= 22'1"	(13) 3"
	>= 22'3" to <= 24'1"	(14) 3"

Locate the center most center stile on the bottom section of the door. On the inside of the door and using the pre-punched holes at the bottom of the center stile as a template, drill (2) 7/32" dia. holes through the section. Using the previously drilled holes as a guide, enlarge the holes from outside the door to 7/16" dia. and assemble the outside and inside step plates to the section using (2) #8 x 1-5/8" screws.

**CAUTION**

DO NOT DRILL THROUGH OR ENLARGE HOLES ON THE INSIDE OF THE DOOR SECTION.

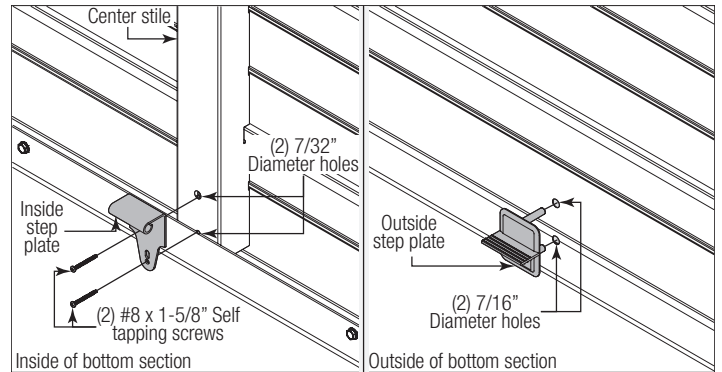

**10**

**Positioning Bottom Section**

Center the bottom section in the door opening. Level the section using wooden shims (if necessary) under the bottom section. When the bottom section is leveled, temporarily hold it in place by driving a nail into the jamb and bending it over the edge of the bottom section on both sides.

**NOTE:** For wider size doors, more than two wooden shims (shown in illustration) might be needed to level the bottom section.

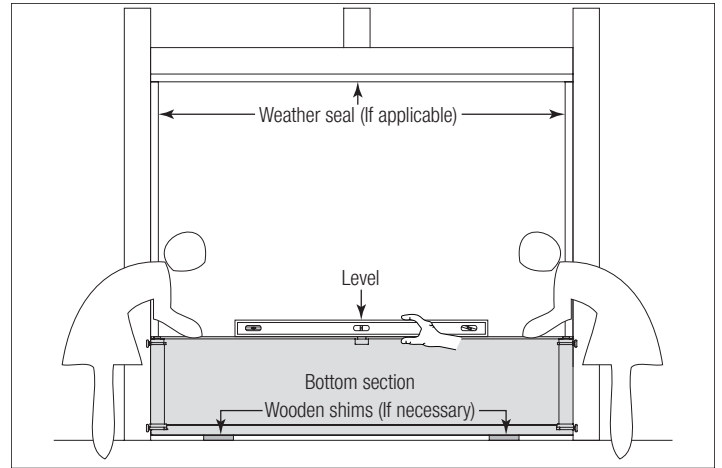

**11**

**Attaching Wall Angle Seals**

**NOTE:** If you don't have wall angle seals, then skip this step. Refer to Package Contents and or illustrations below, to determine which wall angle seals you have received.

Starting with the left hand wall angle, align the profile of the wall angle seal with the inside edge of wall angle. Next, slide wall angle seal over the inside edge of wall angle until seal is flush up against the edge of wall angle, as shown. Repeat the same process for the right hand side wall angle.

**9**

**Step Plate**

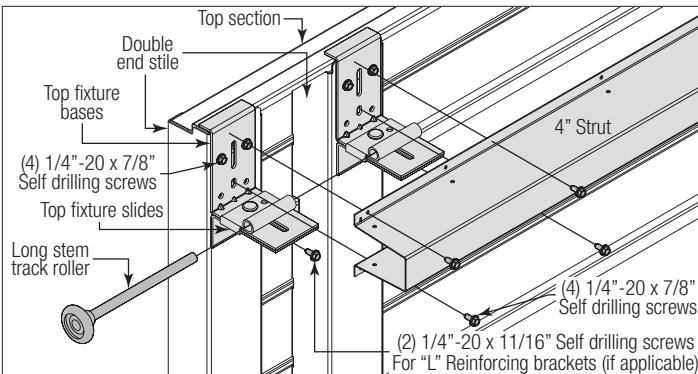
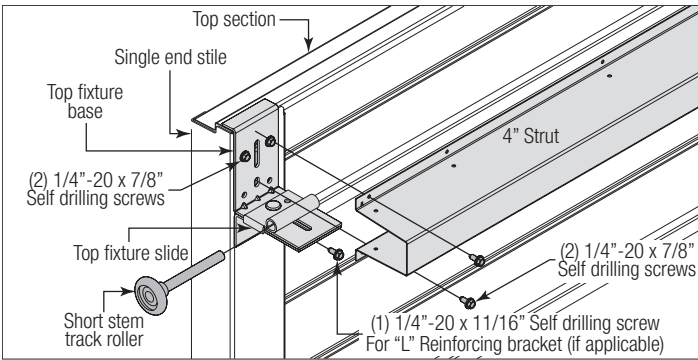

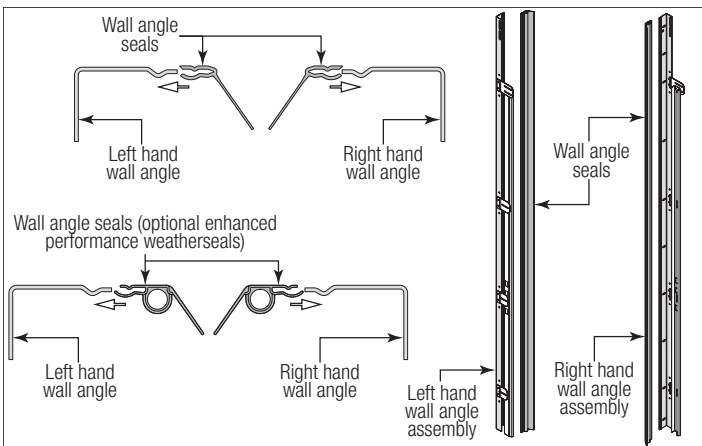

## 12 Attaching Vertical Tracks To Jamb

**NOTE:** Depending on your door, you may have Fully Adjustable Flag Angles, Riveted Vertical Track Assemblies or you may have Angle Mount Vertical Track Assemblies. Refer to Package Contents / Breakdown of Parts, to determine which Flag Angles / Vertical Track Assemblies you have.

**IMPORTANT:** IF YOUR DOOR IS TO BE INSTALLED PRIOR TO A FINISHING CONSTRUCTION OF THE BUILDING'S FLOOR, THE VERTICAL TRACKS AND THE DOOR BOTTOM SECTION ASSEMBLY SHOULD BE INSTALLED SUCH THAT WHEN THE FLOOR IS CONSTRUCTED, NO DOOR OR TRACK PARTS ARE TRAPPED IN THE FLOOR CONSTRUCTION.

**IMPORTANT:** THE TOPS OF THE VERTICAL TRACKS MUST BE LEVEL FROM SIDE TO SIDE. IF THE BOTTOM SECTION WAS SHIMMED TO LEVEL IT, THE VERTICAL TRACK ON THE SHIMMED SIDE MUST BE RAISED THE HEIGHT OF THE SHIM.

**NOTE:** Make sure the counterbalance lift cable is located between the track rollers and the door jamb.

Starting on the left hand side of the bottom section, remove the nail. Position the left hand vertical track assembly over the track rollers of the bottom section and install, as shown. Drill 3/16" pilot holes into the door jamb for the lag screws.

**LOOSELY FASTEN WALL ANGLES TO ONE OF THE FOLLOWING SCENARIOS LISTED BELOW:**

Wood jombs, using 5/16" x 1-5/8" lag screws. Drill 3/16" pilot holes into the wood jamb for the lag screws.

Steel jombs, using 5/16" x 1" self drilling screws.

Pre-cast concrete, using 3/8" x 3" sleeve anchor (not supplied).

**NOTE:** Products being installed to pre-cast or block must use a 3/8" x 3" sleeve anchor to attach the wall angle to the building, as shown. Use the slots in the wall angle as a drill template and drill a 3/8" hole (3-1/2" deep) and secure to anchor.

### ⚠ WARNING

**DO NOT USE SLEEVE ANCHORS ON HOLLOW BLOCK.**

**FOR 2" TRACK:** Tighten fasteners, securing the bottom jamb bracket in the vertical track assemblies / bottom slot in the wall angle to jamb, maintain 3/8" to 5/8" spacing, between the bottom section and vertical track.

**FOR 3" TRACK:** Tighten fasteners, securing the bottom jamb bracket in the vertical track assemblies / bottom slot in the wall angle to jamb, maintain 1/2" to 3/4" spacing, between the bottom section and vertical track.

Allow proper clearance as shown and use the values as illustrated in the Side Room Requirements (Minimum Distance Required), located in the pre-installation section of this manual.

Hang counterbalance lift cable over flag angle / angle mount. Repeat same process for other side.

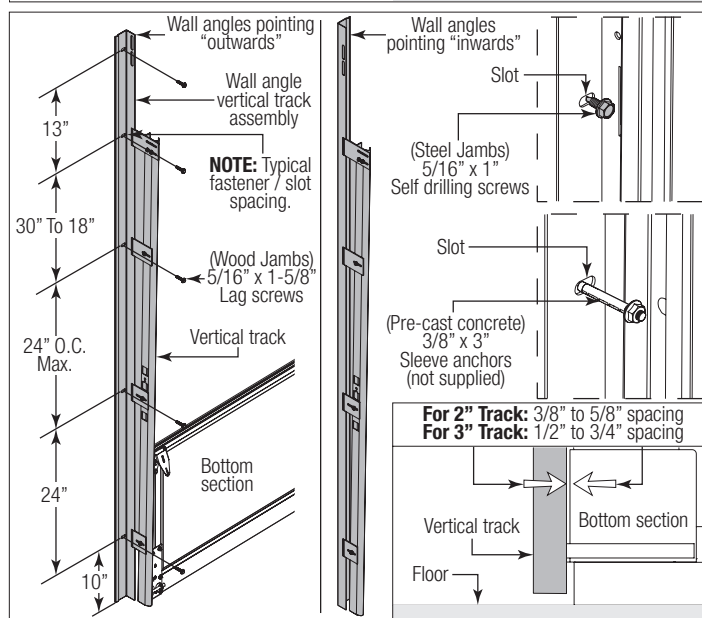
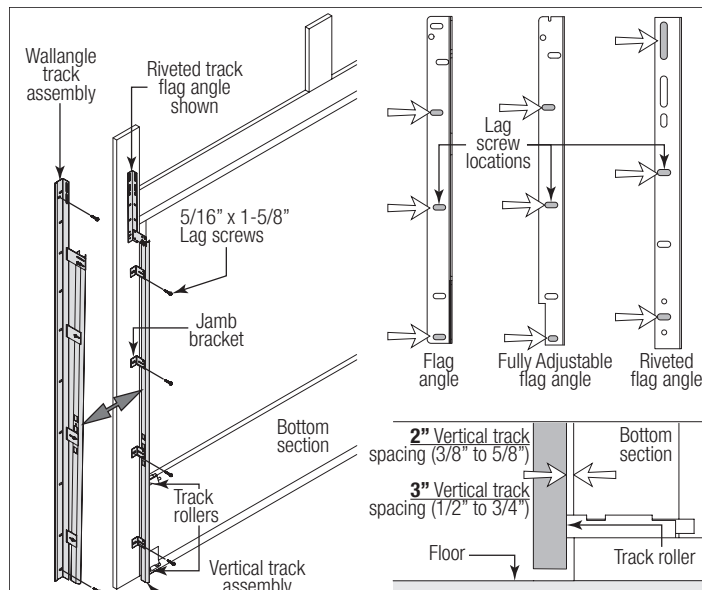

## 13 Stacking Sections

**NOTE:** Refer to door section identification, located in the pre-installation section of this manual.

**NOTE:** The sections can be identified by the installed graduated end hinges. The smallest graduated end hinge on section should be stacked on top of the bottom section, with each end hinge increasing as the sections are stacked, see Breakdown of Parts.

**NOTE:** Make sure graduated end and center hinges are flipped down, when stacking another section on top.

With assistance, lift second section and guide the track rollers into the vertical tracks. Lower section until it is seated against bottom section. Flip hinges up. Fasten center hinge(s) first; then end hinges last using 1/4" - 20 x 7/8" self drilling screws.

Repeat same process for other sections, except top section.

**IMPORTANT:** PUSH & HOLD THE HINGE LEAFS SECURELY AGAINST THE SECTIONS WHILE SECURING WITH 1/4" - 20 X 7/8" SELF DRILLING SCREWS. THERE SHOULD BE NO GAP BETWEEN THE HINGE LEAFS AND THE SECTIONS.

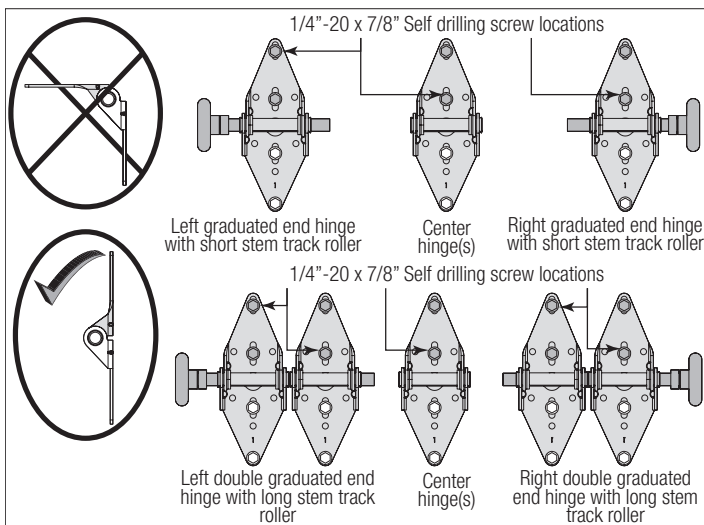
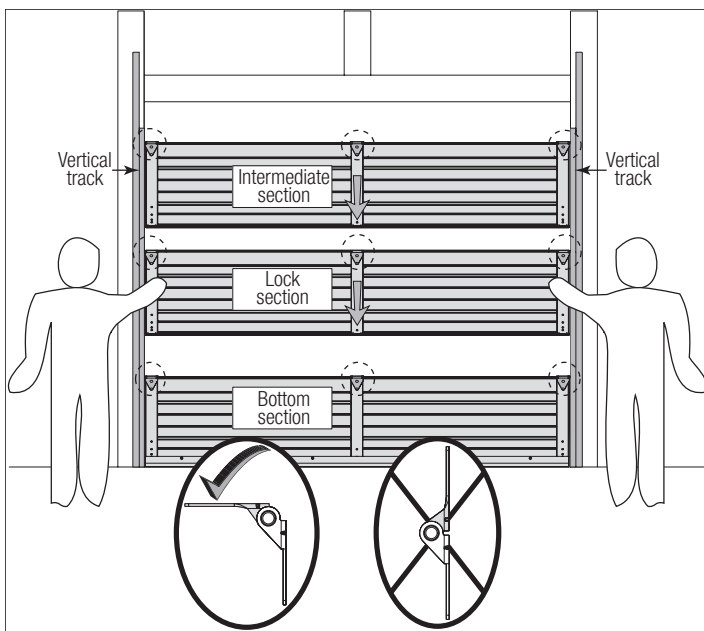

## 14 Lift Handle

**NOTE:** Doors with a Keyed lock do not require this lift handle.

Locate the inside center stile or the desired lift handle location on the lock (2nd) section of the door. Position the lower hole in the lift handle 4" from the bottom of the lock (2nd) section.

**IMPORTANT:** THE DISTANCE BETWEEN THE STEP PLATE AND THE MIDDLE OF THE LIFT HANDLE MUST BE 20" MINIMUM TO 30" MAXIMUM. IF NECESSARY REPOSITION THE UPPER LIFT HANDLE TO STAY WITHIN THE REQUIRED DIMENSION.

Using the lift handle holes as a template, drill (2) 9/32" dia. holes through the lock section. Enlarge the holes from the outside the door to 1/2" dia.

### CAUTION

DO NOT DRILL THROUGH OR ENLARGE HOLES ON THE INSIDE OF THE DOOR SECTION.

Assemble the outside and inside lift handles to the lock section using (2) spacers, (2) 1/4" - 20 x 2-1/2" carriage bolts and (2) 1/4" - 20 hex nuts.

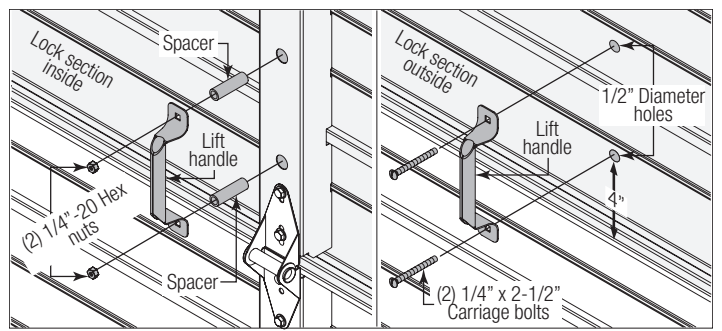

## 15 Stacking Top Section

Place the top section in the opening. Install a nail to prevent the top section from falling backwards. Now, flip up the hinge leaves, hold tight against section, and fasten center hinges first and end hinges last (refer to step, Stacking Sections). Vertical track alignment is critical.

**POSITION FLAG ANGLE OR ANGLE MOUNT FROM THE EDGE OF THE DOOR:**

**FOR 2" TRACK APPLICATIONS:** 1-11/16" (43 mm) to 1-3/4" (44 mm) for smooth, safe door operation.

**FOR 3" TRACK APPLICATIONS:** 2-3/16" (56 mm) to 2-1/4" (57 mm) for smooth, safe door operation

Tighten the bottom lag screw. Flag angles / Angle mount must be parallel to the door sections. Repeat for other side.

**FOR 2" TRACK APPLICATIONS:** Door width plus 3-3/8" (86mm) to 3-1/2" (89 mm) for smooth, safe door operation.

**FOR 3" TRACK APPLICATIONS:** Door width plus 4-7/8" (124mm) to 5" (127 mm) for smooth, safe door operation.

Complete the vertical track installation by securing the fasteners to the jamb. Push the vertical track against the track rollers so that the track rollers are touching the deepest part of the curved side of the track; tighten all the track bolts and nuts. Repeat for other side.

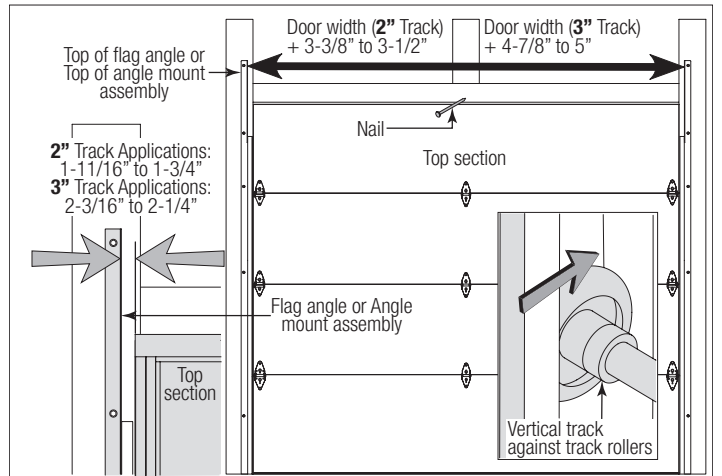

## 16 Attaching Horizontal Tracks

**NOTE:** Depending on your door, you may have Fully Adjustable Flag Angles, Riveted Vertical Track Assemblies or you may have Angle Mount Vertical Track Assemblies. Refer to Package Contents / Breakdown of Parts, to determine which Flag Angles / Vertical Track Assemblies you have.

### WARNING

DO NOT RAISE DOOR UNTIL HORIZONTAL TRACKS ARE SECURED AT REAR, AS OUTLINED IN STEP, REAR BACK HANGS, OR DOOR COULD FALL FROM OVERHEAD POSITION CAUSING SEVERE OR FATAL INJURY.

**IMPORTANT:** PRIOR TO INSTALLING THE HORIZONTAL TRACKS, USE CABLES OR CHAINS TO TEMPORARILY SUSPEND THE REAR PORTION OF HORIZONTAL TRACKS.

### WARNING

DO NOT USE ROPES, SINCE EDGES OF HORIZONTAL TRACKS AND ANGLES ARE VERY SHARP.

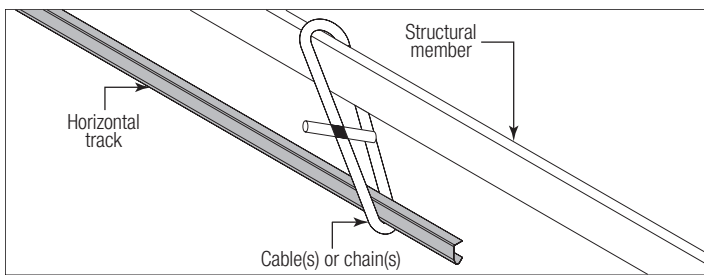

**IF YOU HAVE FLAG ANGLES:** To install horizontal track, place the curved end over the top track roller of the top section. Align the bottom of the horizontal track with the top of the vertical track. Tighten the horizontal track to the flag angle with (2) 1/4" - 20 x 9/16" track bolts and (2) 1/4" - 20 flange hex nuts.

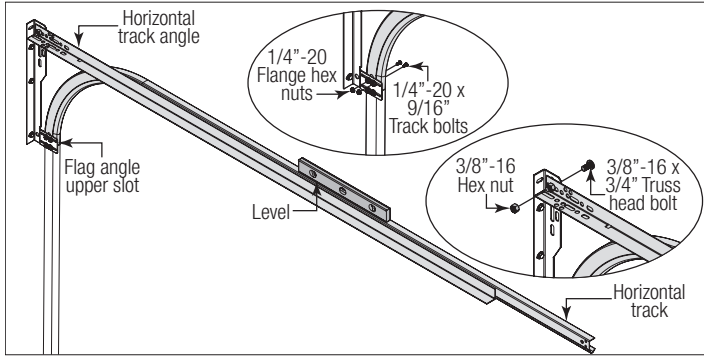

**IF YOU HAVE ANGLE MOUNT:** To install horizontal track, place the curved end over the top track roller of the top section. Align the bottom of the horizontal track with the top of the vertical track. Tighten the horizontal track to the angle mount with (2) 1/4" - 20 x 9/16" track bolts and (2) 1/4" - 20 flange hex nuts.

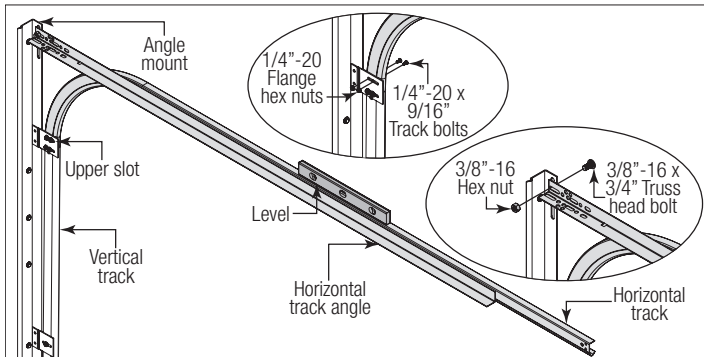

Next level the horizontal track assembly and bolt the horizontal track angle to the first encountered slot in the flag angle / angle mount using (1) 3/8" - 16 x 3/4" truss head bolt and (1) 3/8" - 16 hex nut. Repeat for other side. Remove nail that was temporarily holding the top section in position.

**IMPORTANT:** FAILURE TO REMOVE NAIL BEFORE ATTEMPTING TO RAISE DOOR COULD CAUSE PERMANENT DAMAGE TO TOP SECTION.

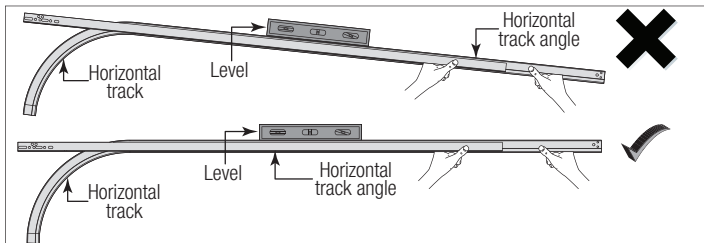

## 17 Adjusting Top Fixtures

With horizontal tracks installed, you can now adjust the top fixtures. Vertically align the top section of the door with the lower sections. Once aligned, position the top fixture slide, out against the horizontal track. Maintaining the slide's position, tighten the 5/16" - 18 hex nut to secure the top fixture slide to the top fixture base. Repeat for other side.

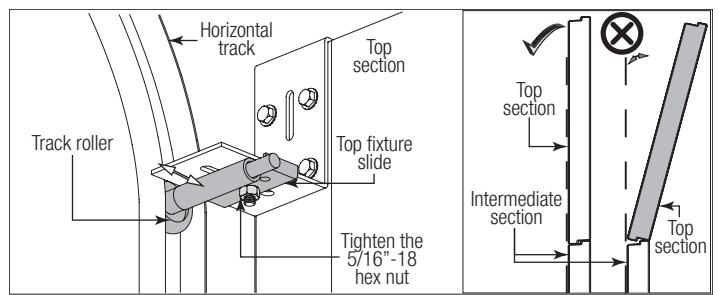

# COUNTERBALANCE INSTALLATION INSTRUCTIONS

## 18 Attaching End Bearing Brackets

**IMPORTANT:** RIGHT AND LEFT HAND IS ALWAYS DETERMINED FROM INSIDE THE BUILDING LOOKING OUT.

### WARNING

**INSTALL END BEARING BRACKETS TO SOLID STRUCTURAL MEMBERS ONLY. DO NOT INSTALL OVER DRY WALL OR PANELING. FAILURE TO INSTALL END BEARING BRACKETS TO SOLID STRUCTURAL MEMBERS CAN CAUSE SEVERE OR FATAL INJURY.**

### WARNING

**FAILURE TO USE PROPER NUMBER OF FASTENERS CAN RESULT IN SUDDEN SPRING TENSION RELEASE, CAUSING SEVERE OR FATAL INJURY.**

**NOTE:** Spring pads must be securely anchored before proceeding, as shown. The pads must be flush with the jambs.

**IMPORTANT:** RIGHT AND LEFT HAND IS ALWAYS DETERMINED FROM INSIDE THE BUILDING LOOKING OUT.

**NOTE:** Refer to Package Contents / Breakdown of Parts to determine which end bearing bracket you have.

**NOTE:** End bearing brackets are right hand and left hand.

Attach the left hand end bearing bracket through either the end bearing bracket's upper or lower slots to the left hand horizontal track angle using (2) 3/8" - 16 x 3/4" truss head bolts and (2) 3/8" - 16 nuts.

**IMPORTANT:** THE END BEARING BRACKET'S LOWER SLOTS ARE USED ON DOORS WITH 12" RADIUS TRACK; THE UPPER SLOTS ARE USED ON DOORS WITH 15" RADIUS TRACK.

**SECURE THE END BEARING BRACKET TO THE JAMB USING ONE OF THE FOLLOWING SCENARIOS LISTED BELOW:**

For wood jambs, using 5/16" x 1-5/8" lag screw(s).

**NOTE:** Prior to fastening end bearing brackets into the door jamb, pilot drill using a 3/16" drill bit.

For steel jambs, using 5/16" x 1" self drilling screw(s).

For pre-cast concrete, using 3/8" x 3" sleeve anchor(s) (not supplied).

**NOTE:** Products being installed to pre-cast or block must use a 3/8" x 3" sleeve anchor to attach the end bearing brackets to the building, as shown. Use the slots in the end bearing bracket as a drill template and drill a 3/8" hole (3-1/2" deep) and secure to anchor.

### WARNING

**DO NOT USE SLEEVE ANCHORS ON HOLLOW BLOCK.**

Repeat the same process for the right hand side.

**NOTE:** This illustration shows 12" or 15" radius track with lag screws to Wood Jambs.

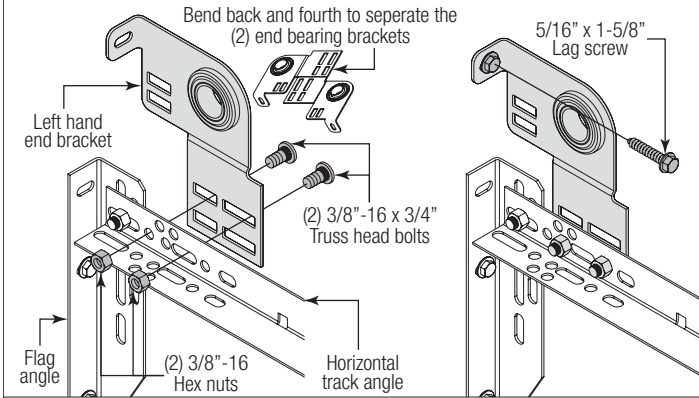

**IMPORTANT:** THE END BEARING BRACKET'S LOWER SLOTS ARE USED ON DOORS WITH 12" RADIUS TRACK; THE UPPER SLOTS ARE USED ON DOORS WITH 15" RADIUS TRACK.

**NOTE:** This illustration shows 15" radius track with lag screws to Wood Jambs.

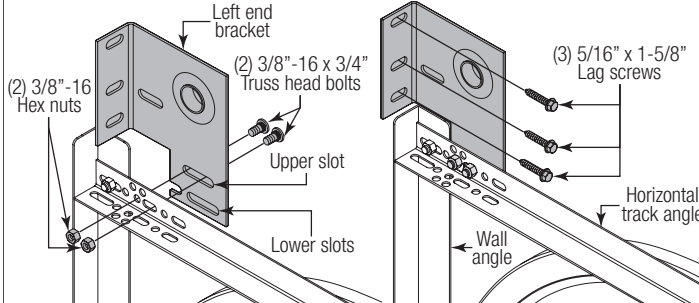

**NOTE:** This illustration shows 12" or 15" radius track with self drilling screws to Steel.

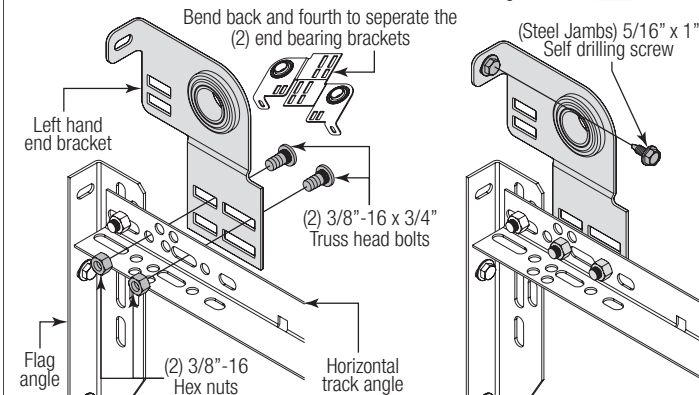

**IMPORTANT:** THE END BEARING BRACKET'S LOWER SLOTS ARE USED ON DOORS WITH 12" RADIUS TRACK; THE UPPER SLOTS ARE USED ON DOORS WITH 15" RADIUS TRACK.

**NOTE:** This illustration shows 15" radius track with self drilling screws to Steel.

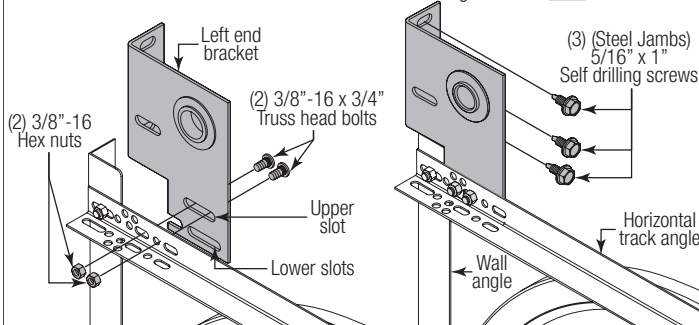

**NOTE:** This illustration shows 12" or 15" radius track with anchors to Concrete.

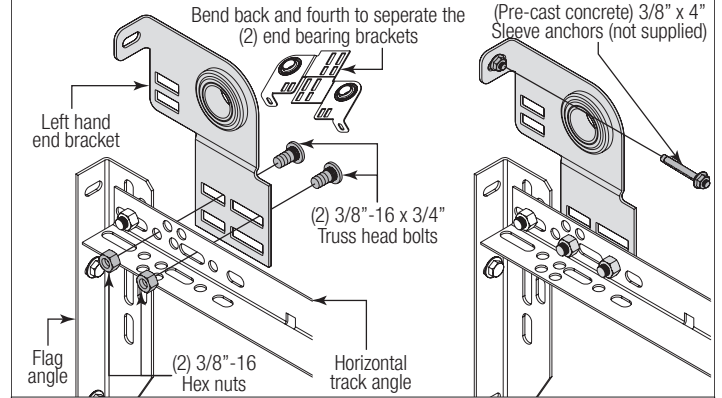

**IMPORTANT:** THE END BEARING BRACKET'S LOWER SLOTS ARE USED ON DOORS WITH 12" RADIUS TRACK; THE UPPER SLOTS ARE USED ON DOORS WITH 15" RADIUS TRACK.

**NOTE:** This illustration shows 15" radius track with anchors to Concrete.

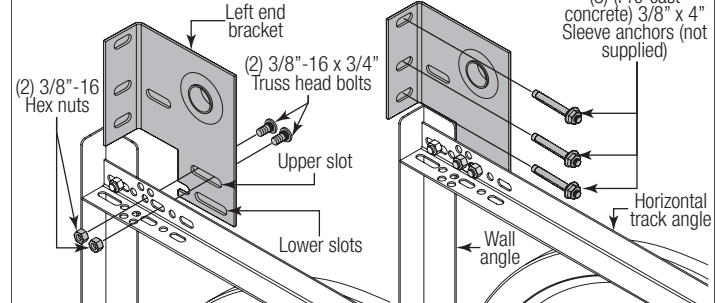

## 19

### Attaching Center Bracket to Wall

**NOTE:** Refer to Package Contents / Breakdown of Parts, to determine which Center Bracket(s) came with your door.

**NOTE:** When attaching the center bracket(s) to the spring pads, it has to be at the same elevation as the bearing in the end bearing brackets.

**NOTE:** Additional center brackets may be required for doors with coupler assembly. Refer to Package Contents / Breakdown of Parts, to determine if you have a coupler assembly.

**NOTE:** If your door came with (4) or more springs, each of the outer springs mounting surface will need to be a minimum of 3" wide.

**NOTE:** If needed, measure the diameter of your springs. If you have a one piece shaft with 3-3/4" or larger diameter springs, they do not share center brackets and do not have a coupler assembly.

First, locate the center of the door. Mark a vertical pencil line on the mounting surface above the door, at the center. Measure from the center of the bearing, in one of the end bearing brackets, downwards, to the top of the door. Using that measurement, measure that distance upwards from the top of the door to the mounting surface and mark a horizontal pencil line which intersects the vertical pencil line.

**NOTE:** On some single spring doors, the spring can be longer than half the opening width. If your spring is longer, then the center bracket must be mounted off center for the spring to fit properly. Measure spring length adding room for spring growth during winding, to determine appropriate center bracket location.

**NOTE:** Depending on the construction, different fasteners must be used.

**FOR WOOD CONSTRUCTION:** Align the edge of the center bracket with the vertical pencil line and the center of the center bracket with the horizontal pencil line; this is to ensure the torsion shaft is level between the center and end bearing brackets. Attach the center bracket to the mounting surface, using 5/16" x 1-5/8" lag screws.

**NOTE:** Drill 3/16" pilot holes into header for the lag screws.

**FOR STEEL CONSTRUCTION:** Secure each center bracket using (4) 5/16" x 1" self-drilling and tapping screws, as shown.

**FOR PRE-CAST CONSTRUCTION:** Secure each center bracket using (2) 1/2" x 3" sleeve anchors (by others). This installation will require the 1/2" anchors to be secured to the building and then secure the brackets to the anchors, as shown.

**NOTE:** Pre-Drill 1/2" pilot holes into the pre-cast for the 1/2" x 3" sleeve anchors.

**FOR BLOCK CONSTRUCTION:** Attach perforated angle 18" long to center bracket(s) using (2) 3/8" x 1-1/4" bolts and (2) 3/8" nuts. Chamfer angle to clear top section high arc. Secure center bracket(s) and perforated angle to block using (4) 3/8" x 2-1/2" sleeve anchors, as shown.



# WARNING

**DO NOT USE SLEEVE ANCHORS ON HOLLOW BLOCK.**

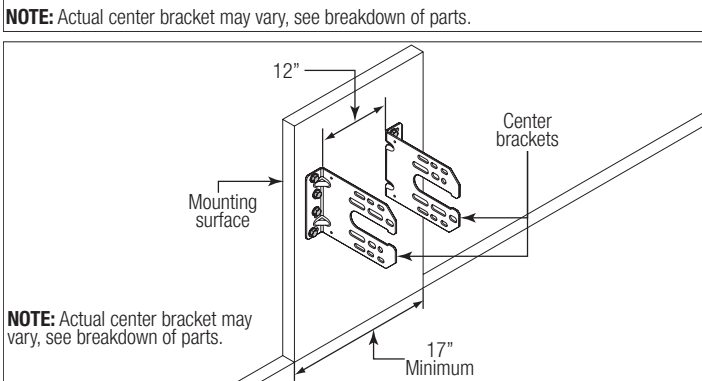
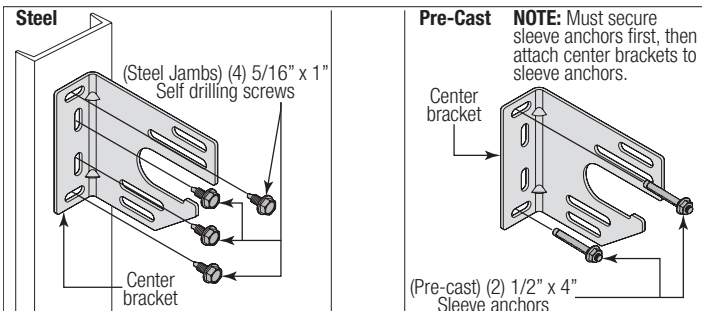
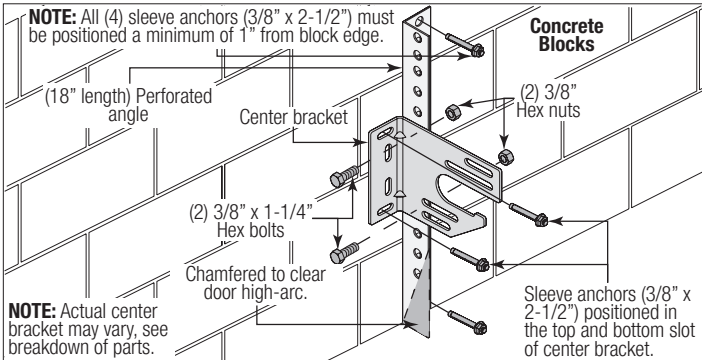
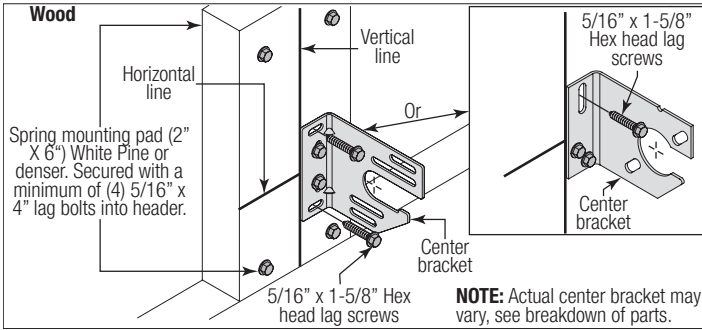

**FOR ALTERNATE STEEL SPRING PAD APPLICATIONS:**  
**IMPORTANT:** DO NOT BOLT TWO 3-3/4\"/>

# WARNING

**THESE SPRING MOUNTING TECHNIQUES ARE NOT SUPPORTED FOR 800-32 CABLE DRUMS. THESE INSTRUCTIONS ARE ALSO NOT APPLICABLE FOR 5750-120 CABLE DRUMS WITH 72\"/>**

# WARNING

**MAXIMUM SPACING FOR DIMENSION "Y" IS 84" (7 FT.). THESE INSTRUCTIONS ARE NOT APPLICABLE FOR A SPAN GREATER THAN 84" ..**

**Maximum Door Size 9'0" x 9'0" (Maximum Door Weight 210 lb.)**

Cut perforated angle (1-5/8" x 2-3/8" x 11 GA.) to Dim "Y". Thru-bolt top and bottom of angle to each girt using (4) 3/8" x 1-1/4" bolts and (4) 3/8" nuts. Thru-bolt center bracket to perforated angle using (3) 3/8" x 1-1/4" bolts and (3) 3/8" nuts, as shown.

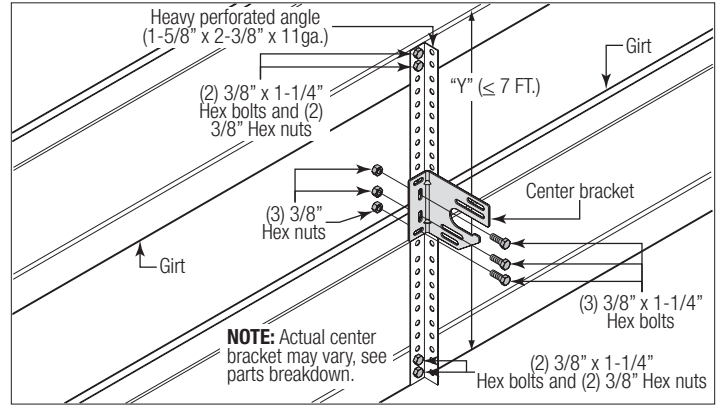

### Maximum Door Size 14'0" x 12'0" (Maximum Door Weight 400 lb.)

Cut (2) perforated angle (1-5/8" x 2-3/8" x 11 GA.) to Dim "Y". Thru-bolt top and bottom of each angle to each girt using (4) 3/8" x 1-1/4" bolts and (4) 3/8" nuts. Thru-bolt each center bracket to perforated angle using (3) 3/8" x 1-1/4" bolts and (3) 3/8" nuts, as shown.

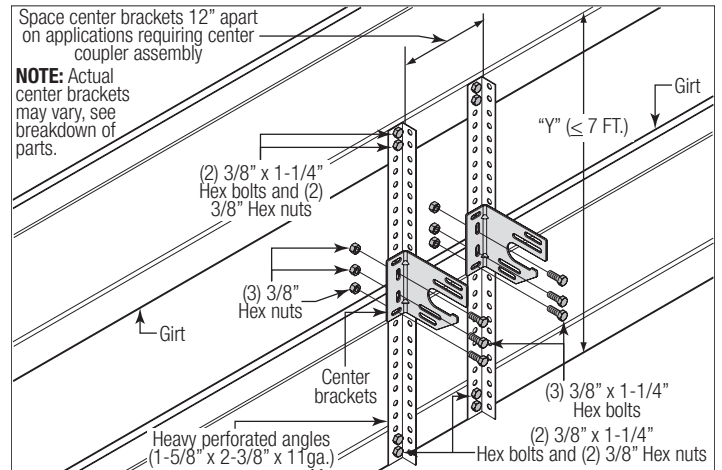

### Maximum Door Size 14'-2" x 12'-1" (Maximum Door Weight 800 lb.)

Cut (2) pieces of perforated angle (1-5/8" x 2-3/8" x 11 GA.) to Dim "Y" and (2) more pieces at Dim "Y" minus 3". Bolt the angles together into a "Z" shape using (4) 3/8" x 1-1/4" bolts and (4) 3/8" nuts. Thru-bolt top and bottom of each "Z" shaped angle to each girt using (4) 3/8" x 1-1/4" bolts and (4) 3/8" nuts. Thru-bolt each center bracket to perforated angle assembly using (3) 3/8" x 1-1/4" bolts and (3) 3/8" nuts, as shown.

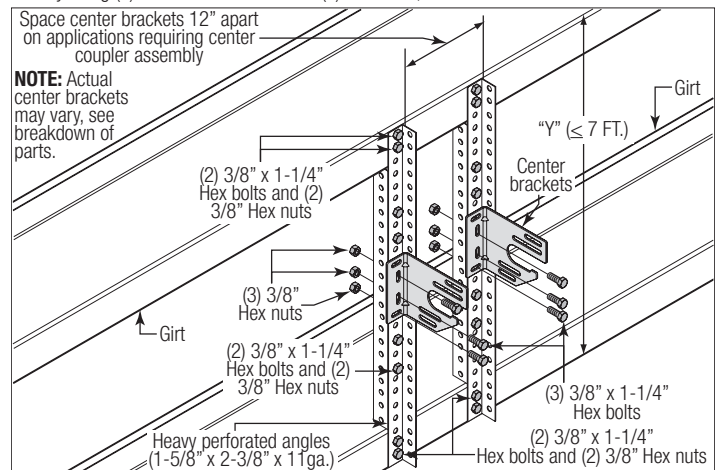

## 20

### Torsion Spring Assembly

**IMPORTANT:** RIGHT AND LEFT HAND IS ALWAYS DETERMINED FROM INSIDE THE BUILDING LOOKING OUT.

**NOTE:** Torsion spring assemblies can be of several configurations depending on your door size and door weight.

**IMPORTANT:** ON SINGLE SPRING APPLICATIONS, ONLY A LEFT HAND WOUND (BLACK

WINDING CONE), WHICH GOES ON THE RIGHT HAND SIDE IS REQUIRED.

**NOTE:** Identify the torsion springs provided as either right hand wound (red winding cone), which goes on the LEFT HAND SIDE or left hand wound (black winding cone), which goes on the RIGHT HAND SIDE.

Facing the inside of the door and referencing the illustrations shown, lay the torsion shaft / torsion keyed shaft(s) on the floor.

**NOTE:** If your door came with (2) torsion keyed shafts, one torsion keyed shaft should be on the left hand side of the floor and the other torsion keyed shaft should be on the right hand side of the floor.

Lay the torsion spring(s) with the black winding cone and the black cable drum at the right end of the torsion shaft / torsion keyed shaft(s). Lay the torsion spring(s) with the red winding cone and the red cable drum at the left end of the torsion shaft / torsion keyed shaft(s).

**NOTE:** The set screws used on all torsion winding cones and cable drums are colored red. DO NOT identify right and left hand by the set screw color.

**IF YOUR DOOR CAME WITH A COUPLER ASSEMBLY:** Disassemble the coupler assembly by removing the (3) 3/8" - 16 x 1-3/4" hex head screws and the (3) 3/8" - 16 nylon hex lock nuts from the coupler halves. Loosen the set screws. Slide the flat edge of the coupler half flush with the side edge of the torsion keyed shaft. Insert (1) key into the slot of both the coupler halves and the slot in the torsion keyed shaft. Tighten the (2) set screws and the locking nut to secure the coupler half to the torsion keyed shaft, as shown.

**NOTE:** Tighten the set screws to 14-15 ft-lbs (Once set screws contact the shaft, tighten screws an additional 1/2 turn).

Repeat the same processes for the other coupler half.

**IMPORTANT:** THE COUPLER HALVES, CENTER BEARING(S), TORSION SPRINGS, AND CABLE DRUMS MUST BE POSITIONED, AS SHOWN IN THE ILLUSTRATIONS.

### Single Spring Or Double Springs Applications, 1 Piece Shaft, 3-3/4" and 6" Springs

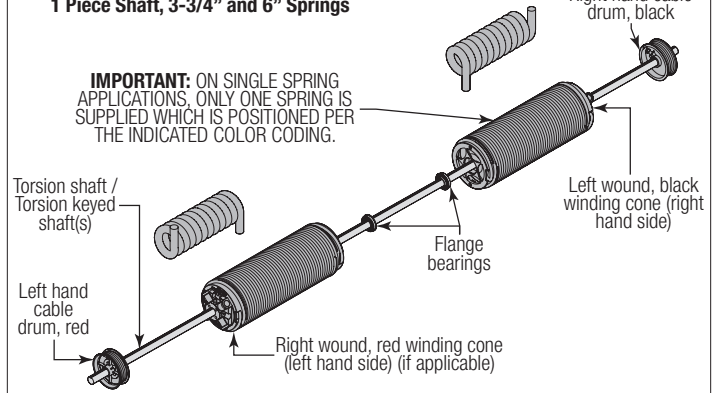

### Double Springs Applications, 2 Piece Shafts, Two or 4 springs, up to 6" Springs.

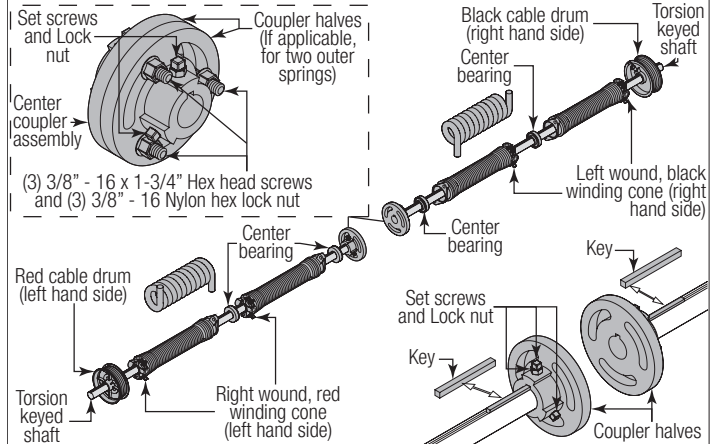

**IF YOUR DOOR DOESN'T HAVE A COUPLER ASSEMBLY:** With assistance, pick up the torsion spring assembly and slide one end of the torsion shaft / torsion keyed shaft through one end bearing bracket. Lay the middle of the torsion shaft / torsion keyed shaft into the center bracket. Slide the other end of the torsion shaft / torsion keyed shaft into the other end bearing bracket. Position the torsion shaft / torsion keyed shaft so that equal amounts of the shaft extend from each of the end bearing brackets.

**NOTE:** Position the torsion shaft so that equal amounts of the shaft extend from each end bearing bracket.

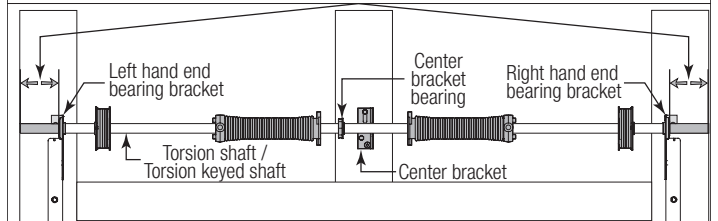

**IF YOUR DOOR HAS A COUPLER ASSEMBLY:** With assistance and starting on the left hand side of door, pick up the left hand torsion spring assembly and slide one end of the torsion keyed shaft through the end bearing bracket. Lay the other side of the torsion keyed shaft into the center bracket. Repeat the same process for the right hand torsion spring assembly. Position both torsion keyed shafts so that equal amounts of the shafts extend from each of the end bearing brackets.

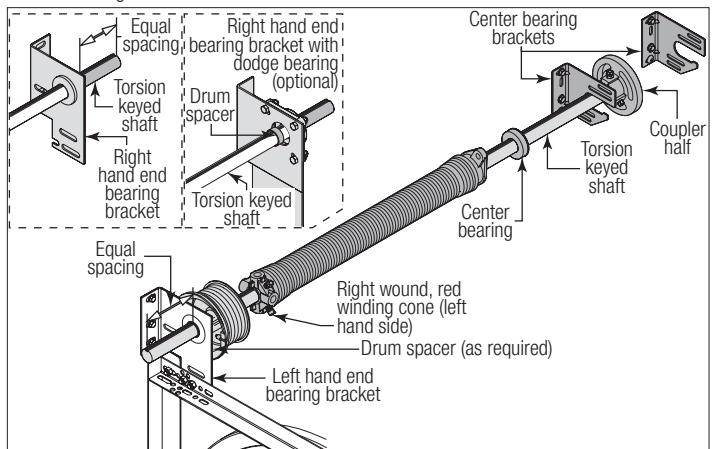

### Single Spring Or Double Springs Applications, 1 Piece Shaft, Up To 2-5/8" Springs

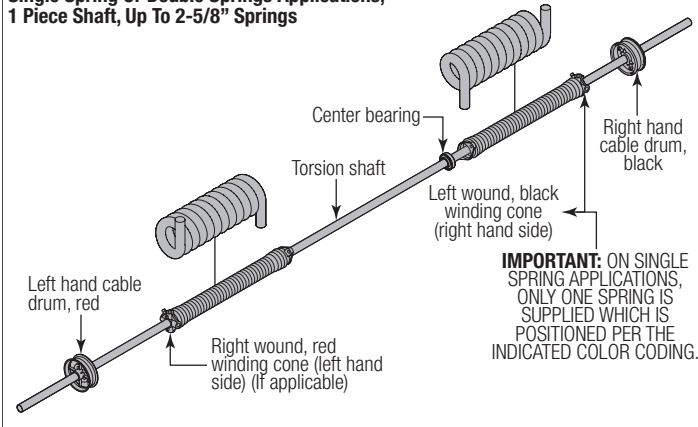

### Double Springs Applications, Two Or Four Springs, 1 Piece Shaft, Up To 2-5/8" Springs

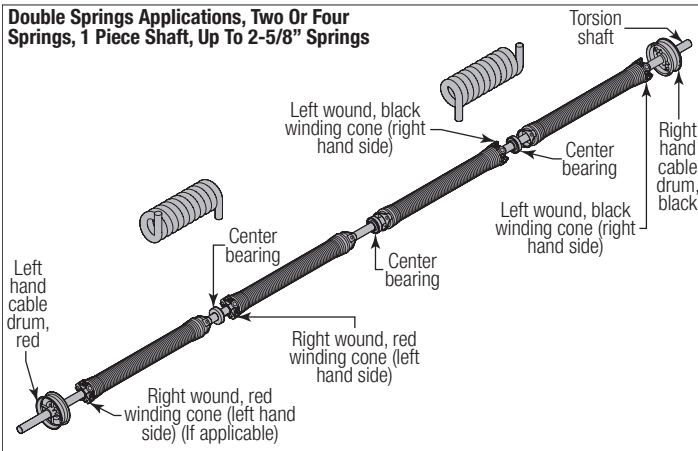

**NOTE:** Refer to Package Contents / Breakdown of Parts, to determine which Center Bracket(s) came with your door.

**NOTE:** Refer to Package Contents / Breakdown of Parts, to determine if your door came with a coupler assembly.

**IMPORTANT:** THE SPRING WARNING TAG(S) SUPPLIED MUST BE SECURELY ATTACHED TO THE STATIONARY SPRING CONE(S) IN PLAIN VIEW. SHOULD A REPLACEMENT SPRING WARNING TAG BE REQUIRED, CONTACT WAYNE DALTON FOR FREE REPLACEMENTS.

**NOTE:** Measure the diameter of your springs. If your spring diameter is 3-3/4", the springs do not share center brackets. If your spring diameter is either 2" or 2-5/8", then two springs will share the same center bracket, unless a coupler assembly is provided.

**IF YOU DON'T HAVE A COUPLER ASSEMBLY:** Slide center bracket bearing into the spring. Align the stationary spring cone(s) with the holes in the center bracket. Secure the torsion spring(s) to the center bracket with (2) 3/8" - 16 x 1-1/2" hex head bolts and (2) 3/8" - 16 nuts.

**IMPORTANT:** NEVER USE MORE THAN ONE BEARING WHEN ATTACHING TWO SPRINGS TO ONE CENTER BRACKET.

**IF YOU HAVE A COUPLER ASSEMBLY:** Slide center bracket bearing into the spring. Align the stationary spring cone with the holes in the center bracket. Secure the torsion spring to the center bracket with (2) 3/8" - 16 x 1-1/2" hex head bolts and (2) 3/8" - 16 nuts. Repeat the same process for the other center bearing bracket.

At the middle of the two center bearing brackets, re-assemble the coupler assembly by loosely fastening the coupler halves together using the (3) 3/8" - 16 x 1-1/2" hex head screws, (6) 3/8" washers, (3) 3/8" lock washers and the (3) 3/8" - 16 hex nuts, previously removed.

**NOTE:** Ensure both torsion keyed shafts have equal amounts of the shafts extending from each end bearing bracket.

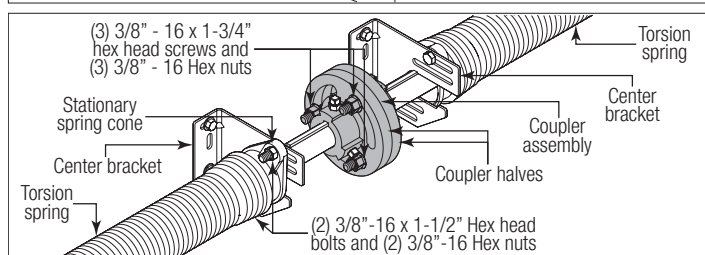
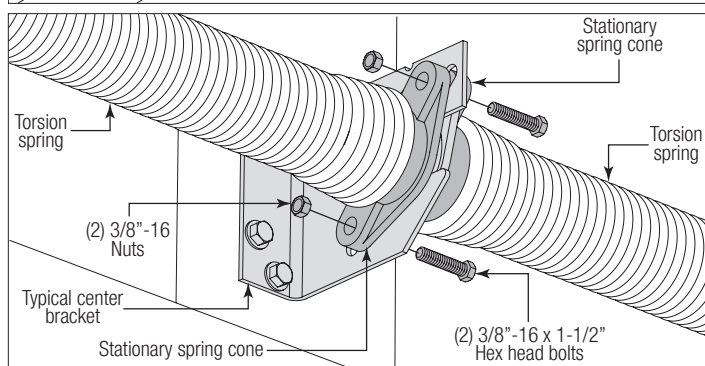
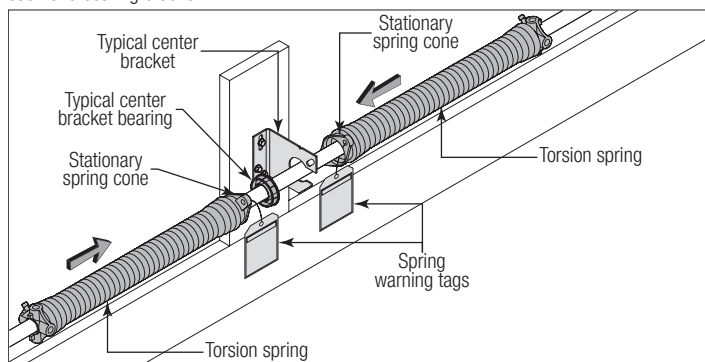

**NOTE:** Refer to Package Contents / Breakdown of Parts, to determine which Center Bracket(s) came with your door.

**NOTE:** Refer to Package Contents / Breakdown of Parts, to determine if your door came with a coupler assembly.

**IMPORTANT:** THE SPRING WARNING TAG(S) SUPPLIED MUST BE SECURELY ATTACHED TO THE STATIONARY SPRING CONE(S) IN PLAIN VIEW. SHOULD A REPLACEMENT SPRING WARNING TAG BE REQUIRED, CONTACT WAYNE DALTON FOR FREE REPLACEMENTS.

**FOR SPRINGS UP TO 3-3/4" ID AND IF YOU DON'T HAVE A COUPLER ASSEMBLY:** Slide center bearing into the spring (if applicable). Align the stationary spring cone(s) with the holes in the center bracket assembly. Secure the torsion spring(s) to the center bracket assembly with (2) 3/8" - 16 x 1-1/2" hex head bolts and (2) 3/8" - 16 nuts.

**IF YOU HAVE A COUPLER ASSEMBLY:** Slide the center bearing into the spring. Align the stationary spring cone with the holes in the center bearing bracket.

**NOTE:** Prior to attaching the torsion spring(s) to the center bracket(s), the torsion shaft / torsion keyed shafts have to be at the same elevation as the bearing in the end bearing brackets. Slide the torsion shaft / torsion keyed shafts out to the correct shaft centerline from the jambs before tightening the spring assembly fasteners.

**FOR SPRINGS UP TO 3-3/4" ID:** Secure the torsion spring to the center bracket with (2) 3/8" - 16 x 1-1/2" hex head bolts and (2) 3/8" - 16 nuts. Repeat the same process for the other center bearing bracket.

**FOR 6" AND DUPLEX SPRINGS:** Secure the torsion spring and the flange bearing to the center bracket using (2) 3/8" - 16 x 1" Hex head bolts, as shown.

## WARNING

**FOR DUPLEX SPRINGS, YOU MUST ENSURE THE ASSEMBLY BOLTS GO THROUGH THE CENTER BRACKET AND INNER SPRING CONE AND THREAD INTO THE OUTER SPRING CONE AS SHOWN. FAILURE TO ENSURE THE BOLTS ARE SECURING BOTH THE INNER AND OUTER SPRING CONES TO THE CENTER BRACKET CAN RESULT IN SUDDEN SPRING TENSION RELEASE, CAUSING SEVERE OR FATAL INJURY.**

At the middle of the two center bearing brackets, loosely re-assemble the coupler assembly by fastening the coupler halves together using the (3) 3/8" - 16 x 1-3/4" hex head screws and the (3) 3/8" - 16 nylon hex lock nuts, as shown.

**NOTE:** Ensure both torsion keyed shafts have equal amounts of the shafts extending from each end bearing brackets.

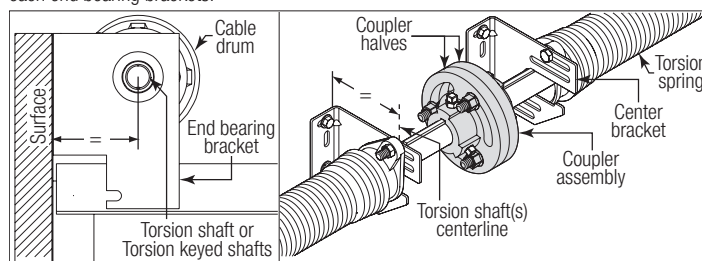

### Up To 3-3/4" Springs Applications

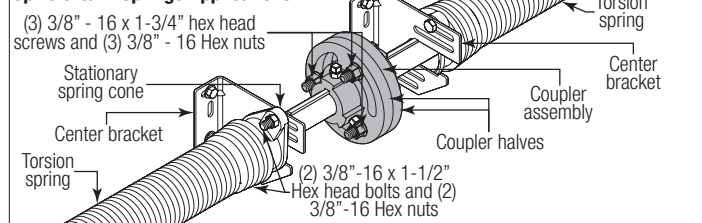

### 6" Springs Applications

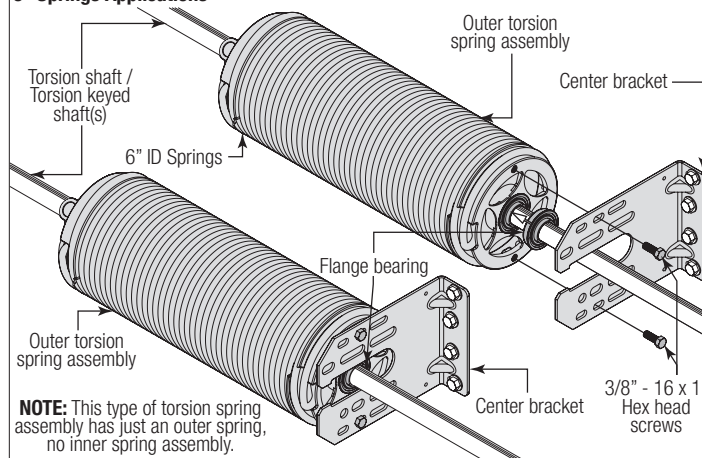

**NOTE:** This type of torsion spring assembly has just an outer spring, no inner spring assembly.

## 6" Duplex Springs Applications

**NOTE:** Prior to securing the center bracket to the torsion spring, ensure the bolt goes through the inner spring cone and threads into the outer spring cone.

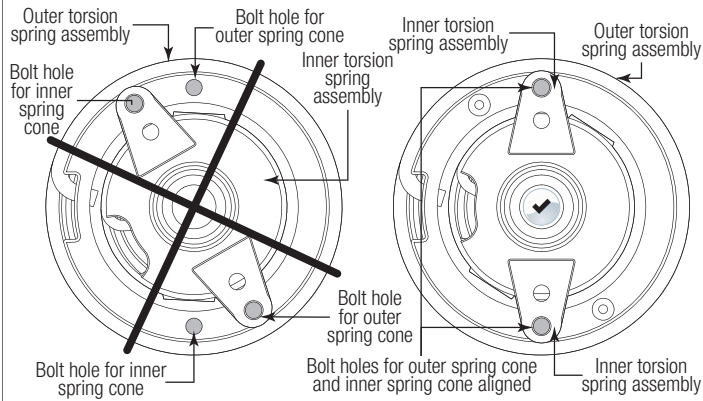

## 6" Duplex Springs Applications

**NOTE:** This type of torsion spring assembly has both an outer spring and an inner spring assembly.

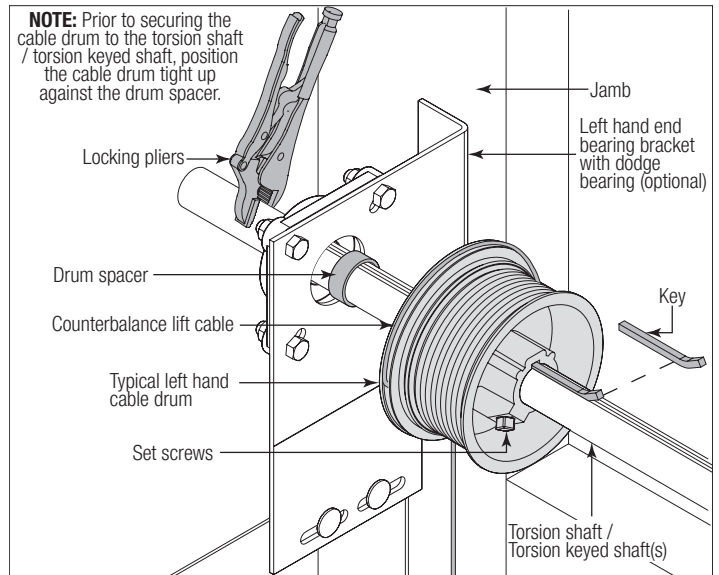
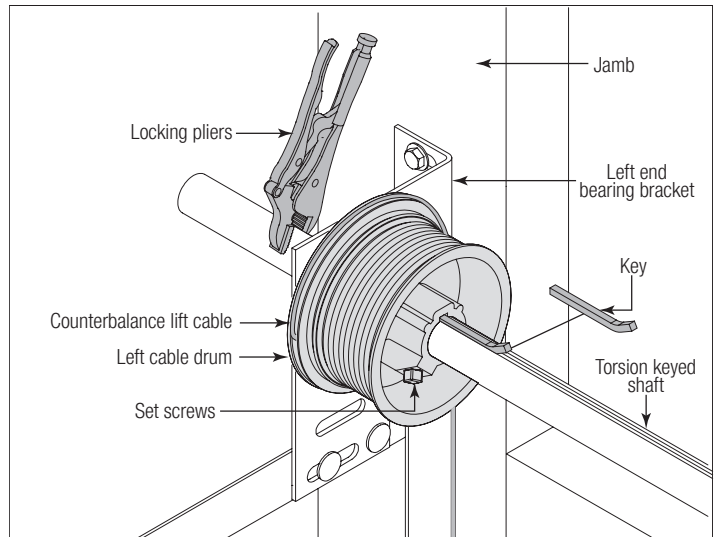
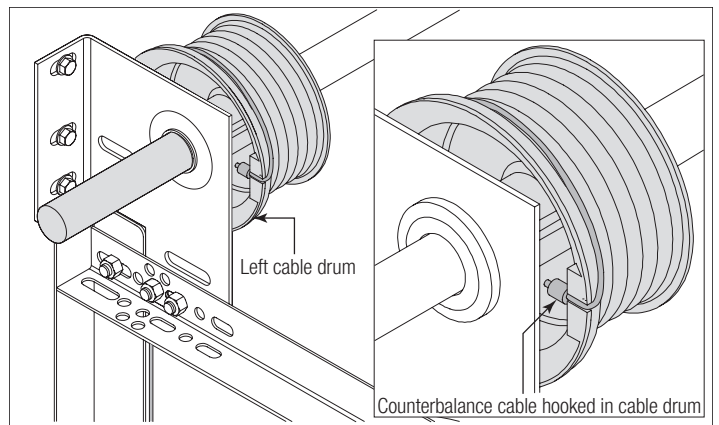
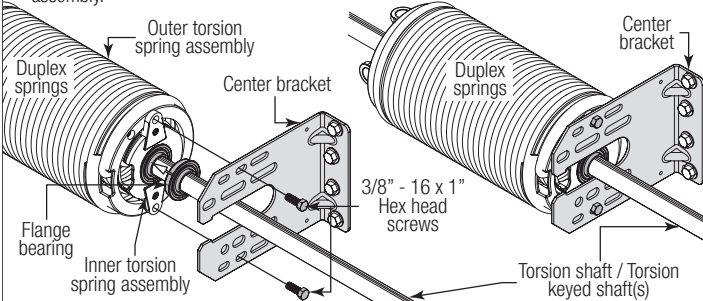

## 22 Attaching Counterbalance Lift Cables

Starting on the left hand side, thread the counterbalance lift cable up and around the front side of the left hand cable drum.

**IMPORTANT:** VERIFY THAT THERE ARE NO OBSTRUCTIONS IN THE TRAVEL PATH OF THE DOOR SECTIONS OR COUNTERBALANCE LIFT CABLES.

**NOTE:** Always assemble the left hand cable and cable drum first to help maintain equal cable tension on both sides of the door.

Hook the counterbalance lift cable into the left hand cable drum. Slide the left hand cable drum up against the left hand end bearing bracket / spacer. Counterbalance lift cable should terminate at the 3 o'clock position.

**NOTE:** If you have torsion keyed shaft(s), insert (1) key into the slot of both the cable drum and the slot in the torsion keyed shaft, as shown.

At the middle of the two center bearing brackets, loosen the (3) 3/8" - 16 x 1-3/4" hex head screws and the (3) 3/8" - 16 nylon hex lock nuts from the coupler assembly (if applicable).

Rotate the left hand drum and torsion shaft until counterbalance lift cable is taut. Now attach locking pliers to the torsion shaft and brace locking pliers up against jamb to keep counterbalance lift cable taut. Tighten the set screws in the drum to 14-15 ft-lbs (Once set screws contact the shaft, tighten screws an additional 1/2 turn for solid shaft and 1 full turn for tubular shaft). Repeat for right hand side.

At the middle of the two center bearing brackets, tighten the (3) 3/8" - 16 x 1-3/4" hex head screws and the (3) 3/8" - 16 nylon hex lock nuts from the coupler assembly (if applicable).

**IMPORTANT:** INSPECT EACH COUNTERBALANCE LIFT CABLE MAKING SURE IT IS SEATED PROPERLY ONTO THE CABLE DRUM AND THAT BOTH COUNTERBALANCE LIFT CABLES HAVE EQUAL TENSION.

### CHECK COUNTERBALANCE LIFT CABLES FOR EQUAL TENSION:

1. Attach locking pliers to track above top roller.
2. Grasp cable at approximate mid-door height location.
3. Draw cable toward you about 1/2" to 1" and release, noting the response of the cable.
4. Repeat above steps for other cable.
5. Adjust cable tension as needed until right and left cables both respond the same.

Once the counterbalance cables are set and if applicable tighten the coupler assembly together by tightening the (3) 3/8" - 16 nylon hex nuts to secure the coupler halves together.

## 23 Chalking Torsion Spring(s)

**NOTE:** If your springs have stenciling, then skip this step.

Draw a chalk line horizontally along the center of the torsion spring coil(s). As the torsion spring is wound, the chalk line will create a spiral. This spiral can be used to count and determine the number of turns that are applied on the torsion spring.

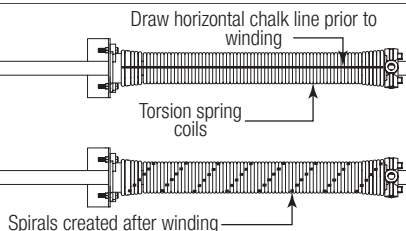

## 24 Securing Door for Spring Winding

With the door in the fully closed position, place locking pliers onto both vertical tracks just above the third track roller. This is to prevent the garage door from rising while winding springs.

**NOTE:** Check the following before attempting to wind torsion spring(s):

- Counterbalance lift cables are secured at bottom corner brackets.
- Counterbalance lift cables are routed unobstructed to cable drums.
- Counterbalance lift cables are correctly installed and wound onto cable lift drums.
- Counterbalance lift cables are taut and have equal tension on both sides.
- Cable lift drums are against end bearing brackets and set screws are tight.
- Torsion spring or springs are installed correctly.
- Review the label attached to the spring warning tag, to determine number of spring turns required.

**NOTE:** Door **MUST** be closed and locked when winding or making any adjustments to the torsion spring(s).

### WARNING

**FAILURE TO ENSURE DOOR IS IN A CLOSED POSITION AND TO PLACE LOCKING PLIERS ONTO VERTICAL TRACK CAN ALLOW DOOR TO RISE AND CAUSE SEVERE OR FATAL INJURY.**

Winding Bars (Steel Rods)	Size Of Winding Bar (Inches)	Spring Inner Diameter Used On
—	1/2" dia. x 18"	2" and 2-5/8"
—	5/8" dia. x 24"	3-3/4"

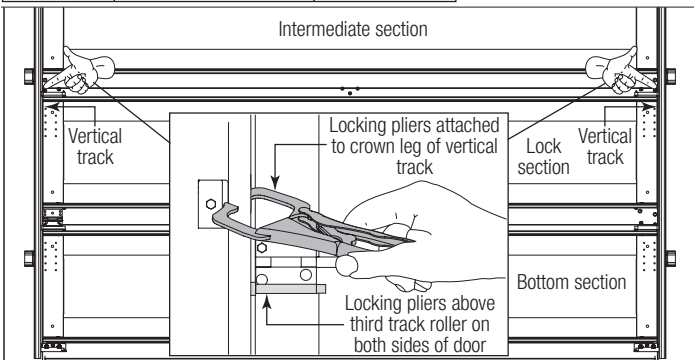

## 25 Winding Spring(s)

### WARNING

**WINDING SPRING IS AN EXTREMELY DANGEROUS PROCEDURE AND SHOULD BE PERFORMED ONLY BY A TRAINED DOOR SYSTEM TECHNICIAN USING PROPER TOOLS AND INSTRUCTIONS.**

### WARNING

**USE ONLY SPECIFIED WINDING BARS, AS STATED IN STEP SECURING DOOR FOR SPRING WINDING. DO NOT SUBSTITUTE WITH SCREWDRIVERS, PIPE, ETC. OTHER TOOLS MAY FAIL OR RELEASE FROM THE SPRING CONE AND CAUSE SEVERE OR FATAL INJURY.**

### WARNING

**PRIOR TO WINDING THE SPRING, ENSURE YOU'RE WINDING IN THE PROPER DIRECTION AS SHOWN BELOW. OTHERWISE THE SPRING FITTING MAY RELEASE FROM SPRING AND RESULT IN SEVERE OR FATAL INJURY.**

Position a ladder slightly to the side of the spring so that the winding cone is easily accessible, and so your body is not directly in line with the winding bars.

Check the label attached to the spring warning tag for the required number of complete turns to balance your door.

#### HOW TO WIND TORSION SPRINGS:

- Insert one winding rod snugly into winding cone, to full socket depth
- Maintaining a tight grip on the winding rod rotate it slowly in the proper direction, as shown below.
- If there is any slippage of the winding rod in the winding cone socket, reverse the direction of winding and return the cone to its original position. Remove the winding rod from the winding cone socket. Reseat the winding rod in the socket. Start over at Step #1.
- When the winding rod is vertical above the winding cone, insert another winding rod into one of the other sockets, being careful to seat it snugly and at full socket depth.
- Hold the spring with the second winding bar, and remove the first.
- Repeat Steps #2 through #5 until the complete turns have been applied.

**FOR SPRINGS UP TO 3-3/4" ID:** Securely hold the winding rod while tightening the 2 set screws in the winding cone to 14-15 ft-lbs of torque (once set screws contact the torsion shaft, tighten screws an additional 1/2 turn for solid shaft and one full turn for tubular shaft).

Torsion spring(s) should be wound in the direction the end coil points.

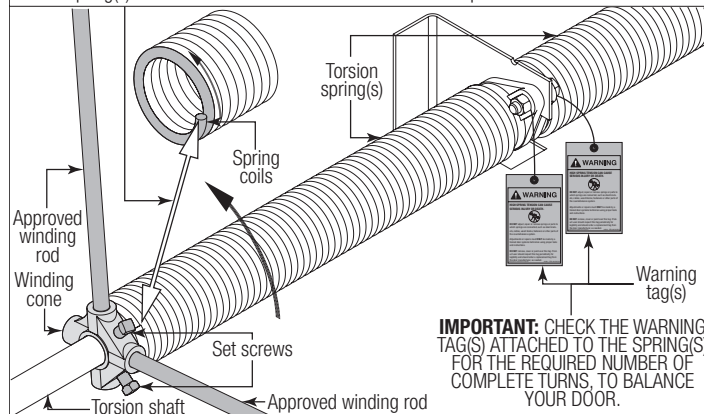

**IMPORTANT:** CHECK THE WARNING TAG(S) ATTACHED TO THE SPRING(S) FOR THE REQUIRED NUMBER OF COMPLETE TURNS, TO BALANCE YOUR DOOR.

**FOR 6" AND DUPLEX SPRINGS:** Securely hold the winding rod while tightening the 4 set screws in the winding cone to 25 ft-lbs of torque (once set screws contact the torsion shaft, tighten an additional 1/2 turn).

**IMPORTANT:** IF YOU HAVE TORSION KEYED SHAFT(S), ONE OF THE SET SCREWS WILL NEED TO BE TIGHTENED INTO THE KEYWAY OF THE TORSION KEYED SHAFT(S).

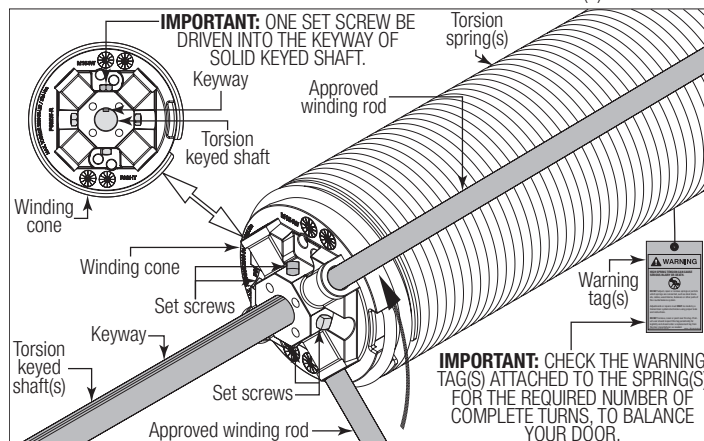

**IMPORTANT:** ONE SET SCREW BE DRIVEN INTO THE KEYWAY OF SOLID KEYED SHAFT. **IMPORTANT:** CHECK THE WARNING TAG(S) ATTACHED TO THE SPRING(S) FOR THE REQUIRED NUMBER OF COMPLETE TURNS, TO BALANCE YOUR DOOR.

After the torsion spring is secure, use the winding rod to apply pressure in the opposite direction to ensure the set screws are securely fixed to the torsion shaft.

Carefully remove winding rod from winding cone. Repeat for remaining springs, if applicable. While holding the door down to prevent it from raising unexpectedly in the event the spring(s) were over-wound, carefully remove the locking pliers from the torsion shaft and vertical tracks.

**NOTE:** If you have a coupler assembly, it may be necessary to loosen and retighten the (3) 3/8" - 16 x 1-3/4" hex head screws and the (3) 3/8" - 16 nylon hex lock nuts assembly bolts to equalize the cable tension on both sides of the door.

Adjustments to the number of turns stated may be necessary. If door rises off floor under spring tension alone, reduce spring tension until door rests on the floor. If the door is hard to rise or drifts down on its own, add spring tension.

**NOTE:** An unbalanced door such as this can cause garage door opener operation problems.

## WARNING

**DO NOT OPEN DOOR UNTIL STEP REAR BACK HANGS IS COMPLETED.**

# 26

## Attaching Rear Back Hangs

**IMPORTANT:** HOLD THE DOOR DOWN TO PREVENT IT FROM RISING UNEXPECTEDLY IN THE EVENT THE SPRING(S) WERE OVER-WOUND AND CAUTIOUSLY REMOVE LOCKING PLIERS FROM VERTICAL TRACKS.

Raise the door until the top section and half of the next section are in the horizontal track radius. Do not raise door any further since rear of horizontal tracks are not yet supported.

## WARNING

**RAISING DOOR INTO THE LOOSE HORIZONTAL TRACKS CAN RESULT IN DOOR FALLING AND CAUSE SEVERE OR FATAL INJURY.**

Clamp a pair of locking pliers onto the vertical tracks just above the second track roller on one side, and just below the second track roller on the other side. This will prevent the door from raising or lowering while installing the rear back hangs.

Using the chart below, select the appropriate perforated angle (may not be supplied). Fabricate and install rear back hangs, as shown.

**Perforated Angle Gauge Weight Limitations:**

Perforated Angle Gauge	Door Balance Weight
2" x 2" x 12 Gauge	800 lbs. to 1600 lbs.
1-1/4" x 1-1/4" x 13 Gauge	305 lbs. to 610 lbs.
1-1/4" x 1-1/4" x 15 Gauge	220 lbs. to 440 lbs.
1-1/4" x 1-1/4" x 16 Gauge	175 lbs. to 350 lbs.

**NOTE:** If an opener is installed, position horizontal tracks one hole above level when securing it to the rear back hangs.

## WARNING

**MAKE SURE BACK HANGS ARE BRACED SUFFICIENTLY TO RESIST ANY MOTION DURING SPRING APPLICATION AND DOOR TRAVEL. IF BACK HANGS PIVOT OR DEFLECT, ADD REINFORCEMENT UNTIL THEY REMAIN FIRM AND STATIONARY. ANY BACK HANG THAT IS BENT MUST BE REPLACED.**

## WARNING

**KEEP HORIZONTAL TRACKS PARALLEL AND WITHIN 3/4" TO 7/8" FROM DOOR EDGE, OTHERWISE DOOR COULD FALL, RESULTING IN SEVERE OR FATAL INJURY.**

**NOTE:** Doors heights over 8'0" or door widths over 11'0", require an additional set of rear center back hangs to be installed and located at the middle of the horizontal tracks, see breakdown of parts.

Based on your door width and door heights and using perforated angle (may not be supplied), (2) 5/16" x 1-5/8" hex head lag screws and (3) 5/16" bolts with nuts (may not be supplied), fabricate rear center back hangs for the horizontal tracks, for the following:

**FOR ITEM J2, (SEE BREAKDOWN OF PARTS):** The Rear Center Back Hang Assemblies are to be used for all doors over 11'0" door height and over 14'0" door width. One Rear Center Back Hang Assembly, per side.

**FOR ITEM J3, (SEE BREAKDOWN OF PARTS):** The Rear Center Back Hang Assemblies are to be used for all doors over 16'0" door height. Two Rear Center Back Hang Assemblies, per side.

Measure and drill a 3/8" diameter hole through the center length of the horizontal track, as shown. Attach the rear center back hangs to the horizontal tracks with (1) 3/8" Truss head bolt and (1) 3/8" nut (may not be supplied).

**IMPORTANT:** DO NOT SUPPORT THE WEIGHT OF THE DOOR ON ANY PART OF THE REAR BACK HANGS THAT CANTILEVERS 4" OR MORE BEYOND A SOUND FRAMING MEMBER.

**NOTE:** If rear back hangs are to be installed over drywall, use (2) 5/16" x 2" hex head lag screws and make sure lag screws engage into solid structural lumber.

## WARNING

**FAILURE TO ASSEMBLE AND ATTACH REAR BACK HANGS PROPERLY ACCORDING TO THE ABOVE INSTRUCTIONS MAY RESULT IN DOOR FALLING WHEN RAISED, CAUSING SEVERE OR FATAL INJURY.**

**NOTE:** Perforated angle must be attached to sound framing members and **nails should not be used**.

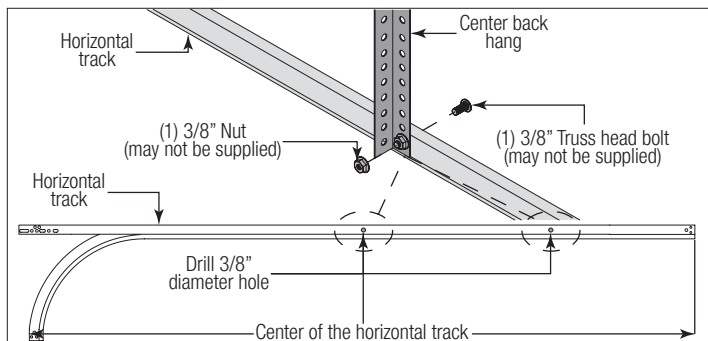
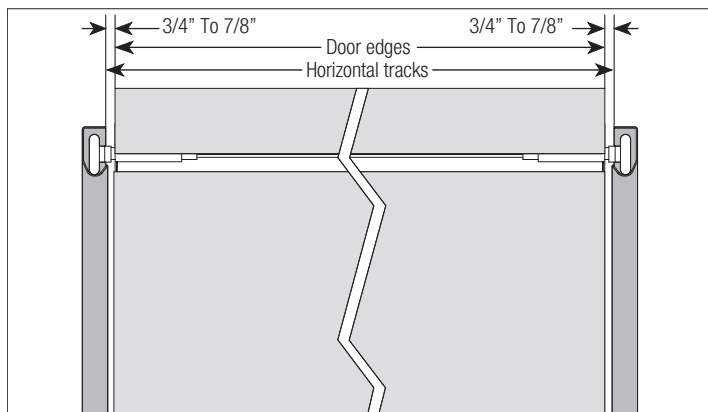
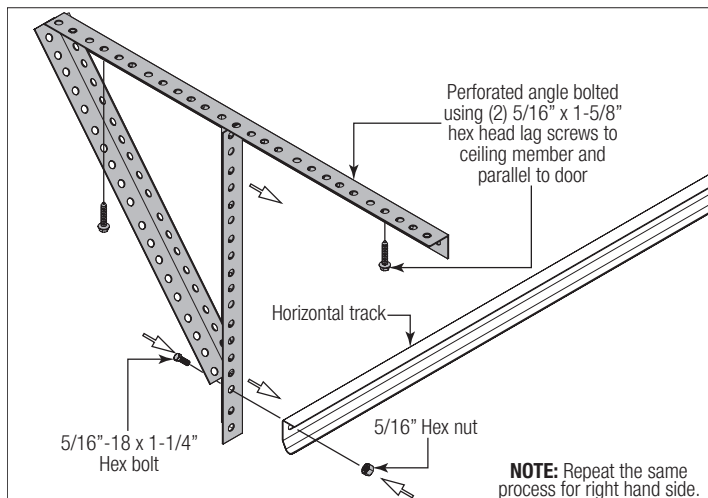
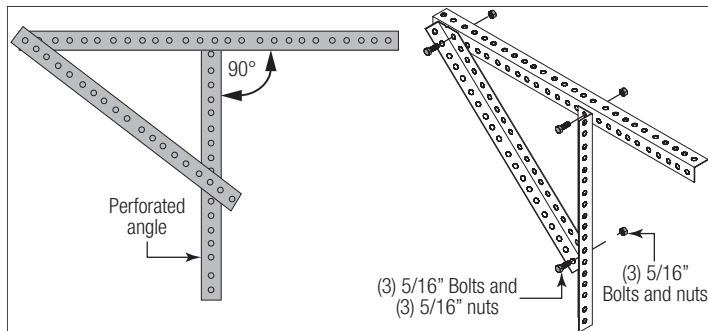

# 27

## Cable Keepers

**NOTE:** If you don't have cable keepers, then skip this step. Refer to Step 4 Attaching Cable Keepers, to determine if you have cable keepers installed.

**IMPORTANT:** CABLE KEEPERS ARE INTENDED TO HELP PREVENT COUNTERBALANCE LIFT CABLES FROM COMING OFF CABLE DRUMS ON MANUALLY OPERATED DOORS. ADDITIONAL CABLE TENSIONING PROVISIONS MAY BE REQUIRED FOR MOTOR OPERATED DOORS.

Rotate arm up and hook around counterbalance lift cable, letting the cable keeper arm pull against the counterbalance lift cable, keeping it taut, as shown. Next, close the hook to prevent the counterbalance lift cables from coming out.

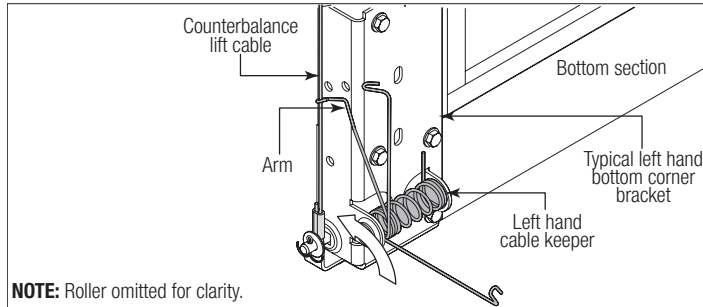

- 2.) Are the torsion shaft and flag angles / angle mount level and plumb?
- 3.) Does the distance between the flag angles / angle mount equal door width plus 3-3/8" to 3-1/2"?
- 4.) Do the counterbalance lift cables have equal tension? Adjust if necessary.
- 5.) Rewind the spring(s).
- 6.) Make sure door is not rubbing on jambs.

**IMPORTANT:** IF DOOR STILL DOES NOT BALANCE PROPERLY, THEN CONTACT A TRAINED DOOR SYSTEM TECHNICIAN.

## 28

### Attaching Weather Seal

**NOTE:** If you don't have weather seals, then skip this step. Refer to Package Contents / Breakdown of Parts, to determine if you have weather seals.

Permanently attach the weatherstrips on both door jambs and header. The weatherstrips were temporarily attached in Preparing the Opening, in the pre-installation section of this manual.

**NOTE:** When permanently attaching the weatherstrips to the jambs, avoid pushing the weatherstrips too tightly against the face of door.

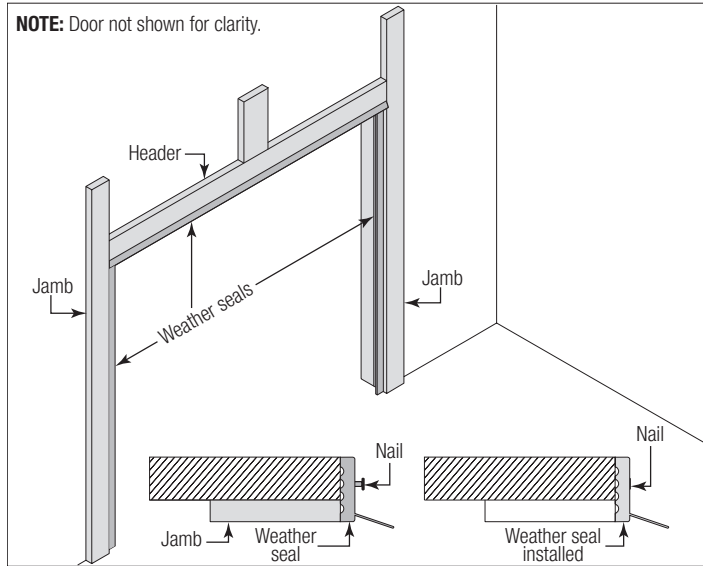

## 29

### Balancing Door

Remove locking pliers. Lift door and check its balance. Adjustments to the required number of spring turns stated may be necessary. If door rises off floor more than 2 ft. under spring tension alone, reduce spring tension. If the door is hard to rise or drifts down on its own, add spring tension. A poorly balanced door can cause garage door operator problems.

To adjust spring tension, fully close door. Apply locking pliers to track above third track roller. Place locking pliers on torsion shaft, as shown in Step Attaching Counterbalance Lift Cables. Insert a winding rod into the winding cone. Push upward on the winding rod slightly while carefully loosening the set screws in the winding cone.

**IMPORTANT:** BE PREPARED TO SUPPORT THE FULL FORCE OF THE TORSION SPRING ONCE THE SET SCREWS ARE LOOSE.

Carefully adjust spring tension 1/4 turn. Retighten both set screws to 14-15 ft. lbs. of torque in the winding cone and repeat for the other side. Recheck door balance and re-adjust spring tension if needed.

**IMPORTANT:** DO NOT ADJUST MORE THAN 1 TURN FROM THE RECOMMENDED NUMBER OF TURNS.

If the door still does not operate easily, lower the door into the closed position, unwind spring(s) completely, and recheck the following items:

- 1.) Is the door level?

## Trolley Arm Hookup

**NOTE:** If Wayne Dalton operator / trolley bracket was installed, follow these directions. Align hole in the door arm with holes in perforated angles, as shown. Attach with (1) 5/16" hex bolt and lock nut (supplied by others).

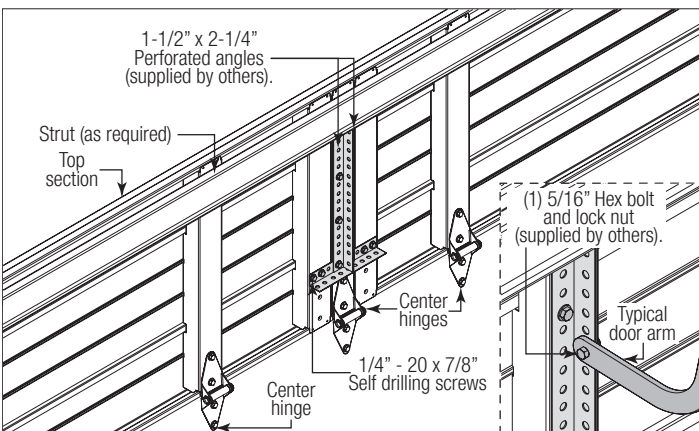
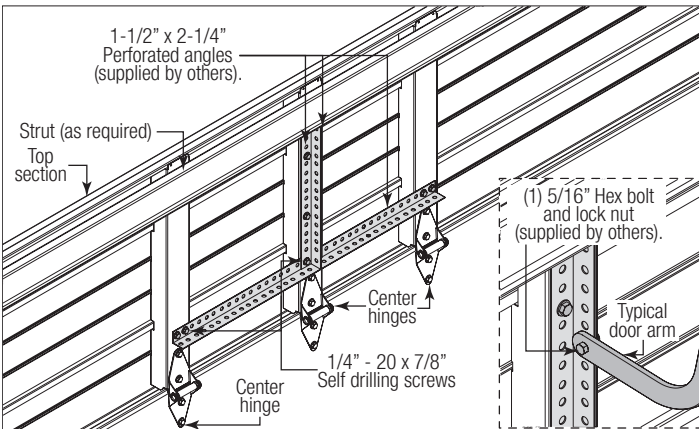
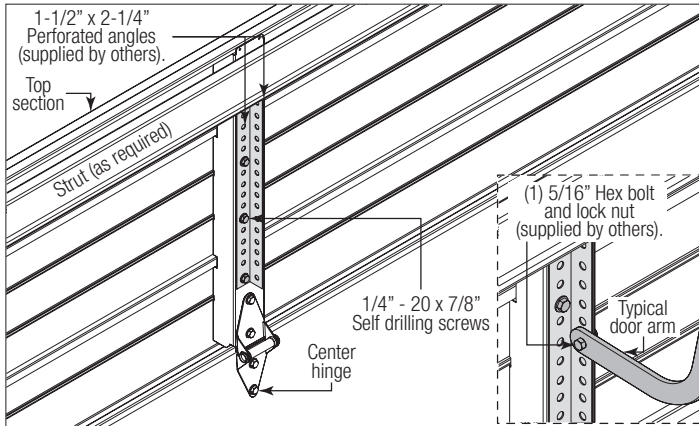

## Inside Lock

Install the inside lock on the second section of the door. Secure the lock to the section with (4) 1/4" - 20 x 11/16" self drilling screws. Square the lock assembly with the door section, and align with the square hole in the vertical track. The inside lock should be spaced approximately 1/8" away from the section edge.

**IMPORTANT:** INSIDE LOCK(S) MUST BE REMOVED OR MADE INOPERATIVE IN THE UNLOCKED POSITION IF AN OPERATOR IS INSTALLED ON THIS DOOR.

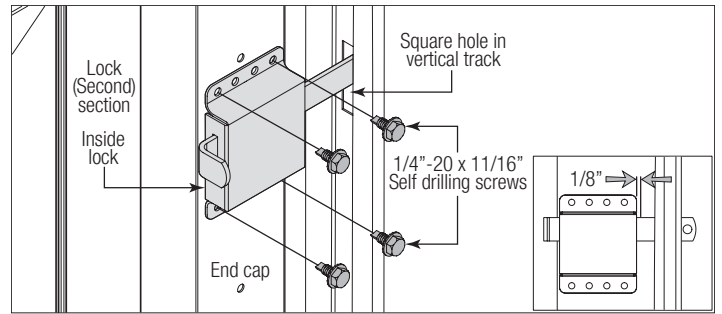

## Step Plate

**NOTE:** If you don't have this type of step plate, then skip this step.

Position your step plate on the inside surface of the bottom section over the center stile. Secure the step plate to center stile using (2) 1/4" - 20 x 7/8" self-drilling screws, as shown.

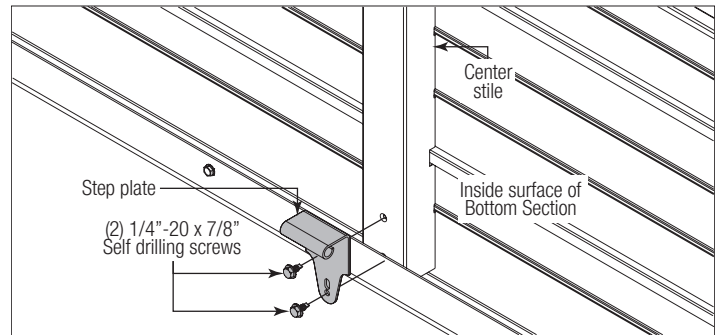

## Exhaust Port

Using the illustrations below, locate and install the exhaust port assembly to the bottom section, using (3) #10 x 1-3/4" counter sunk bolts and (3) #10 nuts, as shown.

**NOTE:** The exhaust port goes on the inside of the bottom section and can be installed into the aluminum panel or on a double wide bottom rail.

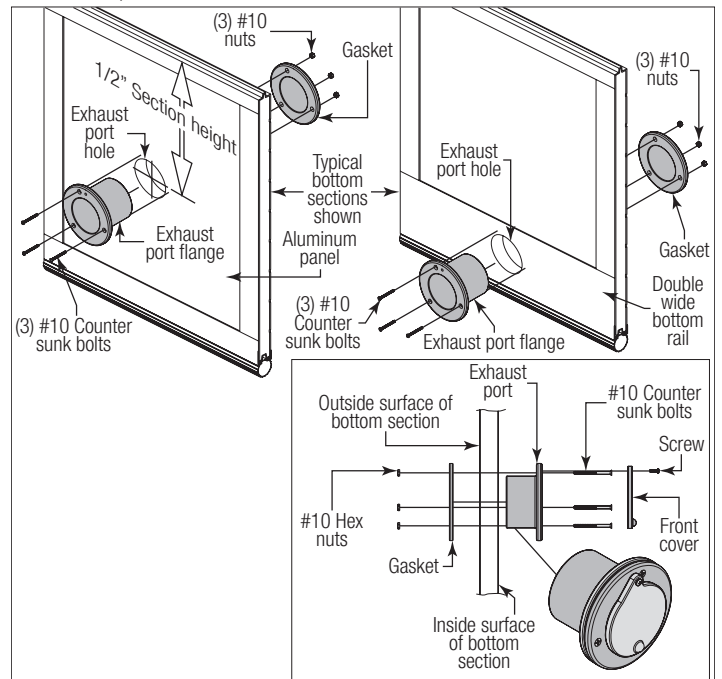



## Mini Warehouse Lock

On the inside of the door, locate the center of the end stile of the lock section. Using the lock as a template, mark drill (4) 9/32" dia. holes through the face of the door. Drill through insulation and door's face on an insulated door.

**IMPORTANT:** BE EXTREMELY CAREFUL TO KEEP DRILL STRAIGHT.

Secure the lock to the end stile using (4) 1/4" - 20 x carriage bolts, washers and 1/4 - 20 flange hex nuts, as shown.

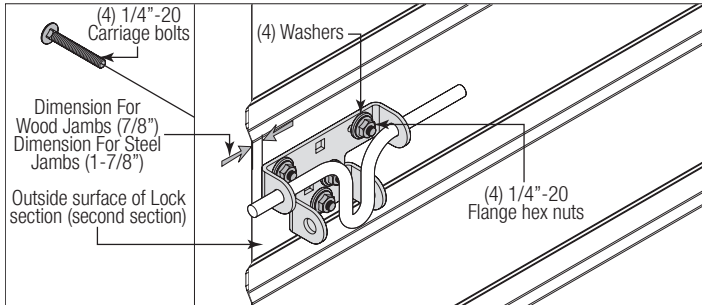

## Chain Hoist

### Chain Hoist Installation (Standard Lift Applications only!)

**NOTE:** Reference separate instructions for Chain Hoists and Jack Shaft Operators installation instruction.

Chain Hoists and Jack Shaft Operators are limited to:

- 1.) Standard Lift Doors with roof pitch track 2:12 or greater.
- 2.) High Lift track greater than or equal to 24".
- 3.) High Lift track 12" thru 24" with roof pitch track 1:12.

**IMPORTANT:** IF CHAIN HOIST OPERATED WITH AUXILIARY TROLLEY OPERATED, IT IS RECOMMENDED THAT AN OPTIONAL STRUT BE INSTALLED ON THE TOP SECTION.

### **WARNING**

**WAYNE DALTON RECOMMENDS THE USE OF A TROLLEY RAIL(S) AND AUXILIARY SHAFT FOR STANDARD OR HIGH LIFT DOORS BELOW THESE LIMITS. CABLE KEEPERS ARE RECOMMENDED FOR ALL CHAIN HOIST OR JACKSHAFTS OPERATORS. INSTALL THE CHAIN HOIST OR SPROCKET AS CLOSE TO THE END BEARING BRACKET AS POSSIBLE, TO MINIMIZE TORSION SHAFT DEFLECTION. CHAIN TENSIONERS ARE RECOMMENDED FOR DOORS OVER 144 SQ. FT. WITH JACKSHAFT OPERATORS.**

### **WARNING**

**WAYNE DALTON RECOMMENDS THE USE OF A TROLLEY RAIL(S) COUPLED TO AN AUXILIARY SHAFT THAT IS POWERED BY A SIDE MOUNT TYPE CHAIN HOIST.**

**NOTE:** 9" of extra headroom are required for these installations.

Assemble the trolley rail as per the manufactures installation instructions.

**NOTE:** Back hang the trolley using angles, center hang supports are required for doors over 14' wide and 12' high.

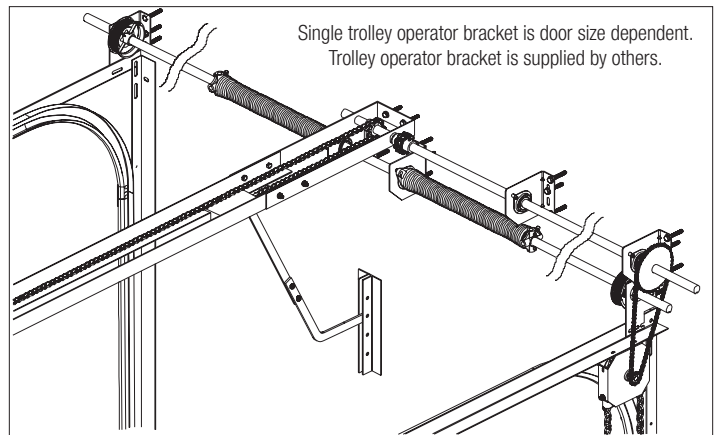
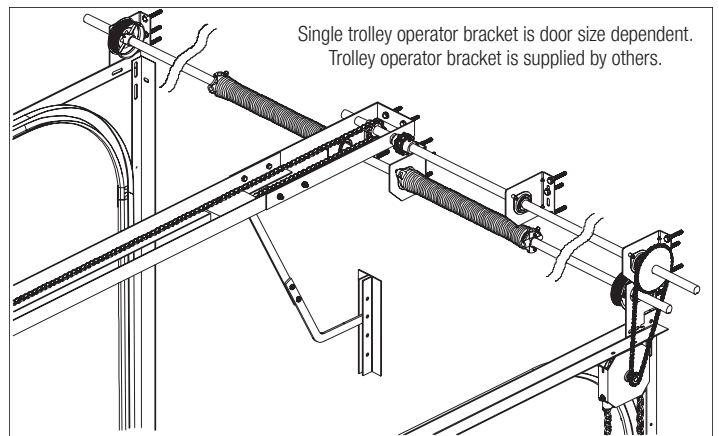
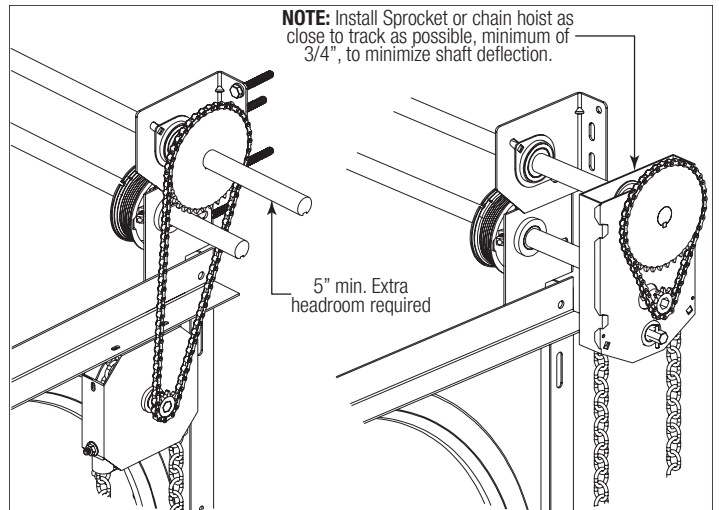
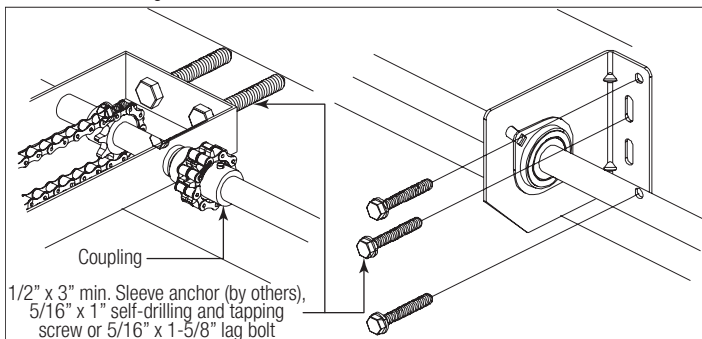

## Pusher Springs

**IMPORTANT:** RIGHT AND LEFT HAND IS ALWAYS DETERMINED FROM INSIDE THE BUILDING LOOKING OUT.

Raise the door to the open position. Mark the location of top section on top of the horizontal tracks. Close the door. Clamp pusher spring mounting bracket to the top portion of the horizontal tracks 6" to 7" away from the top section mark. Mark the two hole locations for the pusher spring mounting bolts. Remove pusher spring and drill 3/8" diameter holes through the top portion of the horizontal track. Assemble pusher spring using (2) 3/8" - 16 x 1-1/2" hex head bolts and 3/8" - 16 hex nuts. Repeat same process for the right hand side. Open door cautiously to test pusher spring installation location.

**NOTE:** The (2) 3/8" - 16 x 1-1/2" hex head bolts may extend into the horizontal track.

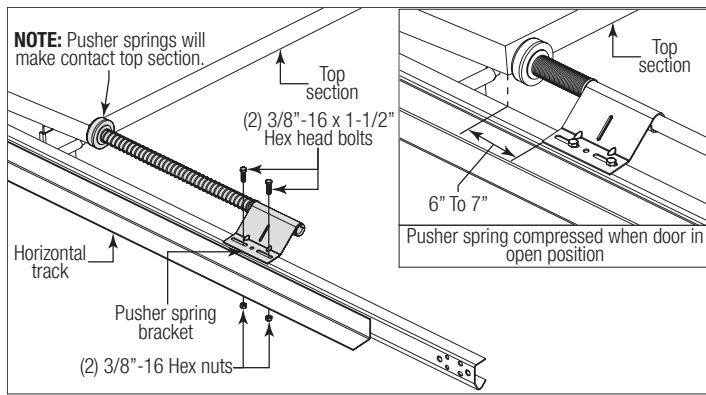

## Cleaning Your Garage Door

Like any other exterior surface, Wayne Dalton garage doors will have dirt exposure from atmospheric conditions. Ordinarily, the cleaning action of rainfall will be adequate to wash the door, or the door can be washed periodically by hosing with a garden hose and clear water (in particular) for the areas not accessible to rain. If you desire to do a more thorough cleaning, or where soil collection conditions occur, follow these simple instructions.

1. To clean acrylic glazings wash with plenty of nonabrasive soap or detergent and water. Use the bare hand to feel and dislodge any caked dirt or mud. A soft, grit-free cloth, sponge or chamois may be used to wipe the surface. Do not use hard or rough cloth that will scratch the acrylic glazing. Dry with a clean damp chamois.

2. Grease and oil may be removed with kerosene or a good grade of naphtha (No aromatic content.). Users of these solvents should become familiar with their proper ties to handle them safely.

Mild solutions of detergents or household ammonia will aid in the removal of most dirt, and the following are recommended levels:

One cup of Tide™, or other common detergents, which contain less than 0.5% phosphate, dissolved into five gallons of warm water.

**NOTE:** The use of detergents containing greater than 0.5% phosphate is not recommended for use in general cleaning of garage doors. NEVER BLEND CLEANSERS OR DETERGENTS WITH BLEACH.

3. Do not use: Window cleaning fluids, scouring compounds, gritty cloths, leaded or ethyl gasoline, or solvents such as alcohol, acetone, carbon tetrachloride, etc.

This cleaning and maintenance information is suggested in an effort to be of assistance; however, manufacturer cannot assume responsibility for results obtained which are dependent on the cleaning solution and method of application.

### FINISH AND FINISHING MAINTENANCE INSTRUCTIONS:

As with any pre-finished steel product (such as your car) general maintenance to prolong the life of the finish is recommended. On a yearly basis these procedures are to be followed for cleaning the surface of the door.

Dirt, chalk and mildew can be removed by using a mild detergent OR a diluted solution of common bleach at a concentration of one (1) cup in five (5) gallons of warm water. Rinse with clear water after washing and allow drying completely.

**CAUTION**  
NEVER MIX CLEANSERS AND BLEACH.

For added protection of a pre-painted door, the application of wax suitable for automotive use is recommended at annual intervals.

## Surface Preparation For Painting

### SURFACE PREPARATION FOR PAINTING:

Dirt, chalk and mildew can be removed by using a mild detergent OR a diluted solution of common bleach at a concentration of one (1) cup in five (5) gallons of warm water. Rinse with clear water after washing and allow drying completely.

**CAUTION**  
NEVER MIX CLEANSERS AND BLEACH.

Wax on the surface must be removed or paint peeling/flaking will result. Remove wax by wiping surface with a clean rag saturated with Xylene (Xylol). OBSERVE CAUTIONS ON SOLVENT CONTAINER.

Surface scratches which have not exposed the metal substrate can be lightly buffed or sanded with 0000 steel wool or No. 400 sand paper to create a smoother surface.

Care must be taken to not expose the substrate under the paint (see Note No. 2). Once this exposed condition exists, the likelihood for rusting is greatly increased. See the following paragraph if the metal substrate is observed.

Exposed substrate must be treated to prevent rust from forming (see Note No. 2). Sand the exposed area lightly and paint with high quality metal primer to protect from corrosion. Follow drying time on primer can label before applying topcoat.

The surface to be re-coated must not be to smooth or the repaint material will not adhere to it (See Note No. 2). It is advisable to test a representative area to evaluate adhesion. If poor adhesion is observed, the surface must be abraded by sanding or buffing using grades mentioned above. Care must be taken to not expose the substrate under the paint.

## Painting Your Garage Door

After the surface has been properly prepared it must be allowed to dry thoroughly, then coated immediately with a premium quality latex house paint. Follow the paint label directions explicitly. Oil base paint is not recommended. Please note that if substrate is exposed, painting with latex paint may cause accelerated rusting of steel.

### NOTES:

1. Re-painting of finish painted steel doors cannot be warranted as this condition is totally beyond door manufacturer's control.
2. If the steel door surface has a finish painted textured surface representing wood grain, stucco, etc., this step should not be attempted as danger of exposing substrate is greatly increased.
3. Consult a professional coatings contractor if in doubt about any of the above directions.
4. Follow directions explicitly on the paint and solvent container labels for proper applications of coatings and disposal of containers. Pay particular attention to those directions involving acceptable conditions in which to paint.

### ACRYLIC GLAZING CLEANING INSTRUCTIONS:

1. To clean acrylic glazing, wash with plenty of nonabrasive soap or detergent and water. Use the bare hand to feel and dislodge any caked dirt or mud. A soft, grit-free cloth, sponge or chamois may be used to wipe the surface. Do not use hard or rough cloth that will scratch the acrylic glazing. Dry with a clean damp chamois.
2. Grease and oil may be removed with kerosene or a good grade of naphtha (No aromatic content.). Users of these solvents should become familiar with their properties to handle them safely.
3. **Do not use:** Window cleaning fluids, scouring compounds, gritty cloths, leaded or ethyl, gasoline, or solvents such as alcohol, acetone, carbon tetrachloride, etc.

## Operation And Maintenance

### OPERATING YOUR GARAGE DOOR:

Before you begin, read all warning labels affixed to the door and the installation instructions and owner's manual. When correctly installed, your Wayne Dalton door will operate smoothly. Always operate your door with controlled movements. Do not slam your door or throw your door into the open position, this may cause damage to the door or its components. If your door has an electric opener, refer to the owner's manual to disconnect the opener before performing manual door operation below.

### MANUAL DOOR OPERATION:

For additional information on manual garage door operations go to [www.dasma.com](http://www.dasma.com) and reference TDS 165.

**IMPORTANT:** DO NOT PLACE FINGERS OR HANDS INTO SECTION JOINTS WHEN OPENING AND/OR CLOSING A DOOR. ALWAYS USE LIFT HANDLES / SUITABLE GRIPPING POINTS WHEN OPERATING THE DOOR MANUALLY.

Opening a Door: Make sure the lock(s) are in the unlocked position. Lift the door by using the lift handles / suitable gripping points only. Door should open with little resistance.

Closing a Door: From inside the garage, pull door downward using lift handles / gripping points only or a high friction area only. If you are unable to reach the lift handles/ suitable gripping points only, use pull down rope affixed to the side of door. Door should close completely with little resistance.

### USING AN ELECTRIC OPERATOR:

**IMPORTANT:** PULL DOWN ROPES MUST BE REMOVED AND LOCKS MUST BE REMOVED OR MADE INOPERATIVE IN THE UNLOCKED POSITION.

When connecting a drawbar (trolley type) garage door operator to this door, a drawbar operator and or drawbar operator bracket must be securely attached to the top section of the door, along with any struts provided with the door. Always use the drawbar operator and or drawbar operator bracket supplied with the door. To avoid possible damage to your door, Wayne Dalton recommends reinforcing the top section with a strut (may or may not be supplied). The installation of the drawbar operator must be according to manufacturer's instructions and force settings must be adjusted properly. Refer to the owner's manual supplied with your drawbar operator for complete details on installation, operation, maintenance and testing of the operator.

### MAINTAINING YOUR GARAGE DOOR:

Before you begin, read all warning labels affixed to the door and the installation instructions and owner's manual. Perform routine maintenance steps once a month, and have the door professionally inspected once a year. Review your Installation Instructions and Owner's Manual for the garage door. These instructions are available at no charge from Wayne Dalton, a division of Overhead Door Corporation, P.O. Box 67, Mt. Hope, OH., 44660, or at [www.Wayne-Dalton.com](http://www.Wayne-Dalton.com). For additional information on garage door/operator maintenance go to [www.dasma.com](http://www.dasma.com) and reference TDS 151, 167 and 179.

### MONTHLY INSPECTIONS:

**1. Visual Inspection:** Closely inspect jambs, header and mounting surface. Any wood found not to be structurally sound must be replaced. Inspect the springs, counterbalance lift cables, track rollers, pulleys, rear back hangs and other door hardware for signs of worn or broken parts. Tighten any loose screws and/or bolts. Check exterior surface of the door sections for any minor cracks. Verify door has not shifted right or left in the opening. If you suspect problems, have a trained door system technician make the repairs.

## **WARNING**

**GARAGE DOOR SPRINGS, COUNTERBALANCE LIFT CABLES, BRACKETS, AND OTHER HARDWARE ATTACHED TO THE SPRINGS ARE UNDER EXTREME TENSION, AND IF HANDLED IMPROPERLY, CAN CAUSE SEVERE OR FATAL INJURY. ONLY A TRAINED DOOR SYSTEMS TECHNICIAN SHOULD ADJUST THEM, BY CAREFULLY FOLLOWING THE MANUFACTURER'S INSTRUCTIONS.**

## **WARNING**

**NEVER REMOVE, ADJUST, OR LOOSEN THE BOLTS, SCREWS AND/OR LAG SCREWS ON THE COUNTERBALANCE (END OR CENTER BEARING BRACKETS) SYSTEM OR BOTTOM CORNER BRACKETS OF THE DOOR. THESE BRACKETS ARE CONNECTED TO THE SPRING(S) AND ARE UNDER EXTREME TENSION. TO AVOID POSSIBLE SEVERE OR FATAL INJURY, HAVE ANY SUCH WORK PERFORMED BY A TRAINED DOOR SYSTEMS TECHNICIAN USING PROPER TOOLS AND INSTRUCTIONS**

**Torsion Springs:** The torsion springs (located above the door) should only be adjusted by a trained door systems technician. DO NOT attempt to repair or adjust torsion springs yourself.

**Extension Springs:** A restraining cable or other device should be installed on the extension spring (located above the horizontal tracks) to help contain the spring if it breaks.

**2. Door Balance:** Periodically test the balance of your door. If you have a garage door drawbar operator, use the release mechanism so you can operate the door by hand when doing this test. Start with the door in the fully closed position. Lift the door to check its balance. Adjust Extension spring(s), if door lifts by itself (hard to pull down) or if door is difficult to lift (easy to pull down). DO NOT attempt to repair or adjust Torsion Springs yourself. To adjust Extension spring(s), refer to your installation instructions and owner's manual. If in question about any of the procedures, do not perform the work. Instead, have it adjusted by a trained door systems technician.

**3. Lubrication:** The door should open and close smoothly. Ensure the door track rollers are rotating freely when opening and closing the door. If track rollers do not rotate freely, clean the door tracks, removing dirt and any foreign substances. Clean and lubricate (use a non-silicon based lubricant) graduated end hinges, center hinge(s), steel track rollers, bearings and torsion spring(s) (torsion spring coil surfaces). DO NOT lubricate plastic idler bearings, nylon track rollers, door track. DO NOT oil a cylinder lock, if actuation is difficult use a graphite dust to lubricate.



**Commercial Sectional  
Models 216, 220, 2415, 2411, C-20, C-24, and C-2400  
Limited Warranty**

Wayne Dalton, a division of Overhead Door Corporation ("Seller") warrants to the original purchaser of the Model 216, 220, 2415, 2411, C-20, C-24, or C-2400 Commercial Sectional Door (insulated or non-insulated) ("Product"), subject to all of the terms and conditions hereof, that the Product and all components thereof will be free from defects in materials and workmanship for the following period(s) of time, measured from the date of installation:

- **ONE (1) YEAR** against defects in materials and workmanship

Seller's obligation under this warranty is specifically limited to repairing or replacing, at its option, any part which is determined by Seller to be defective during the applicable warranty period. Any labor charges are excluded and will be the responsibility of the purchaser.

This warranty is made to the original purchaser of the Product only, and is not transferable or assignable. This warranty does not apply to any unauthorized alteration or repair of the Product, or to any Product or component which has been damaged or deteriorated due to misuse, neglect, accident, failure to provide necessary maintenance, normal wear and tear, acts of God, or any other cause beyond the reasonable control of Seller, or as a result of having been exposed to toxic or abrasive environments, including blowing sand, salt water, salt spray and toxic chemicals and fumes.

THIS WARRANTY IS EXCLUSIVE AND IN LIEU OF ANY OTHER WARRANTIES, EITHER EXPRESS OR IMPLIED, INCLUDING BUT NOT LIMITED TO ANY IMPLIED WARRANTY OF MERCHANTABILITY OR FITNESS FOR A PARTICULAR PURPOSE.

IN NO EVENT SHALL SELLER BE RESPONSIBLE FOR, OR LIABLE TO ANYONE FOR, SPECIAL, INDIRECT, COLLATERAL, PUNITIVE, INCIDENTAL OR CONSEQUENTIAL DAMAGES, even if Seller has been advised of the possibility of such damages. Such excluded damages include, but are not limited to, loss of use, cost of any substitute product, or other similar indirect financial loss.

Claims under this warranty must be made promptly after discovery, within the applicable warranty period, and in writing to the authorized dealer or installer whose name and address appear below. The purchaser must allow Seller a reasonable opportunity to inspect any Product claimed to be defective prior to removal or any alteration of its condition. Proof of the purchase and/or installation date, and identification as the original purchaser, may be required.

SELLER: \_\_\_\_\_

SELLER'S ADDRESS: \_\_\_\_\_

\_\_\_\_\_

---

Thank you for your purchase.

---

If you need assistance, please call 1-866-569-3799 (press Option 1) and follow the prompts to contact a customer service representative. They will be happy to handle any questions that you may have.

---

After installation is complete, leave this Installation Instructions And Owner's Manual with the homeowner, or fasten it near garage door for easy reference.