

# Models 8000 / 8100 / 8200

TORQUEMASTER® PLUS

RESIDENTIAL  
STANDARD LIFT  
WINDLOAD

INSTALLATION INSTRUCTIONS AND OWNER'S  
MANUAL

## Table Of Contents

<b>Pre-Installation</b>	<b>2</b>
Important Safety Instructions	2
Removing an Existing Door and Preparing the Opening	2
Package Contents	3
Door Section Identification	4
Tools Required	4
<b>Breakdown Of Parts</b>	<b>5</b>
<b>Door Installation Instructions</b>	<b>6</b>
<b>Counterbalance Installation Instructions</b>	<b>12</b>
<b>Optional Installation</b>	<b>18</b>
TorqueMaster® Plus Reset Instructions	18
Inside Lock	18
Pull Down Rope	18
<b>Maintenance</b>	<b>20</b>
Cleaning Your Garage Door	20
Painting Your Garage Door	20
Maintaining The Finish On Your Garage Door	20
Operation And Maintenance	20
<b>Warranty</b>	<b>22</b>

### **PLEASE DO NOT RETURN THIS PRODUCT TO THE STORE**

If you need assistance, please call 1-866-569-3799 (press Option 1) and follow the prompts to contact a customer service representative. They will be happy to handle any questions that you may have.

### **IMPORTANT NOTICES!**

To avoid possible injury, read and fully understand the enclosed instructions carefully before installing and operating the garage door. Pay close attention to all warnings and notes. After installation is complete, fasten this manual near garage door for easy reference.

This Installation document is available at no charge from:

- Your local Wayne Dalton Sales Center, or
- Online at [www.Wayne-Dalton.com](http://www.Wayne-Dalton.com), or
- By mailing to: Wayne Dalton, a division of Overhead Door Corporation, P.O. Box 67, Mt. Hope, OH., 44660

## Important Safety Instructions

### DEFINITION OF KEY WORDS USED IN THIS MANUAL:

#### **WARNING**

INDICATES A POTENTIALLY HAZARDOUS SITUATION WHICH; IF NOT AVOIDED, COULD RESULT IN SEVERE OR FATAL INJURY.

#### **CAUTION**

PROPERTY DAMAGE OR INJURY CAN RESULT FROM FAILURE TO FOLLOW INSTRUCTIONS.

**IMPORTANT:** REQUIRED STEP FOR SAFE AND PROPER DOOR OPERATION.

**NOTE:** Information assuring proper installation of the door.

**READ THESE INSTRUCTIONS CAREFULLY BEFORE ATTEMPTING INSTALLATION. IF IN QUESTION ABOUT ANY OF THE PROCEDURES, DO NOT PERFORM THE WORK. INSTEAD, HAVE A TRAINED DOOR SYSTEMS TECHNICIAN DO THE INSTALLATION OR REPAIRS.**

1. READ AND FOLLOW ALL INSTALLATION INSTRUCTIONS.
2. Wear protective gloves during installation to avoid possible cuts from sharp metal edges.
3. It is always recommended to wear eye protection when using tools, otherwise eye injury could result.
4. Avoid installing your new door on windy days. Door could fall during the installation causing severe or fatal injury.
5. Doors 12'-0" wide and over should be installed by two persons, to avoid possible injury.
6. Operate door only when it is properly adjusted and free from obstructions.
7. If a door becomes hard to operate, inoperative or is damaged, immediately have necessary adjustments and/ or repairs made by a trained door system technician using proper tools and instructions.
8. DO NOT stand or walk under a moving door, or permit anybody to stand or walk under an electrically operated door.
9. DO NOT place fingers or hands into open section joints when closing a door. Use lift handles/ gripping points when operating door manually.
10. DO NOT permit children to operate garage door or door controls. Severe or fatal injury could result should the child become entrapped between the door and the floor.
11. Due to constant extreme spring tension, do not attempt any adjustment, repair or alteration to any part of the door, especially to springs, spring brackets, bottom corner brackets, fasteners, counterbalance lift cables or supports. To avoid possible severe or fatal injury, have any such work performed by a trained door systems technician using proper tools and instructions.
12. On electrically operated doors, pull down ropes must be removed and locks must be removed or made inoperative in the open (unlocked) position.
13. Top section of door may need to be reinforced when attaching an electric opener. Check door and/ or opener manufacturer's instructions.
14. Visually inspect door and hardware monthly for worn and or broken parts. Check to ensure door operates freely.
15. Test electric opener's safety features monthly, following opener manufacturer's instructions.
16. NEVER hang tools, bicycles, hoses, clothing or anything else from horizontal tracks. Track systems are not intended or designed to support extra weight.
17. This door may not meet the building code wind load requirements in your area. For your safety, you will need to check with your local building official for wind load code requirements and building permit information.
18. For windloaded doors, the wind performance is achieved via the entire door system and component substitution is not authorized without express permission by Wayne Dalton.

**NOTE:** It is recommended that 5/16" lag screws are pilot drilled using a 3/16" drill bit, prior to fastening.





#### **CAUTION**

IF ANY PART OF THE DOOR IS TO BE INSTALLED ONTO PRESERVATIVE-TREATED WOOD, PTFE-COATED OR STAINLESS STEEL FASTENERS MUST BE OBTAINED AND USED. REPLACEMENT FASTENERS MUST BE OF AT LEAST EQUAL STRENGTH AND SIZE AS ORIGINAL FASTENERS. IF THE ORIGINAL FASTENER WAS RED-HEAD, THE REPLACEMENT FASTENER MUST BE RED-HEAD ALSO. CONTACT WAYNE DALTON FOR FASTENER STRENGTH VALUES IF NEEDED.

#### **WARNING**

**IMPACT GUNS ARE NOT RECOMMENDED. WHEN INSTALLING 5/16" LAG SCREWS USING AN ELECTRIC DRILL/ DRIVER, THE DRILL/ DRIVERS CLUTCH MUST BE SET TO DELIVER NO MORE THAN 200 IN-LBS OF TORQUE. FASTENER FAILURE COULD OCCUR AT HIGHER SETTINGS.**

**IMPORTANT:** RIGHT AND LEFT HAND IS DETERMINED INSIDE THE BUILDING LOOKING OUT.

Potential Hazard	Effect	Prevention
 <p>Moving door</p>	 <b>WARNING</b> Could result in Death or Serious Injury	Keep people clear of opening while Door is moving.  Do <b>NOT</b> allow children to play with the Door Opener.  Do <b>NOT</b> operate a Door that jams or one that has a broken spring.
 <p>High tension spring</p>	 <b>WARNING</b> Could result in Death or Serious Injury	Do <b>NOT</b> try to remove, install, repair or adjust springs or anything to which door spring parts are fastened, such as, wood blocks, steel brackets, cables or other like items.  Installations, repairs and adjustments must be done by a trained door system technician using proper tools and instructions.

## Removing an Existing Door and Preparing the Opening

**IMPORTANT:** COUNTERBALANCE SPRING TENSION MUST ALWAYS BE RELEASED BEFORE ANY ATTEMPT IS MADE TO START REMOVING AN EXISTING DOOR.

#### **WARNING**

**A POWERFUL SPRING RELEASING ITS ENERGY SUDDENLY CAN CAUSE SEVERE OR FATAL INJURY. TO AVOID INJURY, HAVE A TRAINED DOOR SYSTEMS TECHNICIAN, USING PROPER TOOLS AND INSTRUCTIONS, RELEASE THE SPRING TENSION.**

To avoid possible injury and to insure proper installation, it's highly recommended that you read and fully understand the complete instructions on removing an Existing Door & Preparing the Opening. These are available for download at [www.Wayne-Dalton.com](http://www.Wayne-Dalton.com) or at your local Wayne Dalton Sales Center.

**IMPORTANT:** IF YOU JUST REMOVED YOUR EXISTING DOOR OR YOU ARE INSTALLING A NEW DOOR, COMPLETE ALL STEPS IN PREPARING THE OPENING.

To ensure secure mounting of track brackets, side and center brackets, or steel angles to new or retro-fit construction, it is recommended to follow the procedures outlined in DASMA technical data sheets #156, #161 and #164 at [www.dasma.com](http://www.dasma.com).

The inside perimeter of your garage door opening should be framed with wood jamb and header material. The jambs and header must be securely fastened to sound framing members. It is recommended that 2" x 6" lumber be used. The jambs must be plumb and the header level. The jambs should extend a minimum of 12" (305 mm) above the top of the opening for TorqueMaster® counterbalance systems. For low headroom applications, the jambs should extend to the ceiling height. Minimum side clearance required, from the opening to the wall, is 3-1/2" (89 mm).

**IMPORTANT:** CLOSELY INSPECT JAMBS, HEADER AND MOUNTING SURFACE. ANY WOOD FOUND NOT TO BE SOUND, MUST BE REPLACED.

For TorqueMaster® counterbalance systems, a suitable mounting surface (2" x 6") must be firmly attached to the wall, above the header at the center of the opening.

**NOTE:** Drill a 3/16" pilot hole in the mounting surface to avoid splitting the lumber. Do not attach the mounting surface with nails.

**WEATHERSTRIPS (MAY NOT BE INCLUDED):**

Depending on the size of your door, you may have to cut or trim the weatherstrips (if necessary) to properly fit into the header and jambs.

**NOTE:** If nailing product at 40°F or below, pre-drilling is required.

**NOTE:** Do not permanently attach weatherstrips to the header and jambs at this time.

**FOR QUICK INSTALL TRACK:** For the header, align the weatherstrip with the inside edge of the header and temporarily secure it to the header with equally spaced nails. Starting at either side of the jamb, fit the weatherstrip up tight against the temporarily attached weatherstrip in the header and flush with the inside edge of the jamb. Temporarily secure the weatherstrip with equally spaced nails. Repeat for other side. This will keep the bottom section from falling out of the opening during installation. Equally space nails approximately 12" to 18" apart.

**FOR FULLY ADJUSTABLE TRACK:** For the header, align the weatherstrip 1/8" to 1/4" inside the header edge, and temporarily secure it to the header with equally spaced nails. Starting at either side of the jamb, fit the weatherstrip up tight against the temporarily attached weatherstrip in the header and 1/8" to 1/4" inside the jamb edge. Temporarily secure the weatherstrip with equally spaced nails. Repeat for other side. This will keep the bottom section from falling out of the opening during installation. Equally space nails approximately 12" to 18" apart.

**HEADROOM REQUIREMENT:** Headroom is defined as the space needed above the top of the door for tracks, springs, etc. to allow the door to open properly. If the door is to be motor operated, 2-1/2" (64 mm) of additional headroom is required.

**NOTE:** 6" low headroom conversion kit is available for 12" radius only. Contact your local Wayne Dalton dealer.

**BACKROOM REQUIREMENT:** Backroom is defined as the distance needed from the opening back into the garage to allow the door to open fully.

**BACKROOM REQUIREMENTS**

DOOR HEIGHT	TRACK	MANUAL LIFT	MOTOR OPERATED
6'5" to 7'0"	12", 15" Radius	98" (2489 mm)	125" (3175 mm)
7'1" to 8'0"	12", 15" Radius	110" (2794 mm)	137" (3480 mm)

**HEADROOM REQUIREMENTS**

TRACK TYPE	SPACE NEEDED
15" Radius track	13-1/2" (343 mm)
12" Radius track	11" (279 mm)
6" LHR KIT	6" (152 mm)

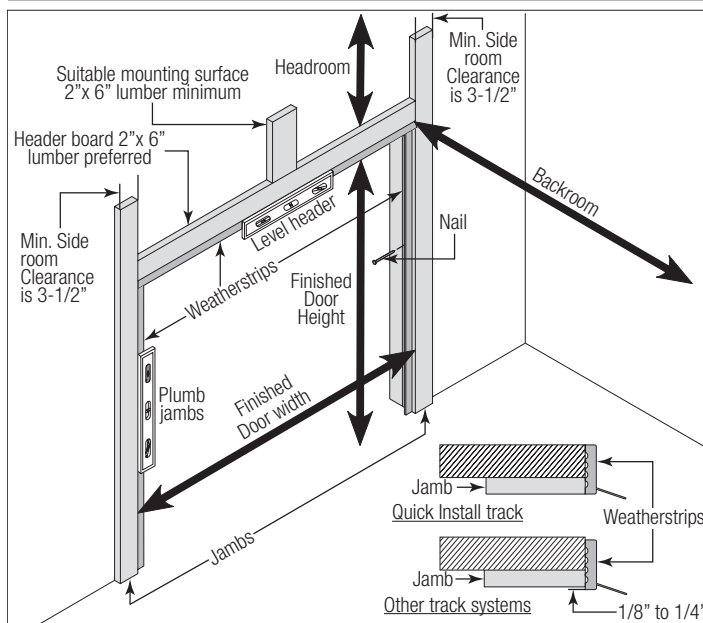

**Package Contents**

**NOTE:** Depending on the door model, some parts listed will not be supplied if not required. Rear Back Hangs may not be included with your door.

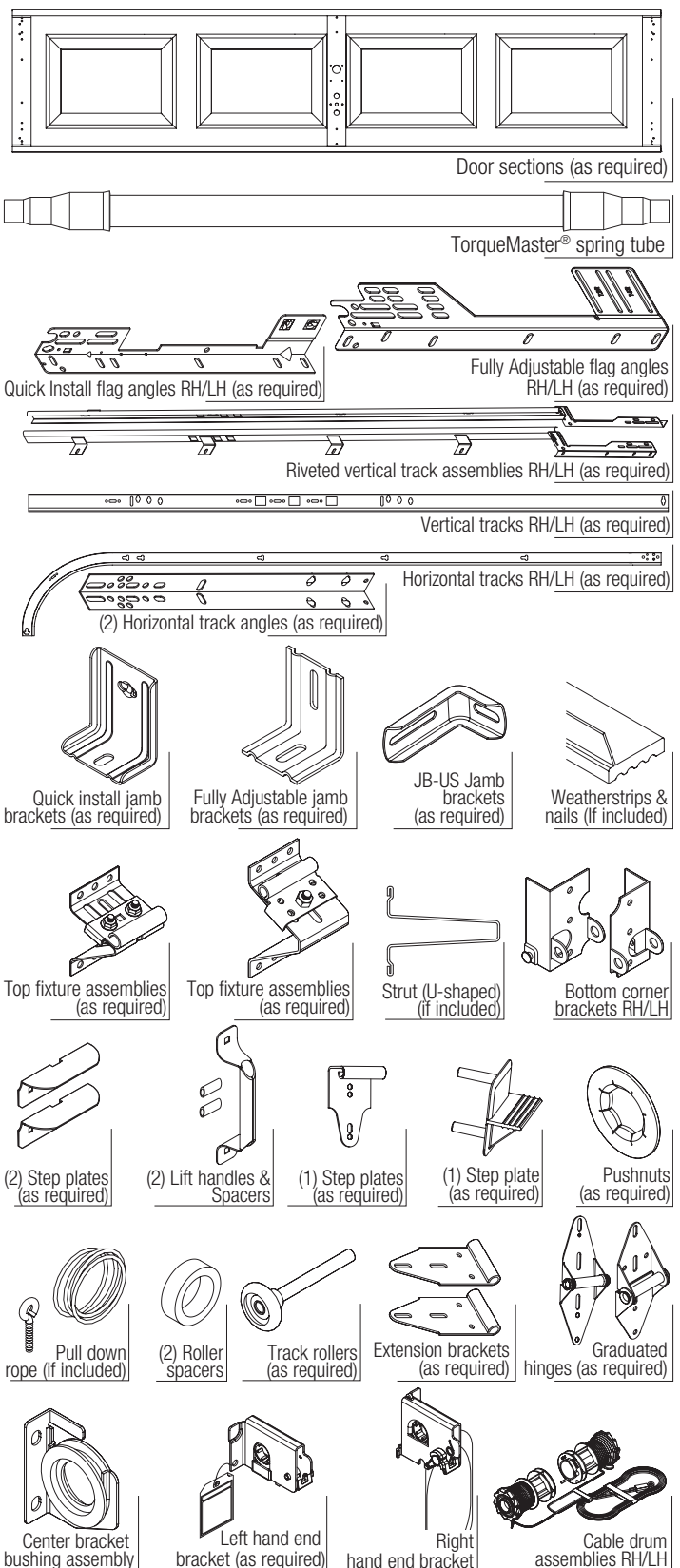

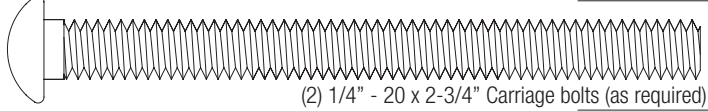
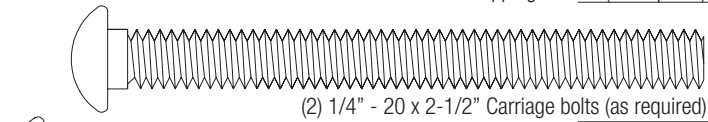
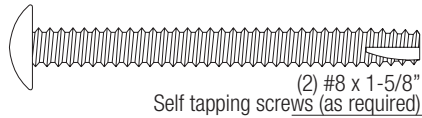
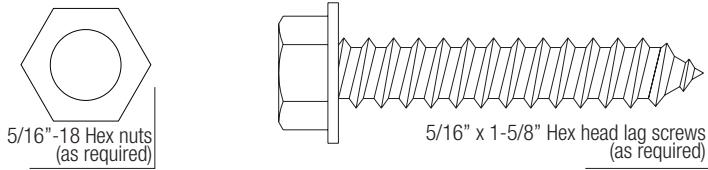
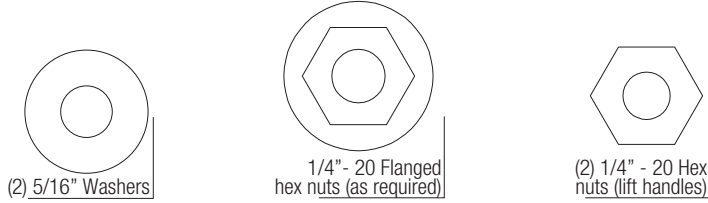
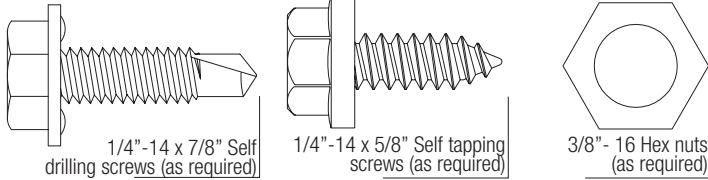
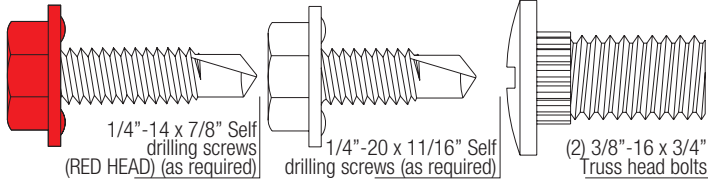
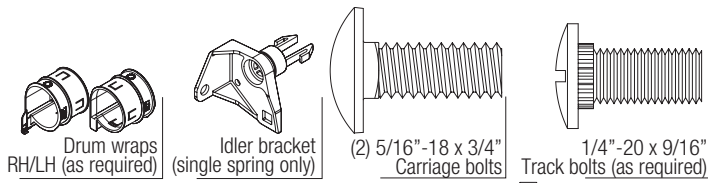

Unless your door is five sections in height, you will not receive an Intermediate II section.  
 The **BOTTOM SECTION** can be identified by the factory attached bottom astragal, the factory attached bottom corner brackets, and by the bottom corner bracket warning labels on each end stile.

The **INTERMEDIATE I SECTION** may have a warning label attached to either right or left hand end stile of the section. This section is always the 3rd section from the bottom of the door.

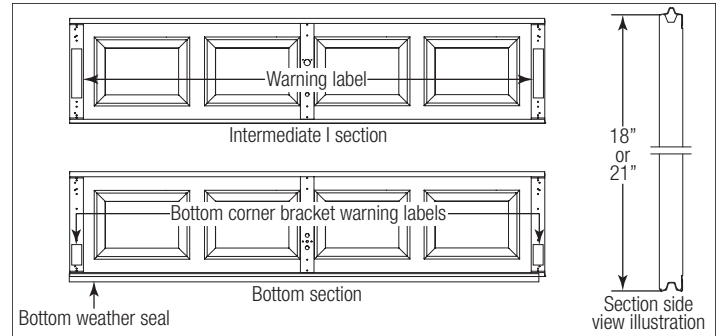

## Tools Required

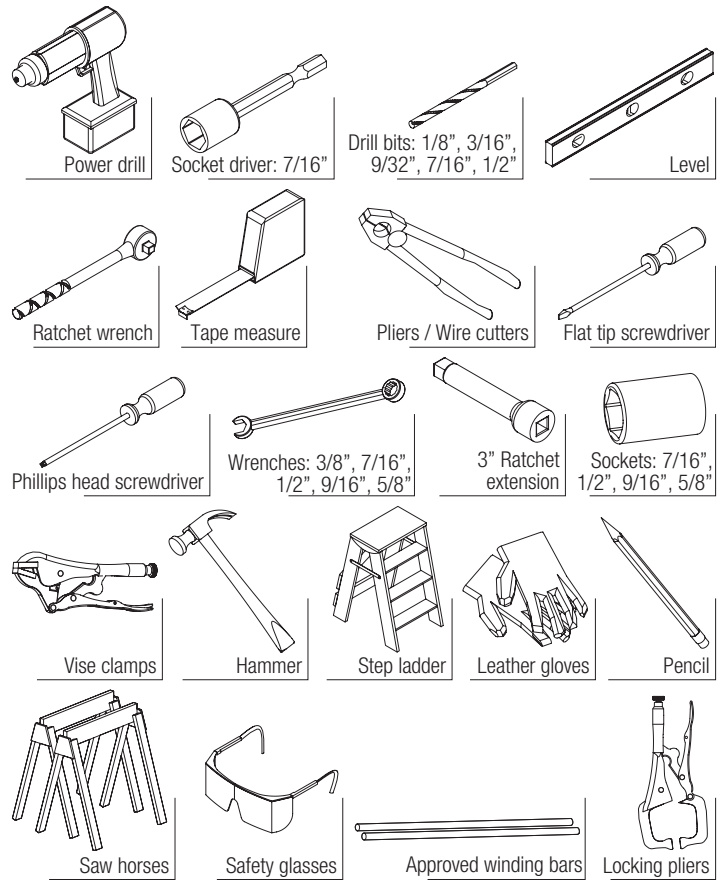

## Door Section Identification

Door Section Identification					
Door Height	Bottom	Lock (second)	Intermediate I (third)	Intermediate II (fourth)	Top
6'0"	18"	18"	18"	NA	18"
6'3"	21"	18"	18"	NA	18"
6'6"	21"	18"	18"	NA	21"
6'9"	21"	21"	21"	NA	18"
7'0"	21"	21"	21"	NA	21"
7'6"	18"	18"	18"	18"	18"
7'9"	21"	18"	18"	18"	18"
8'0"	21"	18"	18"	18"	21"

When installing your door you must use sections of the appropriate height in the right stacking order. What section heights you need to use in what order depends on the height of your door.

# BREAKDOWN OF PARTS

**NOTE:** The illustrations shown on this page are general representations of the door parts. Each specific door models may have unique variations.

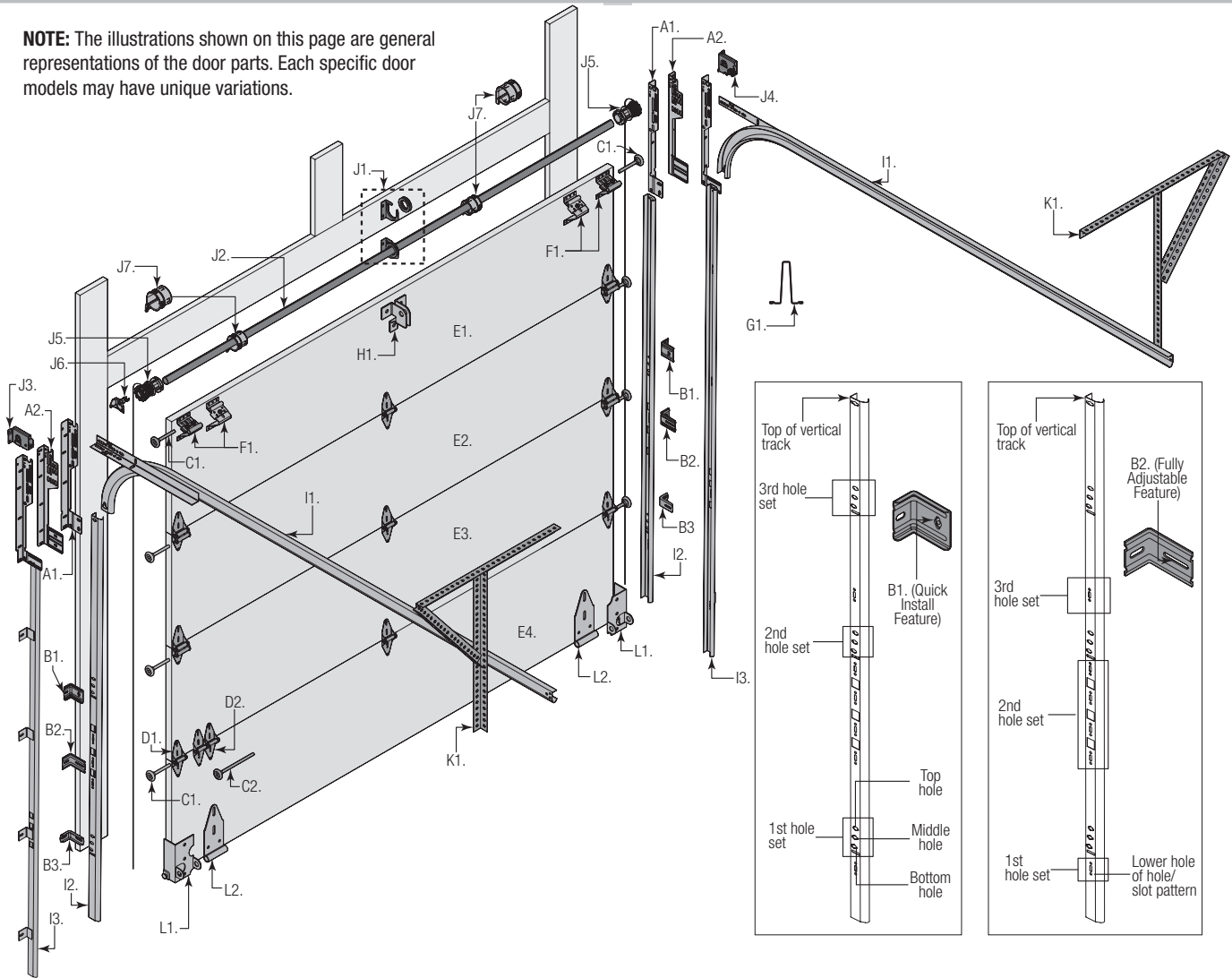

**A. FLAG ANGLES (AS REQUIRED):**

- A1. Quick Install (Q.I.) Flag Angles
- A2. Fully Adjustable (F.A.) Flag Angles

**B. JAMB BRACKETS (AS REQUIRED):**

- B1. Quick Install (Q.I.) Jamb Brackets
- B2. Fully Adjustable (F.A.) Jamb Brackets
- B3. Windload Jamb Brackets

**C. TRACK ROLLERS (AS REQUIRED):**

- C1. Short Stem Track Rollers
- C2. Long Stem Track Rollers

**D. GRADUATED END HINGES (AS REQUIRED):**

- D1. Single Graduated End Hinges (S.E.H.), Industry Standard
- D2. Double Graduated End Hinges (D.E.H.), Industry Standard

**E. STACKED SECTIONS:**

- E1. Top Section
- E2. Intermediate(s) Section
- E3. Lock Section
- E4. Bottom Section

**F. TOP FIXTURES (AS REQUIRED):**

- F1. Top Fixture Assemblies

**G. STRUT(S) (AS REQUIRED):**

- G1. Strut (U - shaped)

**H. DRAWBAR OPERATOR BRACKET (FOR TROLLEY OPERATED DOORS):**

- H1. Drawbar Operator Bracket (Supplied By Others)

**I. TRACKS (AS REQUIRED):**

- I1. Left Hand And Right Hand Horizontal Track Assemblies
- I2. Left Hand And Right Hand Vertical Tracks
- I3. Left Hand And Right Hand Riveted Vertical Track Assemblies

**J. TORQUEMASTER PLUS® SPRING ASSEMBLY:**

- J1. Center Bracket Bushing Assembly
- J2. TorqueMaster® Spring Tube (Single Or Double Springs)
- J3. Left Hand End Bracket (Double Springs Only)
- J4. Right Hand End Bracket (Disconnect Cable Guide)
- J5. Left Hand And Right Hand Cable Drum Assemblies
- J6. Idler bracket (Single Spring Only)
- J7. Left Hand And Right Hand Drum Wraps (Optional)

**K. REAR BACK HANGS:**

- K1. Left Hand And Right Hand Rear Back Hang Assemblies

**L. BOTTOM CORNER BRACKETS (AS REQUIRED):**

- L1. Left Hand And Right Hand Bottom Corner Brackets
- L2. Left Hand And Right Hand Extension Brackets

# DOOR INSTALLATION INSTRUCTIONS

Before installing your door, be certain that you have read and followed all of the instructions covered in the pre-installation section of this manual. Failure to do so may result in an improperly installed door.

**NOTE:** Reference TDS 160 for general garage door terminology at [www.dasma.com](http://www.dasma.com).

**IMPORTANT:** IF THE DOOR WILL BE EXPOSED TO A SIGNIFICANT AMOUNT OF ROAD SALT, PAINT THE BARE GALVANIZED BOTTOM WEATHER STEEL RETAINER TO INHIBIT RUSTING.

## 1 Attaching Flag Angles and Jamb Brackets To Vertical Tracks

**NOTE:** If you have Riveted Track or Angle Mount Track, skip this step.

**FOR DOORS WITH QUICK INSTALL TRACK:** Place the lower Quick Install tab of the left hand flag angle in the Quick Install feature of the left hand vertical track. Give the flag angle 1/4 turn to lock in place. Measure the length of the vertical tracks. Using the jamb bracket schedule, determine the placement of the jamb brackets for your door height and track length. To install the jamb brackets, align the Quick Install tab on the Quick Install jamb bracket with the Quick Install feature in the vertical track and turn the bracket perpendicular to the track so the mounting flange is toward the back (flat) leg of the track. Repeat the same process for right hand side.

JAMB BRACKET SCHEDULE							
DOOR HEIGHT	TRACK LENGTH	1ST SET		2ND SET		3RD SET	
6'0"	64" (1626 mm)	9	M	11	M	NA	
6'3"	67" (1702 mm)	9	B	11	M	NA	
6'6"	70" (1778 mm)	9	M	10	B	NA	
6'9"	73" (1854 mm)	9	M	10	B	NA	
7'0"	76" (1930 mm)	9	M	10	B	NA	
7'6"	82" (2083 mm)	9	T	10	M	11	M
7'9"	85" (2159 mm)	9	T	10	M	11	M
8'0"	88"	9	T	10	M	11	M

B= BOTTOM HOLE, M= MIDDLE HOLE, T= TOP HOLE

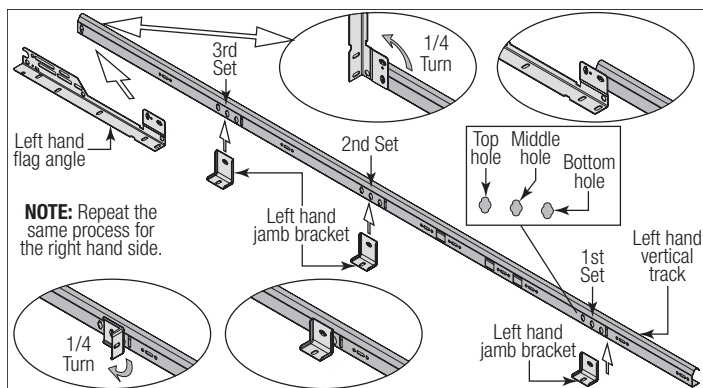

**FOR DOORS WITH FULLY ADJUSTABLE TRACK:** Hand tighten the left hand flag angle to the left hand vertical track using (2) 1/4" - 20 x 9/16" track bolts and (2) 1/4" - 20 flange hex nuts.

**NOTE:** The bottom jamb bracket is always the shortest bracket, while the center jamb bracket is the next tallest. If three jamb brackets per side are included with your door, you will have received a top jamb bracket, which is the tallest.

To attach the bottom jamb bracket, locate lower hole of the hole/ slot pattern of the 1st hole set on the vertical track. Align the slot in the jamb bracket with the lower hole of the hole/ slot pattern. Hand tighten jamb bracket using (1) 1/4" - 20 x 9/16" track bolt and (1) 1/4" - 20

flange hex nut.

Place the center jamb bracket over the lower hole of the hole/ slot pattern that is centered between the bottom jamb bracket and flag angle of the 2nd hole set. Hand tighten jamb bracket using (1) 1/4" - 20 x 9/16" track bolt and (1) 1/4" - 20 flange hex nut.

If a top jamb bracket was included, hand tighten it to vertical track using the lower hole of the hole/ slot pattern in the 3rd hole set and (1) 1/4" - 20 x 9/16" track bolt and (1) 1/4" - 20 flange hex nut.

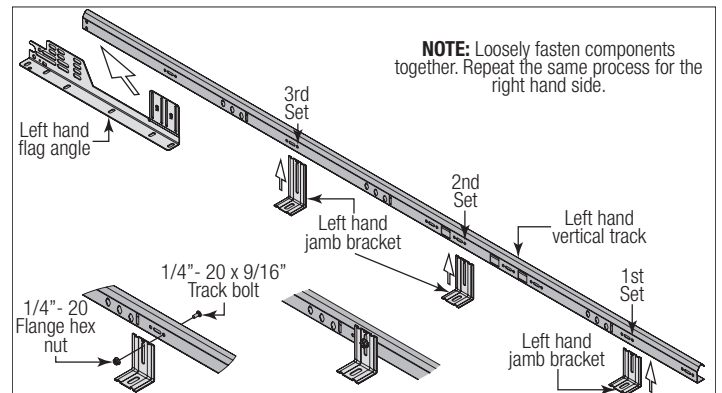
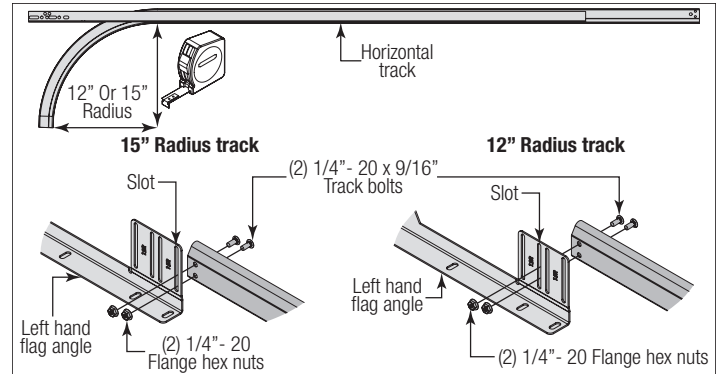

## 2 Attaching Horizontal Track Angles

**NOTE:** For larger doors, a full length horizontal track angle may not already be spot welded to the horizontal track. If the horizontal track angle is not welded, the horizontal track angle will be installed, as shown.

Position the left hand horizontal track angle, as shown. Place the Quick Install tabs of the horizontal track angle in the key slot of the left hand horizontal track. Using a hammer, tap the horizontal track angle towards the curved end of the track until the alignment hole in the track and angle are aligned. Repeat for other side. Set tracks aside.

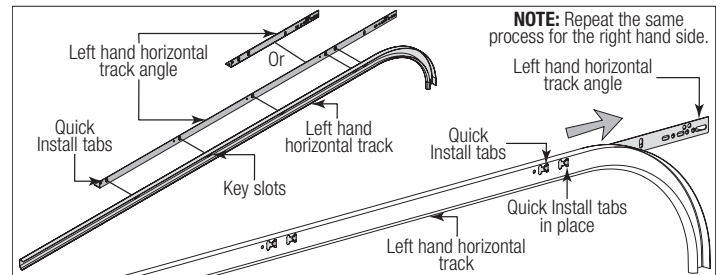

## 3 Attaching (WL) Jamb Brackets To Vertical Tracks

**NOTE:** Windload specification 0356 only uses the Quick Install (Q.I.) jamb bracket schedule.

**NOTE:** Reference Step Quick Install Flag Angles (Q.I.) or Step Fully Adjustable Flag Angles (F.A.T.), to determine which type of track you have.

Measure the length of the vertical tracks. Using the Jamb Bracket Schedule (shown on the Windload Specification Sheet), determine the placement of the windload jamb brackets for your door height. Loosely fasten the jamb bracket to the vertical track with (1) 1/4" - 20 x 9/16" track bolt and (1) 1/4" - 20 flange hex nut. Repeat for other side.

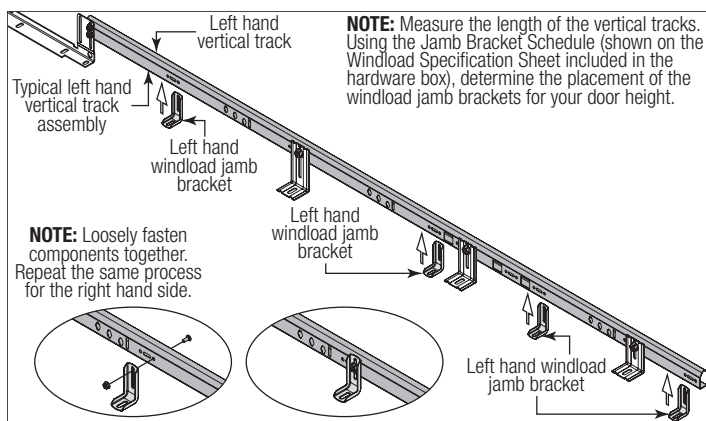

## 4 Attaching Bottom Corner Brackets

**NOTE:** Refer to door section identification, located in the pre-installation section of this manual or refer to Breakdown Of Parts.

**NOTE:** Cable drum assemblies are marked right and left hand.

Uncoil the counterbalance lift cables from the cable drum assemblies.

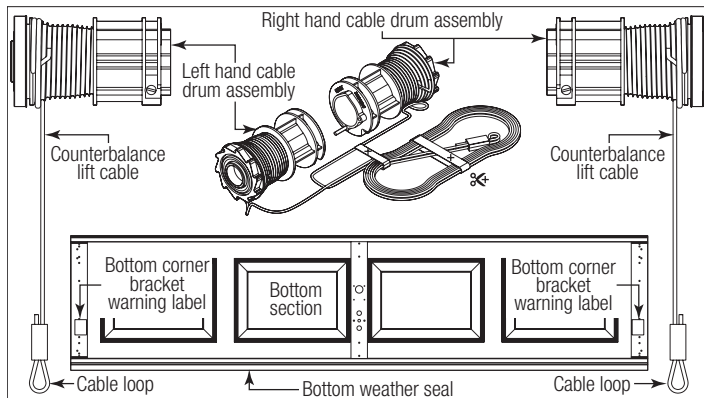

### WARNING

**ENSURE TIGHT FIT OF CABLE LOOP OVER MILFORD PIN TO PREVENT COUNTERBALANCE LIFT CABLE FROM COMING OFF THE PIN, WHICH COULD ALLOW THE DOOR TO FALL AND RESULT IN SEVERE OR FATAL INJURY.**

**NOTE:** Refer to the Windload Specification Sheet to determine if your bottom section requires a strut to be installed over the bottom corner brackets.

**TO ATTACH BOTTOM CORNER BRACKETS:** Starting on the left hand side, the left hand cable loop of the counterbalance lift cable onto milford pin. Position the left hand bottom corner bracket to the left corner of the bottom section, making sure it is seated against the edges of the end stile. Repeat for other side. If applicable, position the strut over the bottom corner brackets and center the strut side to side on the bottom section. Secure the strut (if applicable) and the bottom corner brackets into the endstile using (3) 1/4" - 14 x 7/8" RED HEAD self drilling screws. Finish securing the strut to the bottom section using (2) 1/4" - 14 x 7/8" self drilling screws at each center stile(s) location.

**IMPORTANT:** THE 1/4" - 14 X 7/8" RED HEAD SELF DRILLING SCREWS MUST BE INSTALLED THROUGH THE HOLES OF THE BOTTOM CORNER BRACKETS, AS SHOWN.

**NOTE:** Refer to the Windload Specification Sheet to determine if your bottom section requires extension brackets.

If your door doesn't require extension brackets to be installed, insert a short stem track roller with a roller spacer into each of the bottom corner brackets.

**TO ATTACH EXTENSION BRACKETS:** Position the extension bracket flush against the end stile and slide it underneath the strut. Next, align the extension bracket with the bottom corner bracket by inserting a long shaft roller with a roller spacer through the bottom corner bracket and extension bracket hinge tubes. Attach the extension bracket to the endstile using (3) 1/4" - 14 x 7/8" self drilling screw. Repeat the same process for other side.

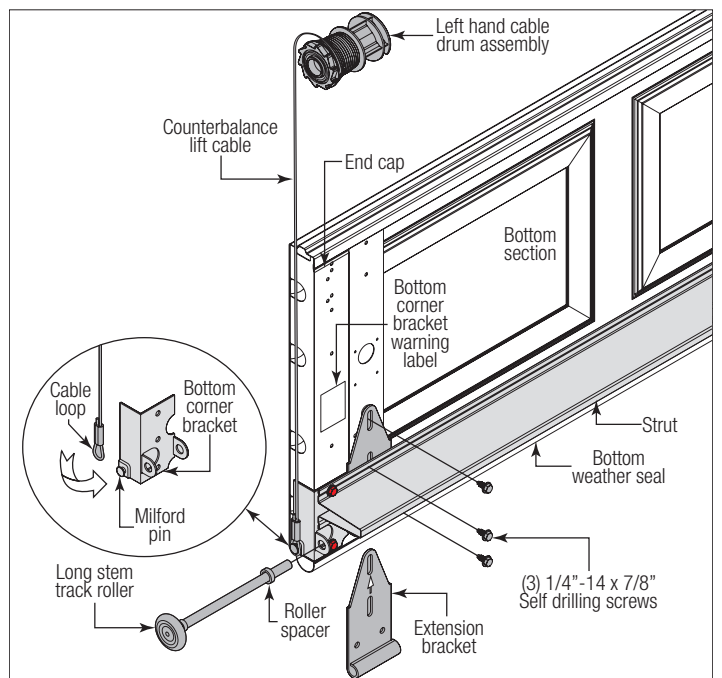
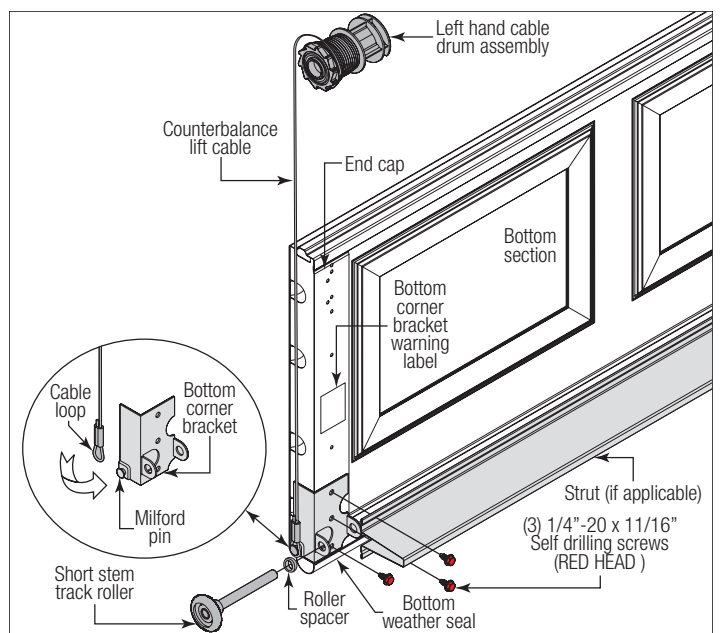

**NOTE:** Verify bottom weather seal is aligned with bottom section. If there is more than 1/2" excess weather seal on either side, trim weather seal even with bottom section.

## 5 Attaching Graduated Hinges

**NOTE:** Refer to door section identification, located in the pre-installation section of this manual.

**NOTE:** The graduated hinges can be identified by the number stamped on the lower hinge leaf.

**NOTE:** Refer to the Windload Specification Sheet to determine the appropriate location for your Wide and or Narrow hinges required for your sections.

**NOTE:** The #1 graduated end hinges serves as end hinges on the bottom section. The #1 graduated end hinges also serves as center hinges on all sections, except for the top section.

**NOTE:** The #2 graduated end hinges serves as end hinges on the Lock section.

**NOTE:** The #3 graduated end hinges serves as end hinges on the Intermediate I section.

**NOTE:** The #4 graduated end hinges serves as end hinges on the Intermediate II section.

Locate the bottom section, using #1 graduated end hinges for the end stiles and depending on the width of your door, enough #1 center hinge(s) for each of the center stile(s). At the top of the bottom section, position the graduated end hinge(s) onto the end stile of the bottom section, so that the lower (#) hinge leaf is over the pre-punched holes in the end stiles and the pre-punched holes of the center stile(s). Secure each graduated end hinge and each center hinge to the bottom section using (2) 1/4" - 14 x 5/8" self tapping screws.

**NOTE:** Refer to the Windload Specification Sheet to determine if two more graduated end hinges are required to be installed next to the previously installed graduated end hinges, as shown.

At the top of the bottom section, position the graduated end hinge onto the inner end stile of the bottom section, so that the lower (#) hinge leaf is over the pre-punched holes in the end stile. Secure each graduated end hinge to the bottom section using (2) 1/4" - 14 x 5/8" self tapping screws.

**NOTE:** Refer to the Windload Specification Sheet to determine if additional 1/4" - 14 x 7/8" self drilling screws are required to be installed into the graduated end hinges, as shown.

**FOR SINGLE GRADUATED END HINGES:** Insert a short stem track roller into the hinge tube of the graduated end hinge on each side.

**FOR DOUBLE GRADUATED END HINGES:** Insert a long stem track roller into the hinge tubes of the graduated end hinges on each side.

**IMPORTANT:** WHEN PLACING TRACK ROLLERS INTO THE #2 GRADUATED END HINGES AND HIGHER, THE TRACK ROLLER GOES INTO HINGE TUBE FURTHEST AWAY FROM SECTION.

**IMPORTANT:** ONCE THE 1/4" - 14 x 5/8" SELF TAPPING SCREWS ARE SNUG AGAINST THE LOWER HINGE LEAF, TIGHTEN AN ADDITIONAL 1/4 TO 1/2 TURN TO RECEIVE MAXIMUM DESIGN HOLDING POWER.

Repeat the same graduated end and center hinge attachment process using the appropriate graduated end hinges for all remaining sections except the top section.

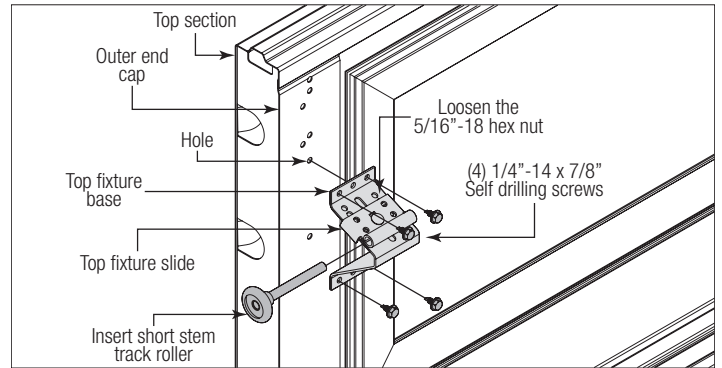
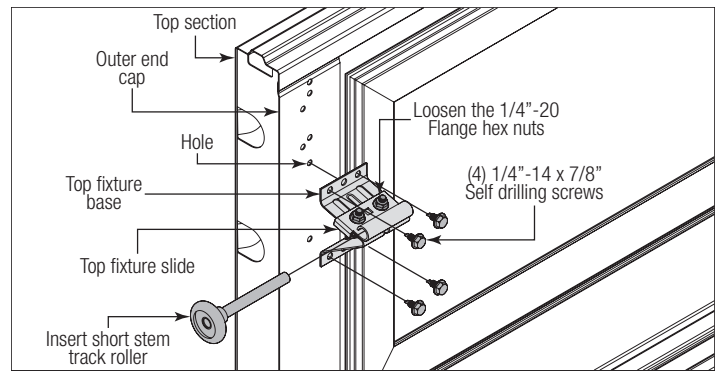
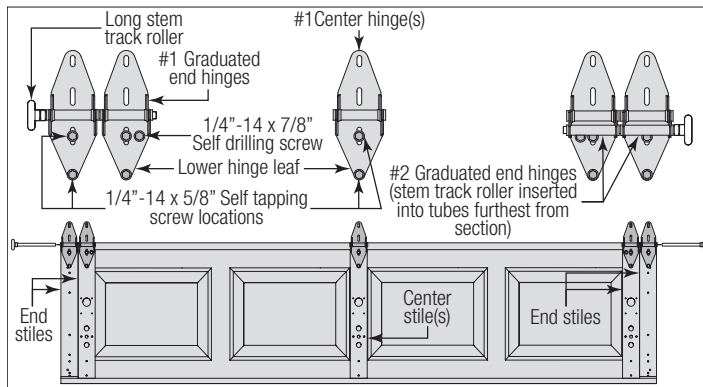
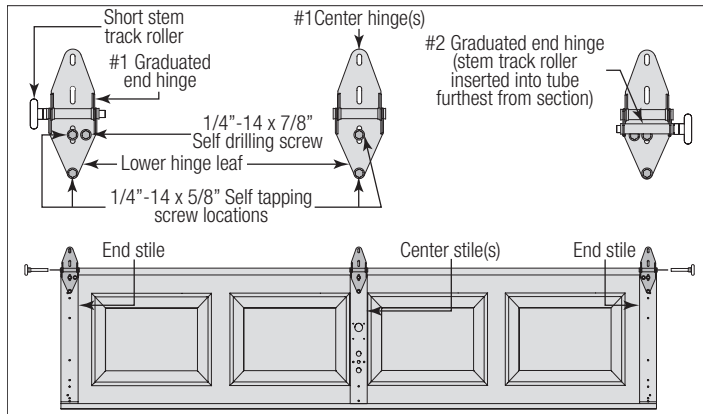

**IF YOUR DOOR CAME WITH FOUR TOP FIXTURES:** Loosen the hex nut on the top fixture assembly. Position the top fixture assembly flush against the inner end stile and centered on the end stile. Insert a long stem track roller through both top fixture slides of the top fixture assemblies, ensuring they are leveled and aligned with each other. Secure top fixture assembly to the end stile using (4) 1/4" - 14 x 7/8" self drilling screws, one in each corner of the top fixture base.

**NOTE:** The top fixture slide will be tightened and adjusted later, in step, Adjusting Top Fixture.

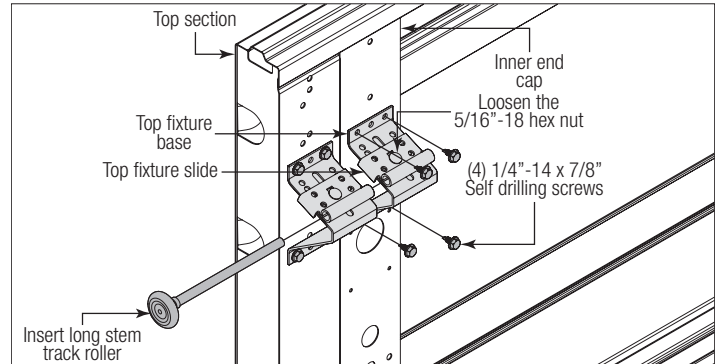

## 6 Attaching Top Fixtures To Top Section

**NOTE:** If your door came with two top fixtures, then one top fixture and a short stem track roller are required for each side.

**NOTE:** If your door came with four top fixtures, then two top fixtures and a long stem track roller are required for each side.

Starting on the left hand side, align the upper-center hole of top fixture base with the hole in the outer end stile of the top section, as shown. Ensure the top fixture base is level and aligned with edge of the top section. Secure with (4) 1/4" - 14 x 7/8" self drilling screws, one in each corner of the top fixture base. Repeat the same process for the right hand side.

**NOTE:** Ensure the top fixture slide is able to slide along the top fixture base. If needed, loosen the 1/4" - 20 flange hex nuts / 5/16" - 18 nuts.

**IF YOUR DOOR CAME WITH TWO TOP FIXTURES:** Insert short stem track roller into top fixture slide. Repeat the same process for the right hand side.

## 7 Attaching Strut(s) To Section

**NOTE:** Refer to door section identification, located in the pre-installation section of this manual or refer to Breakdown Of Parts.

**NOTE:** Refer to the Windload Specification Sheet to determine how many struts your door needs and on what sections they are needed to be installed.

**INSTALLATION FOR THE BOTTOM SECTION:** All struts are placed either up against the bottom of the graduated hinges and or up against the top portion of the bottom corner brackets.

**INSTALLATION FOR THE LOCK AND INTERMEDIATE SECTIONS:** All struts are placed either up against the bottom of the graduated hinges up against the top portion of the graduated hinges.

**INSTALLATION FOR THE TOP SECTION:** All struts are placed either at the top of the section and or up against the top portion of the graduated hinges.

Locate the section and center the strut appropriately onto the section surface. Center the strut side to side. Secure strut to the section using (2) 1/4" - 14 x 7/8" self drilling screws at each end and center stile locations.



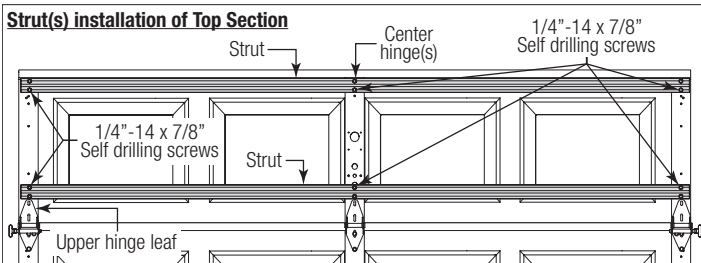
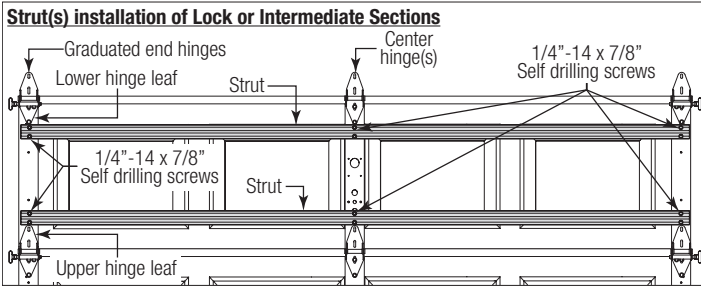
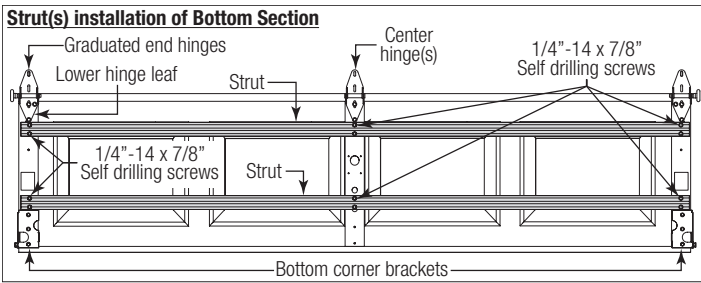

**FOR DOUBLE GRADUATED END HINGES (REFER TO THE WINDLOAD SPECIFICATION SHEET):** Secure (2) 1/4" - 14 x 7/8" self drilling screws more at the inner end stiles of the section.

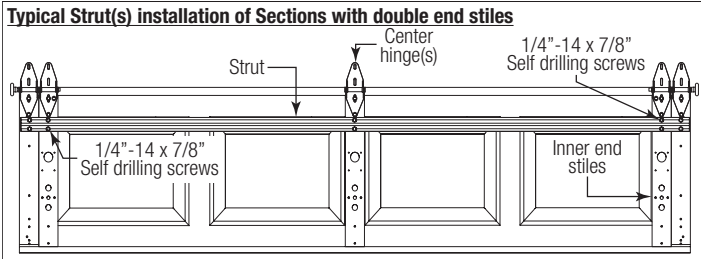

## 8 Step Plate

**NOTE:** Depending on your door, you may have two different kinds of Step Plates or two of the same kind of Step Plates. Refer to Package Contents, to determine which Step Plates you have.

**IF YOU HAVE TWO OF THE SAME KINDS OF STEP PLATES:** Locate the center most center stile of the bottom section of the door. On the inside of the door, center the step plate on the center most stile no higher than 6" from the bottom of the door. Using the step plate holes as a template, drill a 5/16" dia. hole along each side of the center stile, through the face of the door. Drill through insulation and door's face on an insulated door.

**IMPORTANT:** BE EXTREMELY CAREFUL TO KEEP DRILL STRAIGHT.

Mount the inside step plate and the outside step plate back to back, straddling the center stile. Secure with (2) 1/4" - 20 x 2-3/4" carriage bolts and 1/4" - 20 hex nuts.

**IMPORTANT:** DO NOT MOUNT THE STEP PLATE HIGHER THAN 6" FROM THE BOTTOM OF THE SECTION.

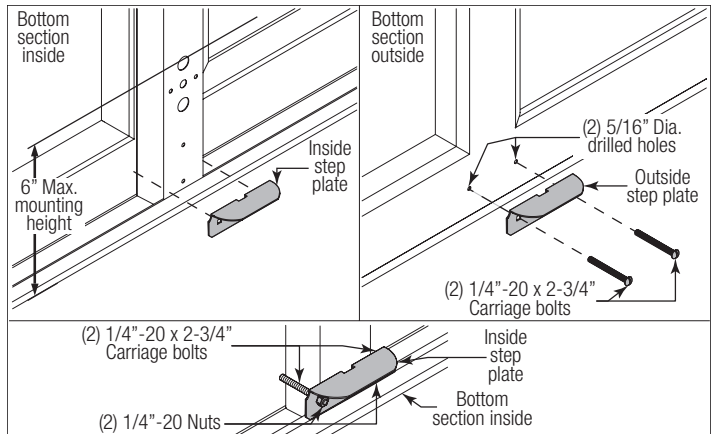

**IF YOU HAVE TWO DIFFERENT KINDS OF STEP PLATES:** Locate the center most center stile on the bottom section of the door. On the inside of the door and using the pre-punched holes at the bottom of the center stile as a template, drill (2) 7/32" dia. holes through the section. Using the previously drilled holes as a guide, enlarge the holes from outside the door to 7/16" dia. and assemble the outside and inside step plates to the section using (2) #8 x 1-5/8" screws.

## CAUTION

DO NOT DRILL THROUGH OR ENLARGE HOLES ON THE INSIDE OF THE DOOR SECTION.

**NOTE:** After completing this step, continue with Step Lift Handles.

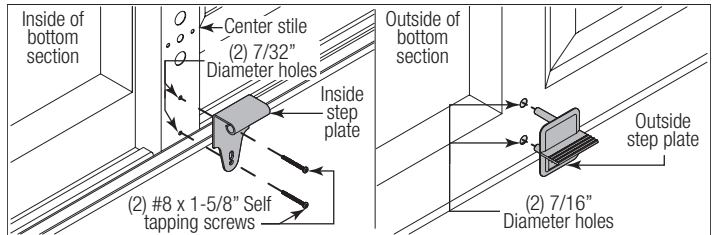

## 9 Lift Handle

**NOTE:** Doors with a Keyed lock do not require this lift handle.

Locate the inside center stile or the desired lift handle location on the lock (2nd) section of the door. Position the lower hole in the lift handle 4" from the bottom of the lock (2nd) section.

**IMPORTANT:** THE DISTANCE BETWEEN THE STEP PLATE AND THE MIDDLE OF THE LIFT HANDLE MUST BE 20" MINIMUM TO 30" MAXIMUM. IF NECESSARY REPOSITION THE UPPER LIFT HANDLE TO STAY WITHIN THE REQUIRED DIMENSION.

Using the lift handle holes as a template, drill (2) 9/32" dia. holes through the lock section. Enlarge the holes from the outside the door to 1/2" dia.

## CAUTION

DO NOT DRILL THROUGH OR ENLARGE HOLES ON THE INSIDE OF THE DOOR SECTION.

Assemble the outside and inside lift handles to the lock section using (2) spacers, (2) 1/4" - 20 x 2-1/2" carriage bolts and (2) 1/4" - 20 hex nuts.

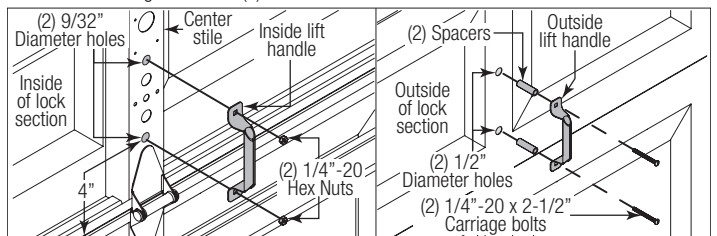

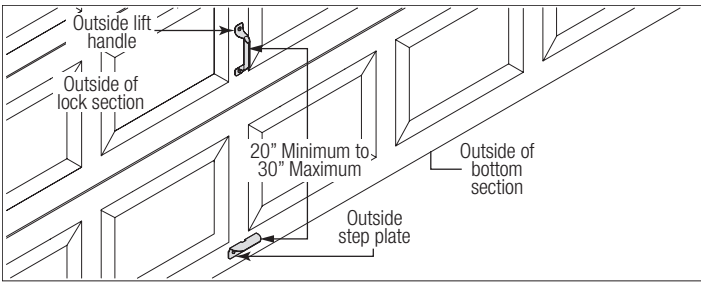

## 10 Positioning Bottom Section

Center the bottom section in the door opening. Level the section using wooden shims (if necessary) under the bottom section. When the bottom section is leveled, temporarily hold it in place by driving a nail into the jamb and bending it over the edge of the bottom section on both sides.

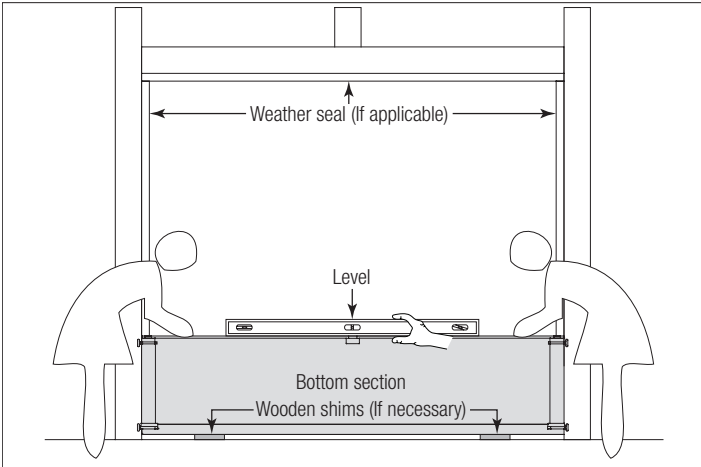

## 11 Attaching Vertical Tracks To Jamb

**IMPORTANT:** IF YOUR DOOR IS TO BE INSTALLED PRIOR TO A FINISHING CONSTRUCTION OF THE BUILDING'S FLOOR, THE VERTICAL TRACKS AND THE DOOR BOTTOM SECTION ASSEMBLY SHOULD BE INSTALLED SUCH THAT WHEN THE FLOOR IS CONSTRUCTED, NO DOOR OR TRACK PARTS ARE TRAPPED IN THE FLOOR CONSTRUCTION.

**IMPORTANT:** THE TOPS OF THE VERTICAL TRACKS MUST BE LEVEL FROM SIDE TO SIDE. IF THE BOTTOM SECTION WAS SHIMMED TO LEVEL IT, THE VERTICAL TRACK ON THE SHIMMED SIDE MUST BE RAISED THE HEIGHT OF THE SHIM.

**NOTE:** Make sure the counterbalance lift cable is located between the track rollers and the door jamb.

Starting on the left hand side of the bottom section, remove the nail. Position the left hand vertical track assembly over the track rollers of the bottom section and install, as shown. Drill 3/16" pilot holes into the door jamb for the lag screws.

Loosely fasten jamb brackets and flag angle to the jamb using 5/16" x 1-5/8" lag screws. Tighten lag screws, securing the bottom jamb bracket to jamb, maintain 3/8" to 5/8" spacing, between the bottom section and vertical track. Hang counterbalance lift cable over flag angle. Repeat same process for other side.

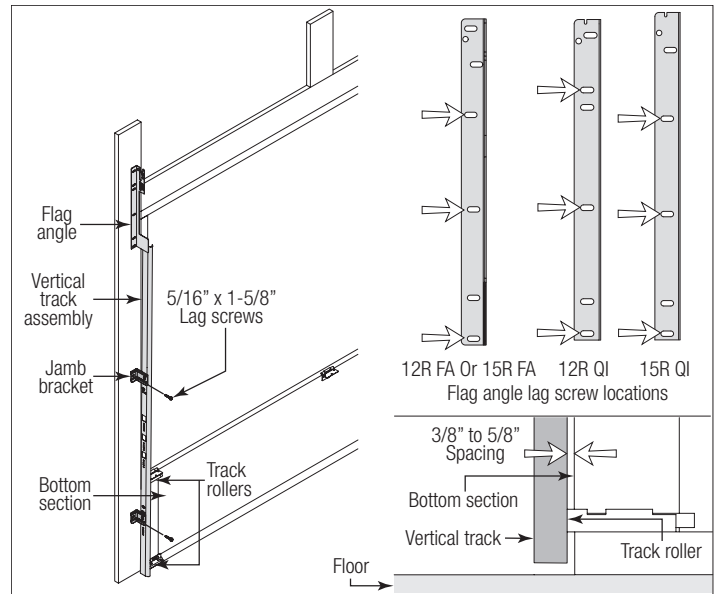

## 12 Stacking Sections

**NOTE:** The sections can be identified by the graduation of the installed graduated end hinges. The smallest graduated end hinge on the section should be stacked on top of the bottom section, with each graduated end hinge increasing as the sections are stacked, see Door Section Identification.

**NOTE:** Make sure graduated end and center hinges are flipped down, when stacking another section on top.

With assistance, lift second section and guide the track rollers into the vertical tracks. Lower section until it is seated against bottom section. Flip hinges up. Fasten center hinge(s) first; then end hinges last using 1/4" - 14 x 5/8" self tapping screws. Repeat same process for other sections, except top section.

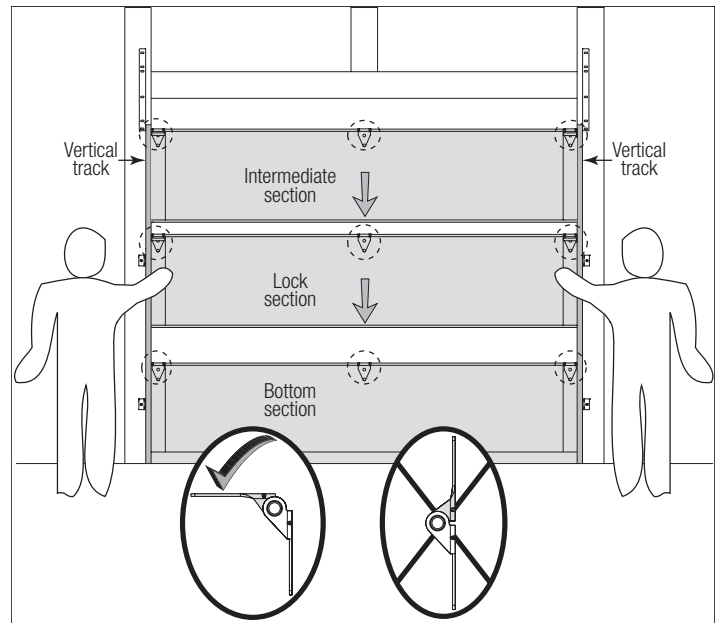

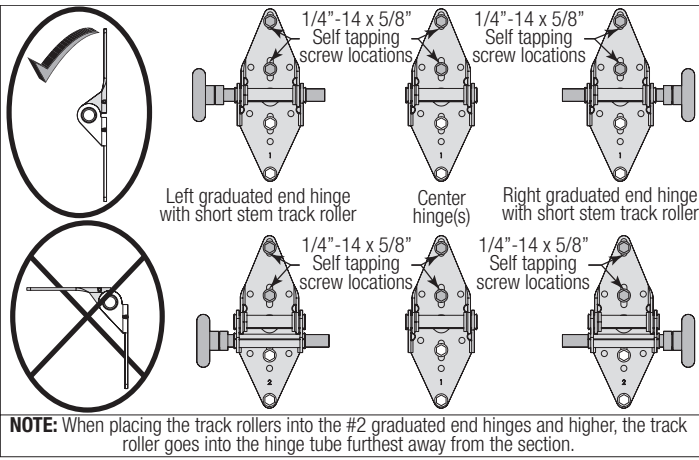

**NOTE:** When placing the track rollers into the #2 graduated end hinges and higher, the track roller goes into the hinge tube furthest away from the section.

**NOTE:** Refer to the Windload Specification Sheet to determine if additional 1/4" - 14 x 7/8" self drilling screws are required to be installed into the graduated end hinges, as shown.

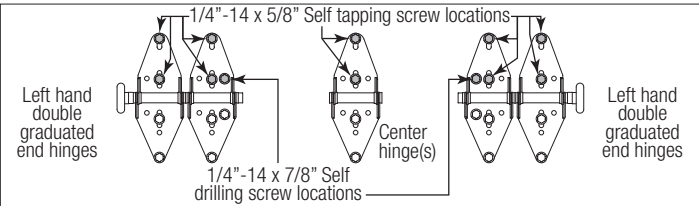
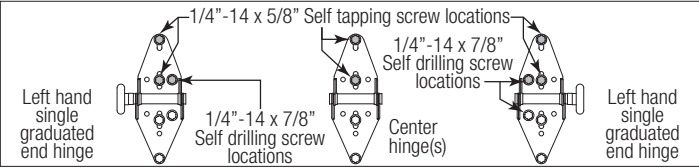

**IMPORTANT:** PUSH & HOLD THE HINGE LEAFS SECURELY AGAINST THE SECTIONS WHILE SECURING WITH THE 1/4" - 14 X 5/8" SELF TAPPING SCREWS AND OR THE 1/4" - 14 X 7/8" SELF DRILLING SCREWS. THERE SHOULD BE NO GAP BETWEEN THE HINGE LEAFS AND THE SECTIONS.

**NOTE:** Install lock at this time (sold separately). See optional installation step, Side Lock.

## 13 Stacking Top Section

Place the top section in the opening. Install a nail to prevent the top section from falling backwards. Now, flip up the hinge leaves, hold tight against section, and fasten center hinges first and end hinges last (refer to step, Stacking Sections). Vertical track alignment is critical. Position flag angle or wall angle between 1-11/16" (43 mm) to 1-3/4" (44 mm) from the edge of the door; tighten the bottom lag screw. Flag angles must be parallel to the door sections. Repeat for other side.

**IMPORTANT:** THE DIMENSION BETWEEN THE FLAG ANGLES OR WALL ANGLES MUST BE DOOR WIDTH PLUS 3-3/8" (86MM) TO 3-1/2" (89 MM) FOR SMOOTH, SAFE DOOR OPERATION.

**FOR QUICK INSTALL TRACK:** Complete the vertical track installation by securing the jamb bracket(s) and tightening the other lag screws. Repeat for other side.

**FOR FULLY ADJUSTABLE TRACK OR RIVETED TRACK:** Complete the vertical track installation by securing the jamb bracket(s) and tightening the other lag screws. Push the vertical track against the track rollers so that the track rollers are touching the deepest part of the curved side of the track; tighten all the track bolts and nuts. Repeat for other side.

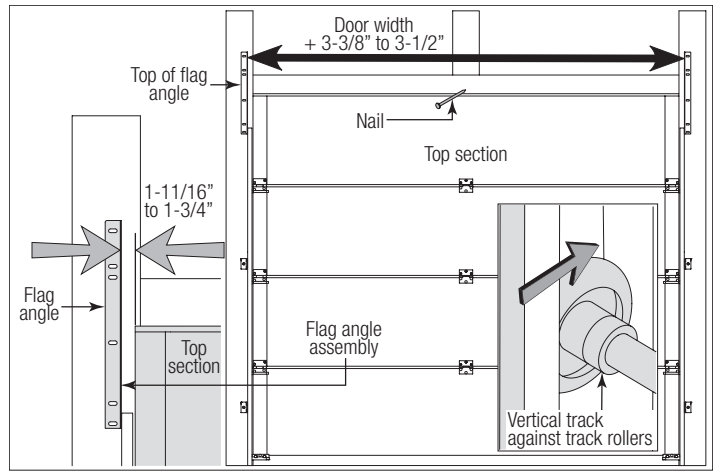

## 14 Attaching Horizontal Tracks

**NOTE:** Depending on your door, you may have Quick Install Flag Angles, Fully Adjustable Flag Angles or you may have Riveted Vertical Track Assemblies. Refer to Package Contents / Breakdown of Parts, to determine which Flag Angles / Vertical Track Assemblies you have.

### WARNING

**DO NOT RAISE DOOR UNTIL HORIZONTAL TRACKS ARE SECURED AT REAR, AS OUTLINED IN STEP, REAR BACK HANGS, OR DOOR COULD FALL FROM OVERHEAD POSITION CAUSING SEVERE OR FATAL INJURY.**

**IF YOU HAVE QUICK INSTALL FLAG ANGLES:** To install horizontal track, place the curved end over the top track roller of the top section. Align key slot of the horizontal track with the Quick Install tab of the flag angle. Push curved portion of horizontal track down to lock in place.

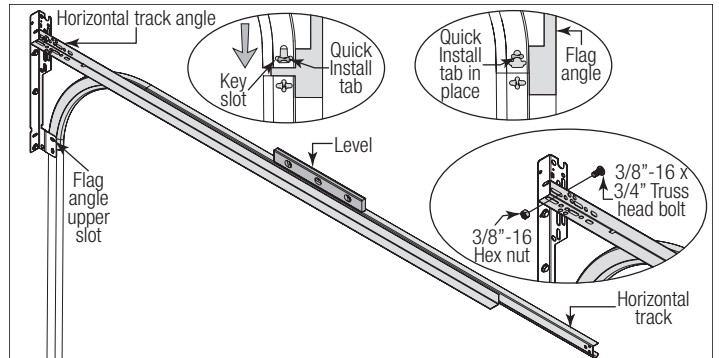

**FOR OTHER FLAG ANGLES:** To install horizontal track, place the curved end over the top track roller of the top section. Align the bottom of the horizontal track with the top of the vertical track. Tighten the horizontal track to the flag angle with (2) 1/4" - 20 x 9/16" track bolts and (2) 1/4" - 20 flange hex nuts.

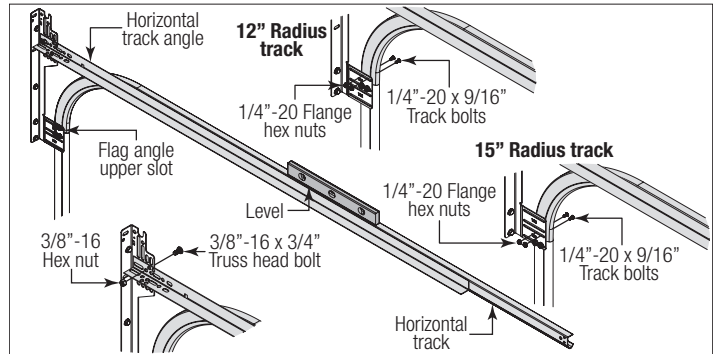

Next level the horizontal track assembly and bolt the horizontal track angle to the first encountered slot in the flag angle / angle mount using (1) 3/8" - 16 x 3/4" truss head bolt and (1) 3/8" - 16 hex nut. Repeat for other side. Remove nail that was temporarily holding the top section in position.

**IMPORTANT:** FAILURE TO REMOVE NAIL BEFORE ATTEMPTING TO RAISE DOOR COULD CAUSE PERMANENT DAMAGE TO TOP SECTION.

# COUNTERBALANCE INSTALLATION INSTRUCTIONS

## 16

### Preparing The TorqueMaster® Spring Tube Assembly

**NOTE:** TorqueMaster® springs come lubricated and pre-assembled inside the TorqueMaster® spring tube.

To prepare for install, lay the spring tube assembly on the floor, inside garage, in front of the door, and with the labeled end to the left. Next, remove the shipping boots from the ends of the TorqueMaster® spring tube.

Being cam shaped, the center bushing only fits one way. Slide the center bracket bushing assembly towards the center of the TorqueMaster® spring tube, from the right side, as shown.

**NOTE:** Refer to Package Contents / Breakdown of Parts, to determine if you have drum wraps (optional).

Drum wraps (optional) are marked right and left hand. Beginning with the left hand side, slide the left hand drum wrap onto the TorqueMaster® spring tube. Repeat for the right hand side. The drum wrap will be secured later, in Step, Securing Drum Wraps.

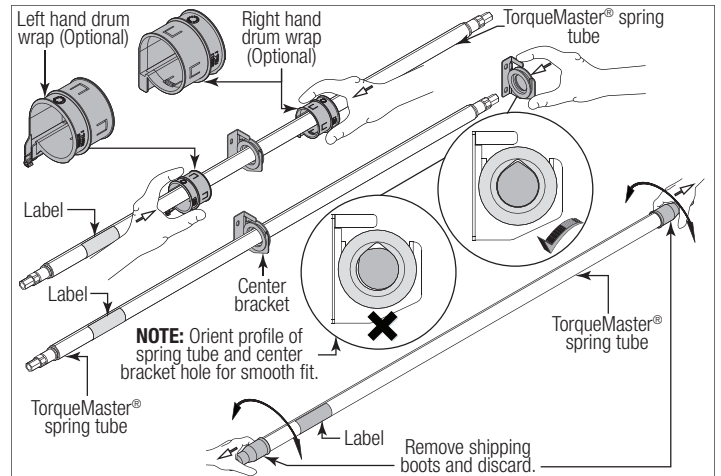

## 17

### Installing Cable Drum Assemblies

**NOTE:** Cable drum assemblies are marked right and left hand. Cable drums and TorqueMaster® spring tube assembly are cam shaped to fit together only one way.

Shake the TorqueMaster® spring tube assembly gently to extend the winding shafts out about 5" on each side. For **single spring applications**, there will be no left hand spring in the TorqueMaster® spring tube assembly. Lift the TorqueMaster® spring tube assembly and rest it on top of the flag angles.

**NOTE:** Temporarily support the center of the TorqueMaster® spring tube assembly until the center bracket is installed in Step Attaching Center Bracket to Wall.

**NOTE:** For single spring applications, there will be no left hand spring in the TorqueMaster® spring tube assembly.

**NOTE:** If winding shaft is not visible out of the right hand side, gently shake the TorqueMaster® spring tube until winding shaft sticks out 5".

**NOTE:** If both winding shafts are not visible, gently shake the TorqueMaster® spring tube until both winding shaft sticks out 5".

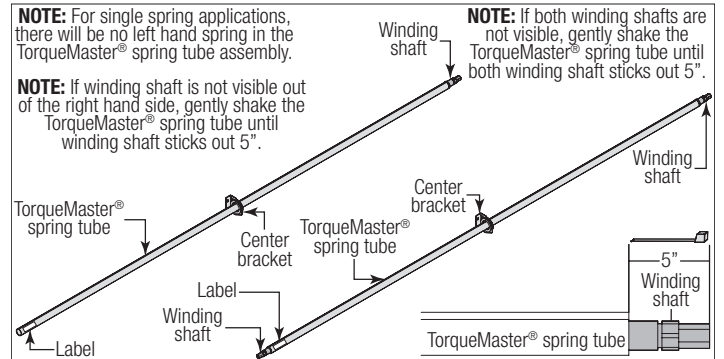

## 15

### Adjusting Top Fixtures

With horizontal tracks installed, you can now adjust the top fixtures. Vertically align the top section of the door with the lower sections. Once aligned, position the top fixture slide(s), out against the horizontal track. Maintaining the slide(s) position either tighten the (2) 1/4" - 20 flange hex nuts / 5/16" - 18 hex nut to secure the top fixture slide(s) to the top fixture base(s). Repeat for other side.

**NOTE:** Refer to the Windload Specification Sheet to determine if additional 1/4" - 20 x 9/16" track bolt and (1) 1/4" - 20 flange hex nut is required to be installed into the top fixture slide.

Lock each of the top fixture slide in position using (1) 1/4" - 20 x 9/16" track bolt and (1) 1/4" - 20 flange hex nut through any aligning hole. Repeat for other side.

**NOTE:** Refer to the Windload Specification Sheet to determine if pushnuts are required to be installed onto the shaft of track roller stems.

**IMPORTANT:** ACCURATELY POSITIONING THE PUSHNUT ONTO THE ROLLER STEM IS CRITICAL. ONCE THE PUSHNUT IS PUSHED ONTO THE ROLLER STEM, THE TABS MAKING CONTACT WITH THE STEEL SURFACE WILL MAKE IT DIFFICULT TO REPOSITION THE PUSHNUT.

**NOTE:** When positioning the pushnut onto roller stem, ensure the tabs on the pushnut are pointing away from roller stem.

Starting with the top fixture assembly, slide (1) pushnut over the roller stem and push the pushnut towards the outside edge of the top fixture assembly leaving 1/4" spacing between the outside edge of top fixture assembly and the pushnut. Repeat same process for the graduate end hinges and the bottom corner brackets on the left hand side of door, then repeat same process for the right hand side of door.

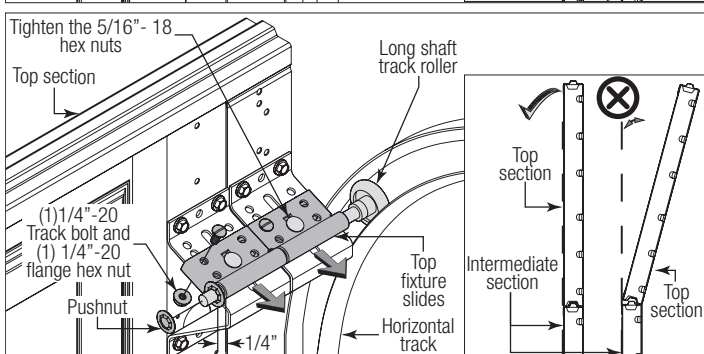
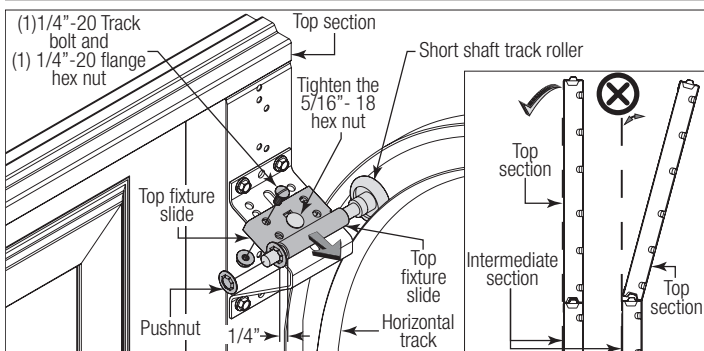
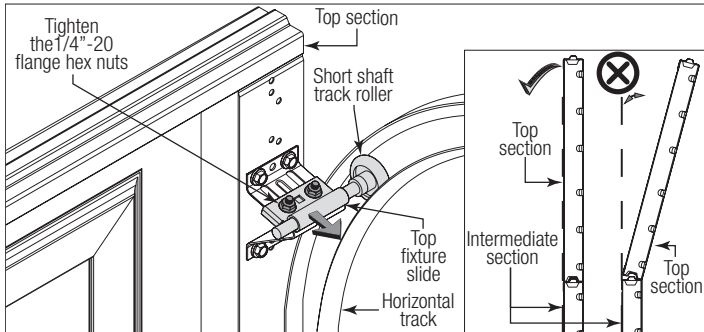

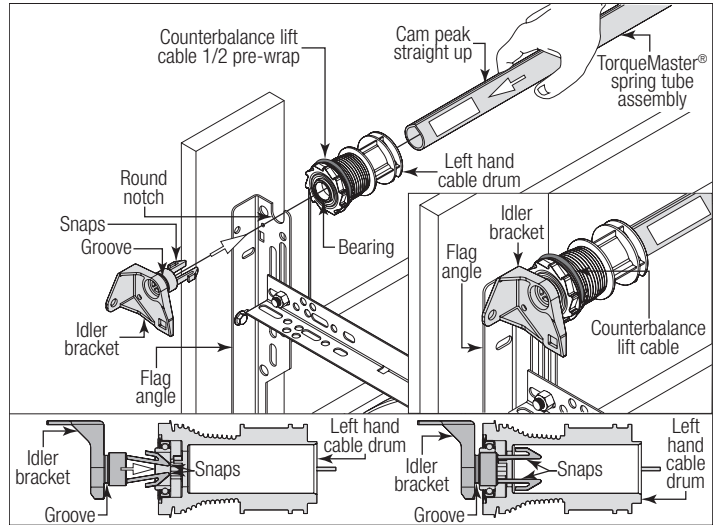
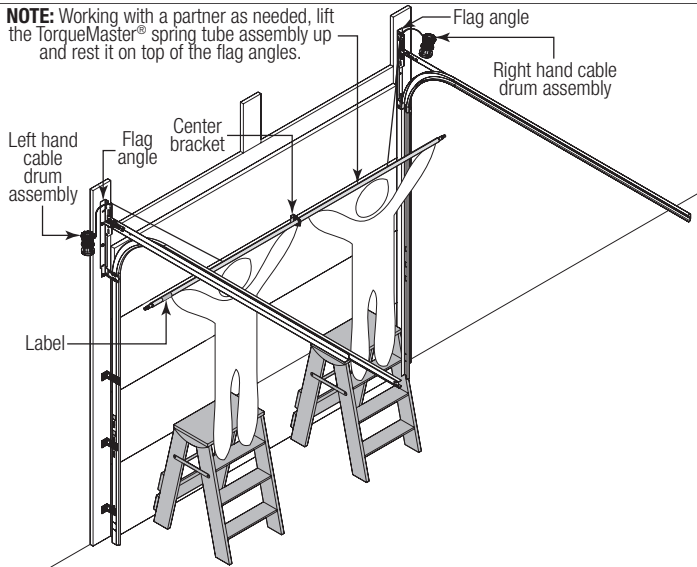

## 18 Attaching End Brackets To Flag Angles

**IMPORTANT:** WARNING TAGS MUST BE SECURELY ATTACHED TO END BRACKET(S).  
**IMPORTANT:** FOR SINGLE SPRING DOORS, ENSURE THE LEFT HAND CABLE DRUM BEARING IS ALL THE WAY TO THE LEFT AND UP AGAINST THE FLAG ANGLE. IF THE CABLE DRUM IS PULLED AWAY FROM THE FLAG ANGLE, THEN THE IDLER BRACKET CAN RUB AGAINST THE CABLE DRUM CAUSING NOISE.

**NOTE:** Drill 3/16" pilot holes into header for the lag screws.  
 Beginning with the right hand side, slide the end bracket onto the winding shaft so that the splines in the ratchet wheel fit onto the winding shaft grooves. Attach the end bracket to the flag angle using (1) 5/16" - 18 x 3/4" carriage bolt, (1) 5/16" washer and (1) 5/16" - 18 hex nut. Then secure the end bracket to the jamb using (1) 5/16" x 1-5/8" lag screw.

**NOTE:** If ratchet wheel falls out of end bracket, refer to illustration for proper insertion orientation.

**FOR DOUBLE SPRING APPLICATIONS:** Repeat same process for left hand end bracket.

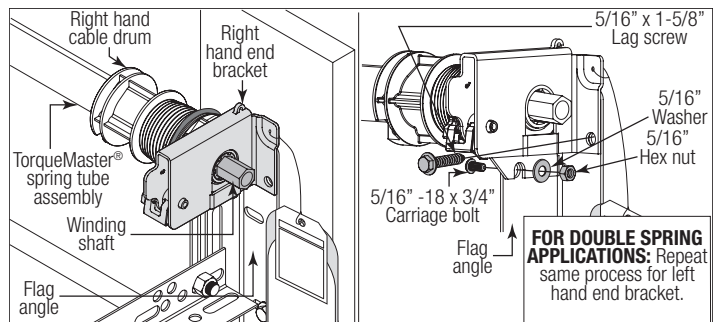
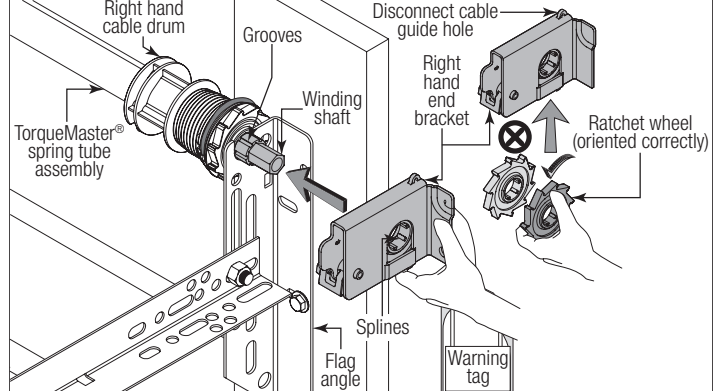

**FOR SINGLE SPRING APPLICATIONS:** Secure the idler bracket to the flag angle using (1) 5/16" - 18 x 3/4" carriage bolt, (1) 5/16" washer and (1) 5/16" - 18 hex nut. Then secure the idler bracket to the jamb using (1) 5/16" x 1-5/8" lag screw.

**NOTE:** Cable drum assemblies are marked right and left hand. Cable drums and TorqueMaster® spring tube assembly are cam shaped to fit together only one way.

Starting on the right hand side, pre-wrap the cable drum with the counterbalance lift cable 1/2 wrap, as shown. Position the TorqueMaster® spring tube assembly so the cam peak is pointing straight up. Slide the cable drum over the winding shaft until the cable drum seats against the TorqueMaster® spring tube assembly. The winding shaft must extend past the cable drum far enough to expose the splines and the grooves. Align the winding shaft grooves with the round notch in the flag angle.

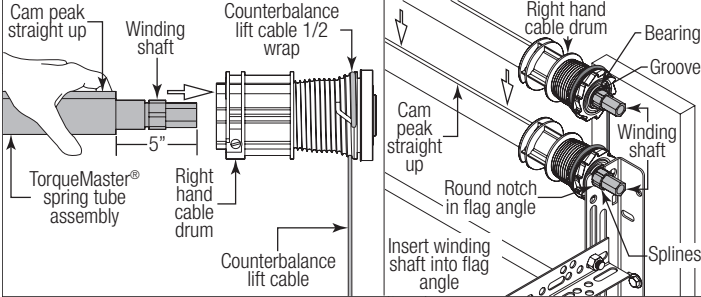

**FOR DOUBLE SPRING APPLICATIONS:** Repeat for left hand side.

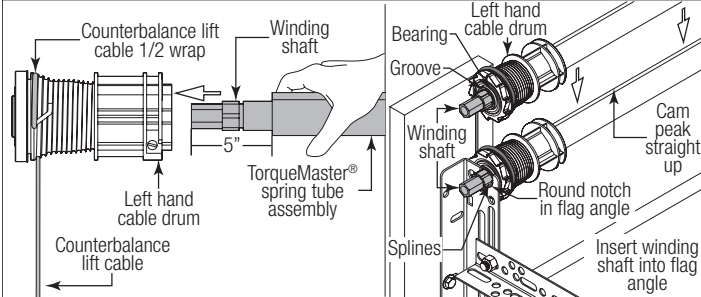

**FOR SINGLE SPRING APPLICATIONS:** Insert the idler bracket into the left hand cable drum. Lightly press the idler bracket into the cable drum until two distinct clicks are heard, or the bracket is inserted all the way.

**IMPORTANT:** ENSURE THE SNAPS ON THE IDLER BRACKET (LEFT HAND SIDE) ARE ENGAGED INTO THE LEFT HAND CABLE DRUM, SO THAT IT DOES NOT COME BACK OUT.

**NOTE:** The idler bracket is designed for permanent assembly. Do not attempt to remove idler bracket once inserted into the cable drum.

**NOTE:** The idler bracket must extend past the cable drum far enough to expose the groove. Align the idler bracket groove with the round notch in the flag angle.

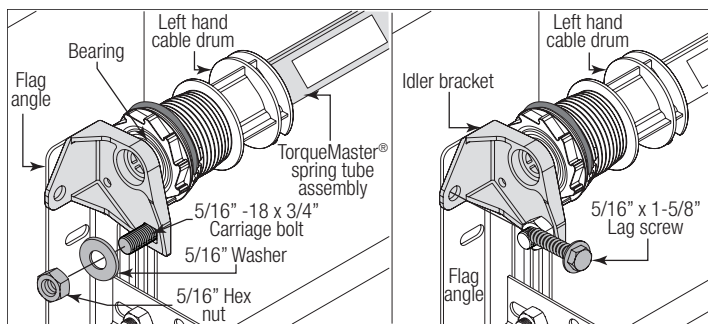

## 19 Attaching Center Bracket to Wall

**IMPORTANT:** TORQUEMASTER® SPRING TUBE MUST BE LEVEL BEFORE SECURING CENTER BRACKET BUSHING ASSEMBLY TO HEADER.

**NOTE:** Drill 3/16" pilot holes into header for the lag screws.

To locate the center bracket bushing assembly, mark the header halfway between the flag angles and level the TorqueMaster® spring tube. Fasten the center bracket bushing assembly to the header using (2) 5/16" x 1-5/8" lag screws.

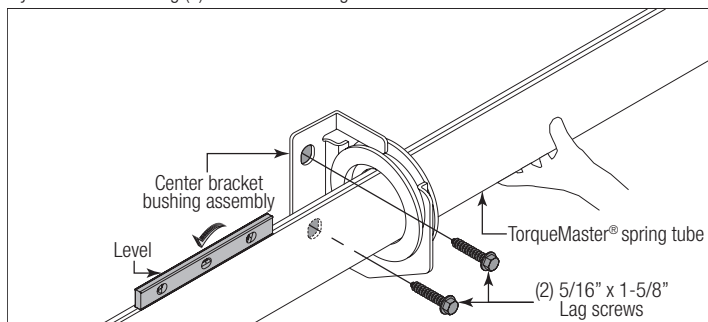

## 20 Securing Door For Winding Spring(s)

With the door in the fully closed position, place locking pliers onto both vertical tracks just above the third track roller. This is to prevent the garage door from rising while winding spring(s).

**NOTE:** Check the following before attempting to wind spring(s):

- Counterbalance lift cables are secured at bottom corner brackets.
- Counterbalance lift cables are routed unobstructed to cable drums.
- Counterbalance lift cables are correctly installed and wound onto cable lift drums.
- TorqueMaster® spring tube is installed correctly.
- Review the label attached to the spring warning tag, to determine number of spring turns required.

**NOTE:** Door MUST be closed and locked when winding or making any adjustments to the spring(s).

### ⚠ WARNING

**FAILURE TO PLACE LOCKING PLIERS ONTO VERTICAL TRACK CAN ALLOW DOOR TO RAISE AND CAUSE SEVERE OR FATAL INJURY.**

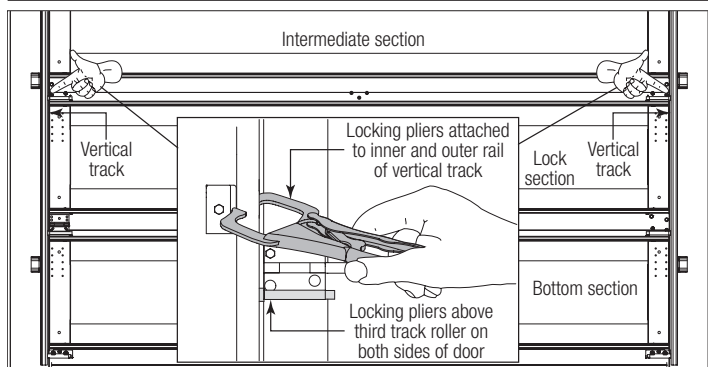

## 21

## Adjusting Counterbalance Lift Cable

Starting on the right side, adjust the cable drum assembly by rotating the drum until the set screw faces directly away from the header. The position of the cam peak on the TorqueMaster® spring tube should be pointing straight up.

Loosen the set screw no more than 1/2 turn. Ensure counterbalance lift cable is aligned and seated in the first and second grooves of the cable drum. Pull on the end of the cable to remove all cable slack.

Snug the set screw and then tighten an additional 1-1/2 turns. Measure approximately 6" of cable and cut off excess cable. Insert end of the cable into the hole of cable drum. Repeat for left hand cable drum assembly.

**IMPORTANT:** ENSURE THE COUNTERBALANCE LIFT CABLE IS SEATED IN THE FIRST GROOVE OF THE CABLE DRUM PRIOR TO WINDING SPRINGS.

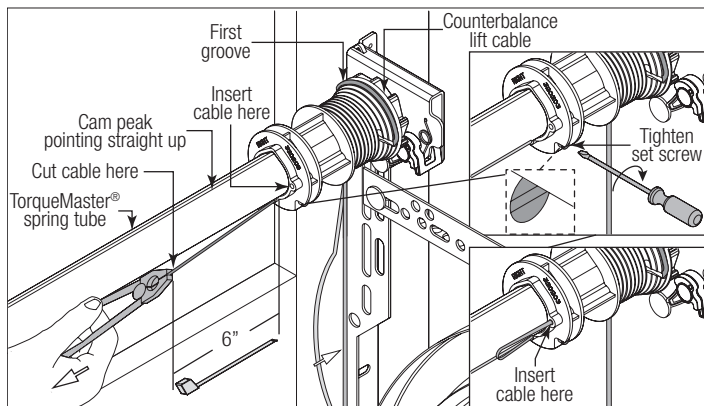

**NOTE:** Illustration shows the right hand cable drum assembly. Repeat the same process for the left hand side.

## 22

## Winding Spring(s)

**IMPORTANT:** VERIFY THAT THERE ARE NO OBSTRUCTIONS IN THE TRAVEL PATH OF THE DOOR SECTIONS OR COUNTERBALANCE LIFT CABLES.

**IMPORTANT:** INSPECT EACH COUNTERBALANCE LIFT CABLE MAKING SURE IT IS SEATED PROPERLY ONTO THE CABLE DRUM AND THAT BOTH COUNTERBALANCE LIFT CABLES HAVE EQUAL TENSION.

**PRIOR TO WINDING SPRING(S), CHECK COUNTERBALANCE LIFT CABLES FOR EQUAL TENSION:**

- Attach locking pliers to track above top roller.
- Grasp cable at approximate mid-door height location.
- Draw cable toward you about 1/2" to 1" and release, noting the response of the cable.
- Repeat above steps for other cable.
- Adjust cable tension as needed until right and left cables both respond the same.

### ⚠ WARNING

**WINDING SPRING IS AN EXTREMELY DANGEROUS PROCEDURE AND SHOULD BE PERFORMED ONLY BY A TRAINED DOOR SYSTEM TECHNICIAN USING PROPER TOOLS AND INSTRUCTIONS.**

### ⚠ WARNING

**IT IS RECOMMENDED THAT LEATHER GLOVES BE WORN WHILE WINDING SPRINGS. FAILURE TO WEAR GLOVES MAY CAUSE INJURY TO HANDS.**

**NOTE:** A 3" ratchet extension is recommended for added clearance from the horizontal track angle.

**IMPORTANT:** PAWL KNOB MUST BE IN UPPER POSITION TO ADD / REMOVE REQUIRED NUMBER OF SPRING TURNS.

There are two methods for counting the spring turns as you wind. One method is to identify the black tooth on the ratchet wheel inside of the end bracket. When the wheel makes one revolution and the tooth returns to its starting point, one turn has been made. The other method is to make a mark on the winding shaft (or socket) and end bracket, and count your turns in this manner.

Check the label attached to the spring warning tag or the Winding Spring Turn Chart (below) for the required number of complete turns to balance your door.

Starting on the right hand side, turn the pawl knob on the end bracket to the upper position. Using a ratchet wrench with a 5/8" socket and a 3" ratchet extension, wind the spring by rotating the winding shaft counter clockwise, while watching either the black tooth on the

ratchet wheel or the mark on the winding shaft. After 2 to 3 turns, remove the ratchet wrench and adjust the counterbalance lift cable on the left side. Ensure counterbalance lift cables are in the first groove of the cable drums, as shown in Step Adjusting Counterbalance Lift Cable.

**NOTE:** Single spring applications require no spring winding on the left hand side, but lift cable tension needs to be adjusted.

**FOR SINGLE SPRING APPLICATIONS:** Return to the right hand end bracket and continue winding the spring to the required number of turns for your door following the double spring instructions below. Place pawl knob in lower position.

**FOR DOUBLE SPRING APPLICATIONS:** Either use the black tooth on the ratchet wheel for winding reference or place a mark on the winding shaft and end bracket. Place the ratchet wrench with 5/8" socket and a 3" ratchet extension onto the left hand winding shaft end. To wind the spring, rotate the winding shaft clockwise, while watching the black tooth on the ratchet wheel or the mark on the winding shaft. Rotate the winding shaft to the required number of winding turns for your door. Then return to the right hand side and wind the right hand spring to the required number of turns. Place pawl knob in lower position on both sides.

**IMPORTANT:** MARK THE NUMBER OF SPRING TURNS ONTO THE END BRACKET WARNING TAG.

**WINDING SPRING TURN CHART**

DOOR HEIGHT	SPRING TURNS
6'-0"	14
6'-3"	14-1/2
6'-5" - 6'-6"	15
6'-8" - 6'-9"	15-1/2
7'-0"	16
7'-3"	16-1/2
7'-6"	17
7'-9"	17-1/2
8'-0"	18

**NOTE:** Since total turns to balance door can deviate from winding spring turn chart values by ± 1 turn, adjustments to the recommended number of turns may be required after rear back hangs are installed.

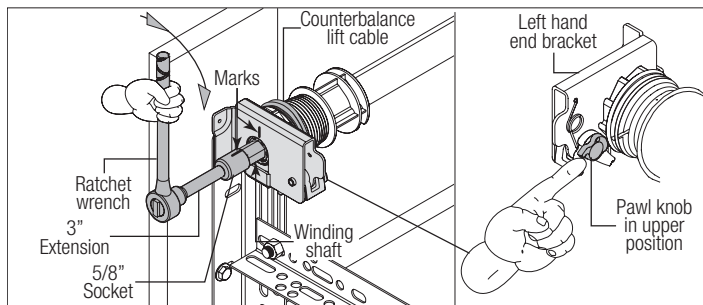
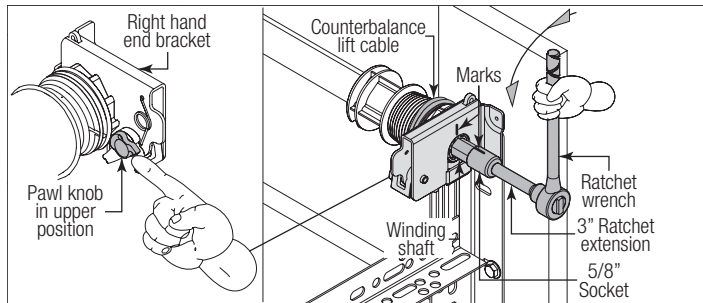

## 23 Securing Drum Wraps (Optional)

**NOTE:** If you don't have drum wraps, then skip this step. Refer to Package Contents / Parts Breakdown, to determine if you have drum wraps.

Starting on the left hand side, position the left hand drum wrap, as shown. Slide the left hand drum wrap over the cable drum assembly.

**IMPORTANT:** PULL THE COUNTERBALANCE LIFT CABLE AWAY FROM THE HEADER TO CLEAR THE LATCH, WHILE SIMULTANEOUSLY SLIDING THE DRUM WRAP AGAINST THE LAST RIB UNTIL THE THREE CATCHES ENGAGE THE 3<sup>RD</sup> RIB.

Secure the hinge latch by rotating upward until a distinct snap is felt. Confirm the catch is fully engaged by lightly tugging on it. Repeat the same process for right hand side.

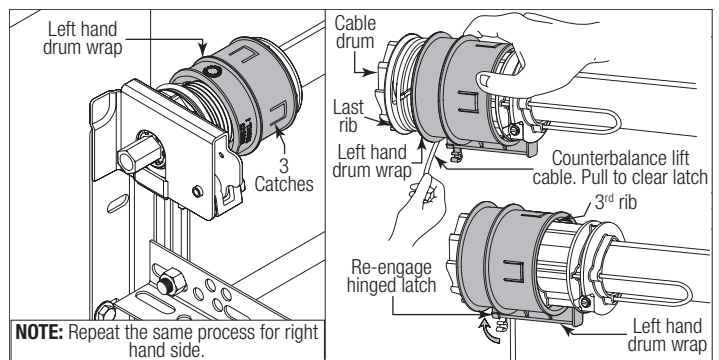

## 24 Attaching Rear Back Hangs

**IMPORTANT:** HOLD THE DOOR DOWN TO PREVENT IT FROM RISING UNEXPECTEDLY IN THE EVENT THE SPRING(S) WERE OVER-WOUND AND CAUTIOUSLY REMOVE LOCKING PLIERS FROM VERTICAL TRACKS.

Raise the door until the top section and half of the next section are in the horizontal track radius. Do not raise door any further since rear of horizontal tracks are not yet supported.

### WARNING

**RAISING DOOR INTO THE LOOSE HORIZONTAL TRACKS CAN RESULT IN DOOR FALLING AND CAUSE SEVERE OR FATAL INJURY.**

Clamp a pair of locking pliers onto the vertical tracks just above the second track roller on one side, and just below the second track roller on the other side. This will prevent the door from raising or lowering while installing the rear back hangs.

Using the chart below, select the appropriate perforated angle (may not be supplied). Fabricate and install rear back hangs, as shown.

**Perforated Angle Gauge Weight Limitations:**

Perforated Angle Gauge	Door Balance Weight
2" x 2" x 12 Gauge	800 lbs. to 1600 lbs.
1-1/4" x 1-1/4" x 13 Gauge	305 lbs. to 610 lbs.
1-1/4" x 1-1/4" x 15 Gauge	220 lbs. to 440 lbs.
1-1/4" x 1-1/4" x 16 Gauge	175 lbs. to 350 lbs.

**NOTE:** If an opener is installed, position horizontal tracks one hole above level when securing them to the rear back hangs.

### WARNING

**KEEP HORIZONTAL TRACKS PARALLEL AND WITHIN 3/4" TO 7/8" MAXIMUM OF DOOR EDGE, OTHERWISE DOOR COULD FALL, RESULTING IN SEVERE OR FATAL INJURY.**

### WARNING

**MAKE SURE BACK HANGS ARE BRACED SUFFICIENTLY TO RESIST ANY MOTION DURING SPRING APPLICATION AND DOOR TRAVEL. IF BACK HANGS PIVOT OR DEFLECT, ADD REINFORCEMENT UNTIL THEY REMAIN FIRM AND STATIONARY. ANY BACK HANG THAT HAS BENT MUST BE REPLACED.**

**IMPORTANT:** DO NOT SUPPORT THE WEIGHT OF THE DOOR ON ANY PART OF THE REAR BACK HANGS THAT CANTILEVERS 4" OR MORE BEYOND A SOUND FRAMING MEMBER.

**NOTE:** If rear back hangs are to be installed over drywall, use (2) 5/16" x 2" hex head lag screws and make sure lag screws engage into solid structural lumber.

### WARNING

**FAILURE TO ASSEMBLE AND ATTACH REAR BACK HANGS PROPERLY ACCORDING TO THE ABOVE INSTRUCTIONS MAY RESULT IN DOOR FALLING WHEN RAISED, CAUSING SEVERE OR FATAL INJURY.**

**NOTE:** Perforated angle must be attached to sound framing members and **nails should not be used.**

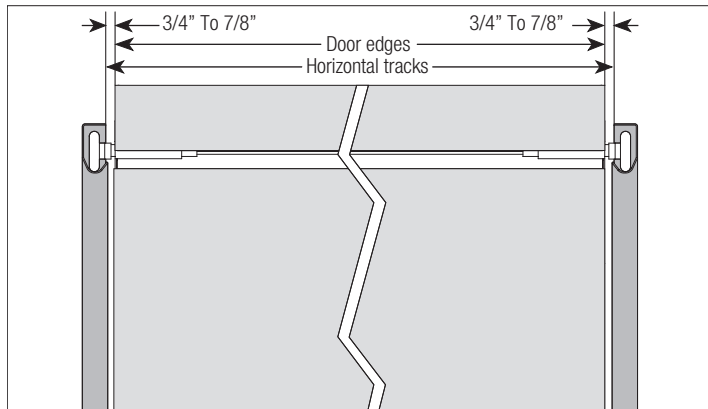
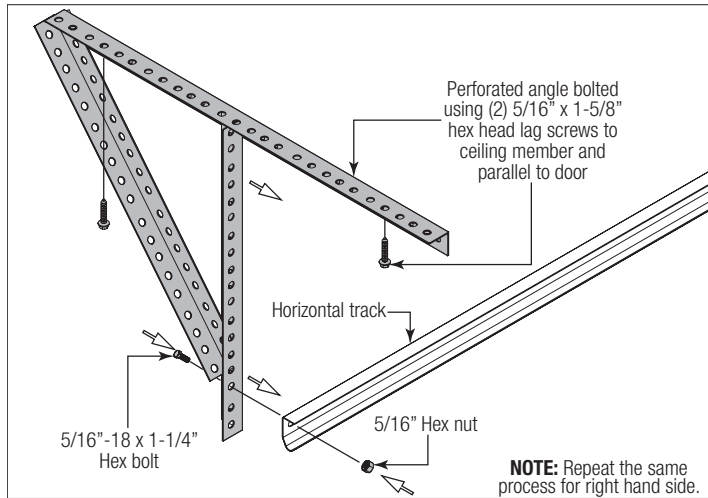
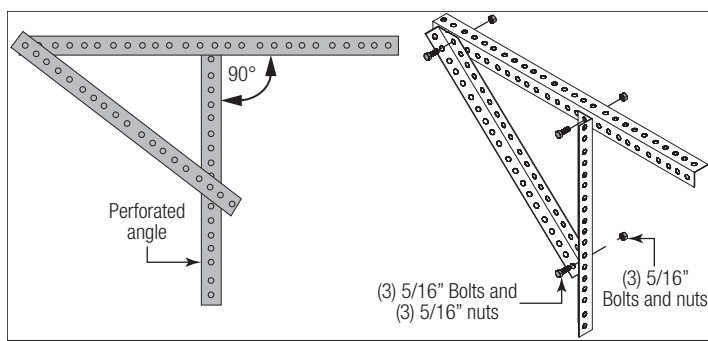

## 25 Attaching Weather Seal

Permanently attach the weatherstrips on both door jambs and header. The weatherstrips were temporarily attached in Preparing the Opening, in the pre-installation section of this manual.

**NOTE:** When permanently attaching the weatherstrips to the jambs, avoid pushing the weatherstrips too tightly against the face of door.

**NOTE:** Door not shown for clarity.

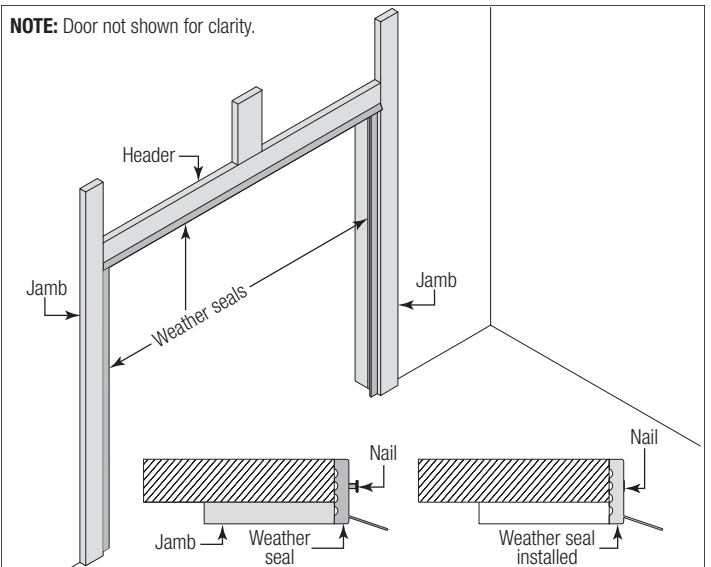

## 26

## Balancing Door

**NOTE:** Windows may cause the top section to be significantly heavier than the remaining sections. Wayne Dalton attempts to balance the door at the top and bottom. To prevent any sudden door acceleration between the top and bottom, we recommend motor operating all doors with windows.

Remove any locking pliers. Lift the door and check its balance. Adjust spring(s) if door lifts by itself (hard to pull down) or if door is difficult to lift (drifts down). Anytime spring adjustments are made, ratchet pawl knob must be in the upper position. An unbalanced door can cause TorqueMaster® Plus operation problems.

Close the door and place locking pliers onto both vertical tracks just above the third track roller. This is to prevent the garage door from rising while adjusting the spring(s).

**IMPORTANT:** TO ADJUST SPRINGS, ONLY ADD OR REMOVE A MAXIMUM OF 3/10 OF A TURN (THREE TEETH ON THE RATCHET WHEEL) AT A TIME. BOTH SIDES NEED TO BE ADJUSTED EQUALLY ON DOUBLE SPRING DOORS.

## ⚠ WARNING

**WINDING SPRINGS IS AN EXTREMELY DANGEROUS PROCEDURE AND SHOULD BE PERFORMED ONLY BY A TRAINED DOOR SYSTEM TECHNICIAN USING PROPER TOOLS AND INSTRUCTIONS.**

**ADD SPRING TENSION:** The ratchet wheel is made of 10 teeth. To add spring tension, tighten counter clockwise on the right hand side and clockwise on the left hand side. Place pawl knob in upper position. Place the ratchet with 5/8" socket and 3" ratchet extension onto the winding shaft, to add 3/10 of a turn. Watch as three teeth of the ratchet wheel pass over the pawl, creating three "clicks". Place pawl knob in lower position. For double spring applications, repeat the same process for the other side.

**REMOVE SPRING TENSION:** To remove spring tension, place a regular 5/8" wrench onto the winding shaft. Place pawl knob in upper position.

**IMPORTANT:** BE PREPARED TO HOLD THE FULL TENSION OF THE SPRING.

Pull down on the wrench to relieve pressure between the pawl and the ratchet wheel. Push in on the pawl to allow the three ratchet wheel teeth to pass by the pawl, as you carefully allow the wrench to be rotated upward by the spring tension, release the pawl to allow it to engage with the ratchet wheel. Place pawl knob in lower position. For double spring applications, repeat the same process for the other side.

**IMPORTANT:** DO NOT ADD OR REMOVE MORE THAN 1 SPRING TURN (1 SPRING TURN EQUALS 10 TEETH ON RATCHET WHEEL) FROM THE RECOMMENDED NUMBER OF TURNS SHOWN ON THE WINDING SPRING TURN CHART.

If the door still does not operate easily, lower the door into the closed position, unwind spring(s) completely, and recheck the following items:

- 1.) Is the door level?
- 2.) Are the TorqueMaster® spring tube and flag angles level and plumb?
- 3.) Does the distance between the flag angles equal door width plus 3-3/8" to 3-1/2"?
- 4.) Do the counterbalance lift cables have equal tension? Adjust if necessary.
- 5.) Rewind the spring(s).
- 6.) Make sure door is not rubbing on jambs.



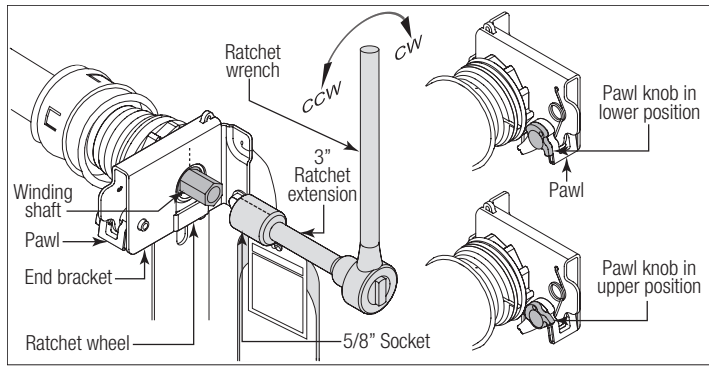

## TorqueMaster® Plus Reset Instructions

**IMPORTANT:** THE DRAWBAR OPERATOR FORCE SETTINGS MUST BE ADJUSTED ACCORDING TO THE MANUFACTURER'S INSTRUCTIONS. SOME LIGHTER WEIGHT DOORS ARE DESIGNED TO OPERATE WITH A SINGLE COUNTERBALANCE SPRING. IF THAT COUNTERBALANCE SPRING BREAKS AND THE DRAWBAR OPERATOR'S FORCE SETTINGS ARE NOT ADJUSTED ACCORDING TO THE MANUFACTURER'S SPECIFICATIONS, THE DRAWBAR OPERATOR MAY THEN HAVE THE CAPABILITY OF LIFTING THE DOOR TO THE OPEN POSITION, DESPITE THE BROKEN COUNTERBALANCE SPRING. THIS SCENARIO WILL CAUSE THE COUNTERBALANCE LIFT CABLES TO GO SLACK AND ENGAGE THE TORQUEMASTER® PLUS SAFETY SYSTEM. IF A PERSON IS UNAWARE OF THE SLACK COUNTERBALANCE LIFT CABLES AND THE ENGAGED TORQUEMASTER® PLUS SAFETY SYSTEM AND ACTIVATES THE MISADJUSTED DRAWBAR OPERATOR, DAMAGE WILL LIKELY OCCUR TO THE DOOR AND DRAWBAR OPERATOR. THE POTENTIAL ALSO EXISTS THAT THE PERSON ACTIVATING THE DRAWBAR OPERATOR UNDER THIS SCENARIO COULD BE SEVERELY INJURED.

### WARNING

READ THESE INSTRUCTIONS CAREFULLY BEFORE ATTEMPTING TO RESET THE TORQUEMASTER® PLUS SYSTEM. IF IN QUESTION ABOUT ANY OF THE PROCEDURES, DO NOT PERFORM THE WORK. INSTEAD, HAVE A QUALIFIED DOOR SYSTEMS TECHNICIAN RESET THE SYSTEM.

### WARNING

TO AVOID SEVERE OR FATAL INJURY, DO NOT STAND OR WALK UNDER A MOVING DOOR, OR PERMIT ANYONE TO STAND OR WALK UNDER AN ELECTRICALLY OPERATED DOOR.

This door is equipped with a TorqueMaster® plus system, a safety feature which prevents the door from rapidly descending in case of spring failure or forceful manual operation. If the system engages with the door in the open position, personal items that are left unattended in the garage or home are at risk to theft. To ensure the safekeeping of these items, close the garage door.

#### Typical signs of an engaged system.

**Single spring system:** Visually inspect the TorqueMaster® Plus right hand end bracket to confirm that the system has engaged (see illustration). If the system is engaged, then the door will not close. If the drawbar operator force settings were properly set during the initial installation, the door will not open. If the drawbar operator can physically overcome the weight of the door and lift it to the open position, then the counterbalance lift cables will be slack. If the system is engaged, DO NOT attempt to make the repairs. Instead, have a trained door system technician make the necessary repairs to counterbalance lift cables, spring assemblies and other hardware.

**Double spring system:** Visually inspect the TorqueMaster® Plus end brackets to confirm that the system has engaged (see illustration). Door makes a distinct "clicking" noise upon being opened. If the system is engaged, carefully follow the reset instructions below or refer to the reset tag (attached to right hand end bracket) to reset the TorqueMaster® Plus system.

#### Resetting an engaged TorqueMaster® Plus double spring system only:

1. First, locate and visually inspect the TorqueMaster® plus end bracket(s) to confirm that the system has engaged (see illustration).
2. With the door in the fully closed position, place locking pliers onto both vertical tracks just above the third track roller. Disengage the drawbar operator (if installed) by pulling or placing the emergency disconnect in the manually operated position.
3. With assistance, carefully remove locking pliers and raise the door to the fully open position.
4. Place locking pliers onto both vertical tracks just below the bottom track roller on both sides.
5. Now is a good time to remove vehicles or personal items from garage to provide clear access to end brackets.
6. For **single spring applications:** Flip the ratchet pawl knob on the right hand end bracket to the upper position. For **double spring applications:** Flip the ratchet pawl knob on both end brackets to the upper position (see illustration).
7. Raise door 2"-3" and then lower door. Repeat this process until the system resets (see disengaged system illustrations).

**IMPORTANT:** BE PREPARED TO SUPPORT THE TOTAL WEIGHT OF THE DOOR.

8. Cautiously remove the locking pliers from the vertical tracks. With assistance lower door.

#### Checking springs for tension:

9. Starting on the right hand side, place a ratchet wrench, 5/8" socket and a 3" extension on the TorqueMaster® Plus winding shaft (see illustration). Ensure ratchet is set so that it will tighten counter clockwise on the right hand side, and clockwise on the left hand side. If tension is present, remove the ratchet and check the left hand side. If spring(s) have tension, the door will need to be balanced; refer to step, Balancing Door, to do this. If no spring tension is present, contact a qualified trained door system technician to replace the spring(s).

**IMPORTANT:** TO AVOID POSSIBLE INJURY, HAVE A TRAINED DOOR SYSTEMS TECHNICIAN MAKE ADJUSTMENTS/ REPAIRS TO COUNTERBALANCE LIFT CABLES, SPRING ASSEMBLIES AND OTHER HARDWARE.

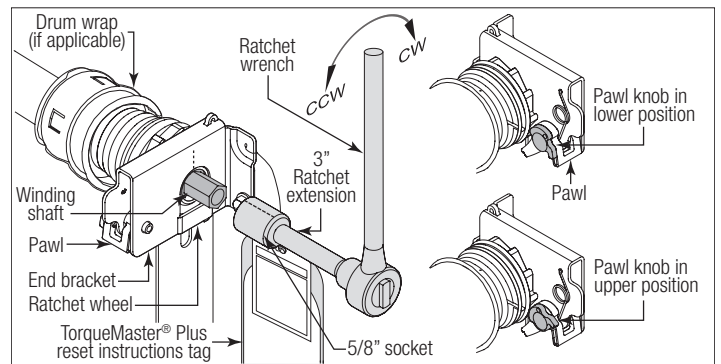
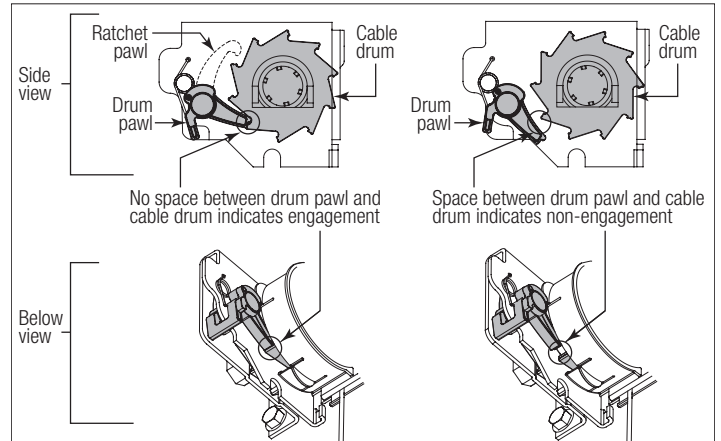

## Inside Lock

Install the inside lock on the second section of the door. Secure the lock to the section with (4) 1/4" - 20 x 11/16" self drilling screws. Square the lock assembly with the door section, and align with the square hole in the vertical track. The inside lock should be spaced approximately 1/8" away from the section edge.

**IMPORTANT:** INSIDE LOCK(S) MUST BE REMOVED OR MADE INOPERATIVE IN THE UNLOCKED POSITION IF AN OPERATOR IS INSTALLED ON THIS DOOR.

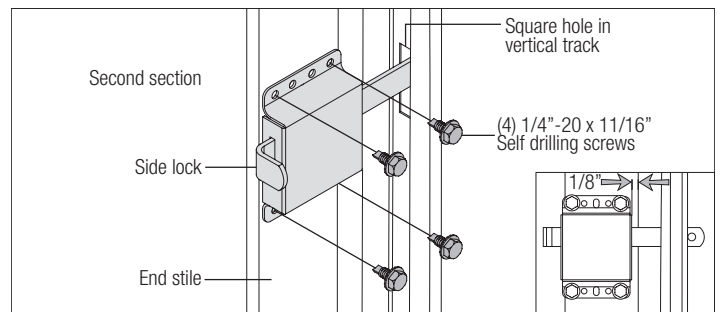

## Pull Down Rope

### WARNING

DO NOT INSTALL PULL DOWN ROPE ON DOORS WITH OPERATORS. CHILDREN MAY BECOME ENTANGLED IN THE ROPE CAUSING SEVERE OR FATAL INJURY.

Measure and mark the jamb approximately 48" to 50" (1220 to 1270 mm) from floor on the right or left side of jamb. Drill 1/8" pilot hole for no. 6 screw eye. Tie the pull down rope to the no. 6 screw eye and to the bottom corner bracket, as shown.

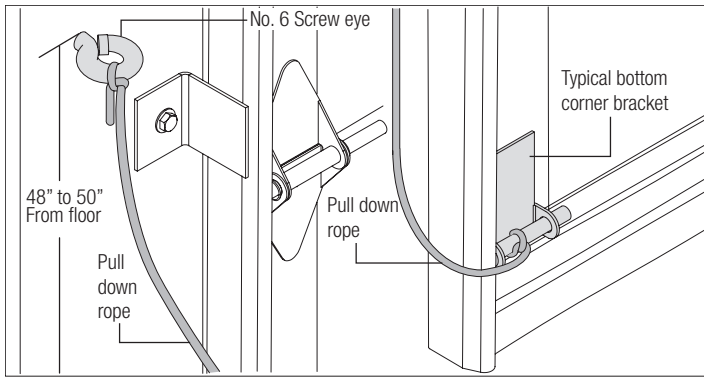

## Cleaning Your Garage Door

**IMPORTANT:** DO NOT USE A PRESSURE WASHER ON YOUR GARAGE DOOR!

While factory-applied finishes on garage doors are durable, it is desirable to clean them on a routine basis. Some discoloration of the finish may occur when a door has been exposed to dirt-laden atmosphere for a period of time. Slight chalking may also occur as a result of direct exposure to sunlight.

Cleaning the door will generally restore the appearance of the finish. To maintain an aesthetically pleasing finish of the garage door, a periodic washing of the garage door is recommended.

**THE FOLLOWING CLEANING SOLUTION IS RECOMMENDED:**

A mild detergent solution consisting of one cup detergent (with less than 0.5% phosphate) dissolved into five gallons of warm water will aid in the removal of most dirt.

**NOTE:** The use of detergents containing greater than 0.5% phosphate is not recommended for use in general cleaning of garage doors.

**NOTE:** Be sure to clean behind weatherstrips on both sides and top of door.

### CAUTION

NEVER MIX CLEANSERS OR DETERGENTS WITH BLEACH.

#### GLASS CLEANING INSTRUCTIONS

Clean with a mild detergent solution (same as above) and a soft cloth. After cleaning, rinse thoroughly.

#### ACRYLIC CLEANING INSTRUCTIONS

Clean acrylic glazing with nonabrasive soap or detergent and plenty of water. Use your bare hands to feel and dislodge any caked on particles. A soft, grit-free cloth, sponge or chamois may be used to wipe the surface. Do not use hard or rough cloths that will scratch the acrylic glazing. Dry glazing with a clean damp chamois.

**NOTE:** Do not use any window cleaning fluids, scouring compounds, gritty cloths or solvent-based cleaners of any kind.

## Painting Your Garage Door

Refer to Instruction Insert “**Field Painting and Finishing Fiberglass or Steel Door Sections**”.

## Maintaining The Finish On Your Garage Door

If the factory finish is beginning to fade, the door may require a field applied top clear coat. Depending on environment and usage, this may be necessary after 1 to 3 years of use. Refer to Instruction Insert “**Field Painting and Finishing Fiberglass Or Steel Door Sections**”.

## Operation And Maintenance

**OPERATING YOUR GARAGE DOOR:** Before you begin, read all warning labels affixed to the door and the installation instructions and owner’s manual. When correctly installed, your Wayne Dalton door will operate smoothly. Always operate your door with controlled movements. Do not slam your door or throw your door into the open position, this may cause damage to the door or its components. If your door has an electric opener, refer to the owner’s manual to disconnect the opener before performing manual door operation below.

**MANUAL DOOR OPERATION:** For additional information on manual garage door operations go to [www.dasma.com](http://www.dasma.com) and reference TDS 165.

### WARNING

DO NOT PLACE FINGERS OR HANDS INTO SECTION JOINTS WHEN OPENING AND/OR CLOSING A DOOR. ALWAYS USE LIFT HANDLES / SUITABLE GRIPPING POINTS WHEN OPERATING THE DOOR MANUALLY.

**OPENING A DOOR:** Make sure the lock(s) are in the unlocked position. Lift the door by using the lift handles / suitable gripping points only. Door should open with little resistance.

**CLOSING A DOOR:** From inside the garage, pull door downward using lift handles / gripping point only. If you are unable to reach the lift handles/ suitable gripping points only, use pull down rope affixed to the side of door. Door should close completely with little resistance.

**USING AN ELECTRIC OPERATOR:**

**IMPORTANT:** PULL DOWN ROPES MUST BE REMOVED AND LOCKS MUST BE REMOVED OR MADE INOPERATIVE IN THE UNLOCKED POSITION.

When connecting a drawbar (trolley type) garage door operator to this door, a drawbar operator bracket must be securely attached to the top section of the door, along with any struts

provided with the door. Always use the drawbar operator bracket supplied with the door. To avoid possible damage to your door, Wayne Dalton recommends reinforcing the top section with a strut (may or may not be supplied). The installation of the drawbar operator must be according to manufacturer’s instructions and force settings must be adjusted properly. Refer to the owner’s manual supplied with your drawbar operator for complete details on installation, operation, maintenance and testing of the operator.

**MAINTAINING YOUR GARAGE DOOR:** Before you begin, read all warning labels affixed to the door and the installation instructions and owner’s manual. Perform routine maintenance steps once a month, and have the door professionally inspected once a year. Review your Installation Instructions and Owner’s Manual for the garage door. These instructions are available at no charge from Wayne Dalton, a division of Overhead Door Corporation, P.O. Box 67, Mt. Hope, OH., 44660, or at [www.Wayne-Dalton.com](http://www.Wayne-Dalton.com). For additional information on garage door/operator maintenance go to [www.dasma.com](http://www.dasma.com) and reference TDS 151, 167 and 179.

**Monthly Inspections:**

**1. Visual Inspection:** Closely inspect jambs, header and mounting surface. Any material found not to be structurally sound must be replaced. It may be necessary to uninstall part or all of the door assembly in order to replace defective material. Refer to the supplemental instructions “Removing an Existing Door / Preparing the Opening” at [www.Wayne-Dalton.com](http://www.Wayne-Dalton.com). Inspect the spring(s), counterbalance lift cables, track rollers, pulleys, rear back hangs and other door hardware for signs of worn or broken parts. Tighten any loose screws and/or bolts, except on bottom corner brackets or on the counterbalance assembly. Check exterior surface of the door sections for any minor cracks. Verify door has not shifted right or left in the opening. If you suspect problems, contact a trained door system technician.

### WARNING

**GARAGE DOOR SPRINGS, COUNTERBALANCE LIFT CABLES, BRACKETS, AND OTHER HARDWARE ATTACHED TO THE SPRINGS ARE UNDER EXTREME TENSION, AND IF HANDLED IMPROPERLY, CAN CAUSE SEVERE OR FATAL INJURY. ONLY A TRAINED DOOR SYSTEMS TECHNICIAN SHOULD ADJUST THEM, BY CAREFULLY FOLLOWING THE MANUFACTURER’S INSTRUCTIONS.**

### WARNING

**NEVER REMOVE, ADJUST, OR LOOSEN THE BOLTS, SCREWS AND/OR LAG SCREWS ON THE COUNTERBALANCE (END BEARING BRACKETS, DRUMS OR SPRING SYSTEM) OR BOTTOM CORNER BRACKETS OF THE DOOR. THESE BRACKETS ARE CONNECTED TO THE SPRING(S) AND ARE UNDER EXTREME TENSION. TO AVOID POSSIBLE SEVERE OR FATAL INJURY, HAVE ANY SUCH WORK PERFORMED BY A TRAINED DOOR SYSTEMS TECHNICIAN USING PROPER TOOLS AND INSTRUCTIONS.**

**TORQUEMASTER® PLUS SPRINGS:** Pawl knob(s) (located on the TorqueMaster® end brackets above the door) should be engaged to prevent the door from rapidly descending in case of spring failure or forceful manual operation.

**EXTENSION SPRINGS:** A restraining cable or other device should be installed on the extension spring (located above the horizontal tracks) to help contain the spring if it breaks.

**2. Door Balance:** Periodically test the balance of your door. If you have a garage door drawbar operator, use the release mechanism so you can operate the door by hand when doing this test. Start with the door in the fully closed position. Using handles or suitable gripping points, lift the door to check its balance. Adjust TorqueMaster® or Extension spring(s), if door lifts by itself (hard to pull down) or if door is difficult to lift (easy to pull down). DO NOT attempt to repair or adjust Torsion Springs yourself. To adjust TorqueMaster® or Extension spring(s), refer to your installation instructions and owner’s manual. If in question about any of the procedures, do not perform the work. Instead, have it adjusted by a trained door systems technician.

**3. Lubrication:** The door should open and close smoothly. Ensure the door track rollers are rotating freely when opening and closing the door. If track rollers do not rotate freely, clean the door tracks, removing dirt and any foreign substances. Clean and lubricate (use a non-silicon based lubricant) graduated end hinges, center hinges, steel track rollers, bearings and torsion springs (torsion spring coil surfaces). DO NOT lubricate plastic idler bearings, nylon track rollers, door track. DO NOT oil a cylinder lock, if actuation is difficult use a graphite dust to lubricate.

**CHECK FOR PRESENCE OF SAFETY LABELS:**

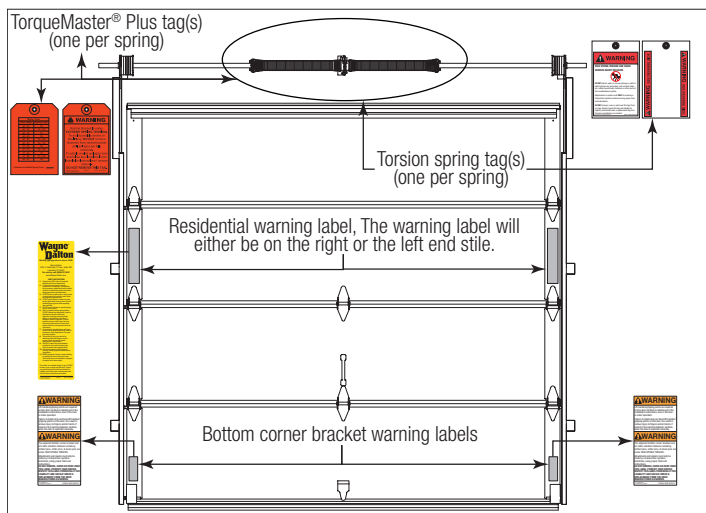

**Limited Warranty  
Models 8000, 8100, 8200**

Wayne Dalton, a division of Overhead Door Corporation (“Seller”) warrants to the original purchaser of the Models 8000, 8100, 8200 (“Product”), subject to all of the terms and conditions hereof, that the Product and all components thereof will be free from defects in materials and workmanship for the following period(s) of time, measured from the date of installation:

**TEN (10) YEARS** from the date of installation against:

- The Product becoming inoperable due to rust-through of the steel skin from the core of the Product section, due to cracking, splitting, or other deterioration of the steel skin, or due to structural failure caused by separation or degradation of the foam insulation.
- Peeling of the original paint as a result of a defect in the original paint or in the application of the original paint coating.

**TEN (10) YEARS** on Product hardware and tracks (except springs).

**ONE (1) YEAR** on all other component and parts.

Seller’s obligation under this warranty is specifically limited to repairing or replacing, at its option, any part which is determined by Seller to be defective during the applicable warranty period. Any labor charges are excluded and will be the responsibility of the purchaser.

This warranty gives you specific legal rights, and you may also have other rights which vary from state to state. This warranty is made to the original purchaser of the Product only, and is not transferable or assignable. This warranty applies only to Product installed in a residential or other non-commercial application. It does not cover any Product installed in commercial or industrial building applications. This warranty does not apply to any unauthorized alteration or repair of the Product, or to any Product or component which has been damaged or deteriorated due to misuse, neglect, accident, failure to provide necessary maintenance, normal wear and tear, acts of God, or any other cause beyond the reasonable control of Seller or as a result of having been exposed to toxic or abrasive environments, including blowing sand, salt water, salt spray and toxic chemicals and fumes.

ALL EXPRESS AND IMPLIED WARRANTIES FOR THE PRODUCT, INCLUDING BUT NOT LIMITED TO ANY IMPLIED WARRANTIES OF MERCHANTABILITY AND FITNESS FOR A PARTICULAR PURPOSE, ARE LIMITED IN TIME TO THE APPLICABLE WARRANTY PERIOD REFLECTED ABOVE. NO WARRANTIES, WHETHER EXPRESS OR IMPLIED, WILL APPLY AFTER THE LIMITED WARRANTY PERIOD HAS EXPIRED. Some states do not allow limitations on how long an implied warranty lasts, so the above limitation may not apply to you.

IN NO EVENT SHALL SELLER BE RESPONSIBLE FOR, OR LIABLE TO ANYONE FOR, SPECIAL, INDIRECT, COLLATERAL, PUNITIVE, INCIDENTAL OR CONSEQUENTIAL DAMAGES, even if Seller has been advised of the possibility of such damages. Such excluded damages include, but are not limited to, loss of use, cost of any substitute product, or other similar indirect financial loss. Some states do not allow the exclusion or limitation of incidental or consequential damages, so the above limitation or exclusion may not apply to you.

Claims under this warranty must be made promptly after discovery, within the applicable warranty period, and in writing to the authorized distributor or installer whose name and address appear below. The purchaser must allow Seller a reasonable opportunity to inspect any Product claimed to be defective prior to removal or any alteration of its condition. Proof of the purchase and/or installation date, and identification as the original purchaser, may be required. There are no established informal dispute resolution procedures of the type described in the Magnuson-Moss Warranty Act.

• SELLER: \_\_\_\_\_

• SELLER’S ADDRESS: \_\_\_\_\_

\_\_\_\_\_



---

Thank you for your purchase.

---

**PLEASE DO NOT RETURN THIS PRODUCT TO THE STORE**

If you need assistance, please call 1-866-569-3799 (press Option 1) and follow the prompts to contact a customer service representative. They will be happy to handle any questions that you may have.

---

After installation is complete, leave this Installation Instructions And Owner's Manual with the homeowner, or fasten it near garage door for easy reference.