

Models 8000 / 8100 / 8200

TORSION

RESIDENTIAL AND LIGHT COMMERCIAL
STANDARD LIFT

INSTALLATION INSTRUCTIONS AND OWNER'S MANUAL

DEFINITION OF LIGHT COMMERCIAL:

1. Door Heights less than or equal to 8'0" ($\leq 8'0"$) are considered Residential Applications.
2. Door Heights greater than 8'0" ($> 8'0"$) are considered Light Commercial Applications.

PLEASE DO NOT RETURN THIS PRODUCT TO THE STORE

If you need assistance, please call 1-866-569-3799 (press Option 1) and follow the prompts to contact a customer service representative. They will be happy to handle any questions that you may have.

Table Of Contents

Pre-Installation	2
Important Safety Instructions	2
Removing an Existing Door and Preparing the Opening	2
Package Contents	3
Door Section Identification	4
Tools Required	5
Breakdown Of Parts	6
Door Installation Instructions	7
Counterbalance Installation Instructions	12
Optional Installation	18
Inside Lock	18
Pull Down Rope	18
Maintenance	19
Cleaning Your Garage Door	19
Painting Your Garage Door	19
Maintaining The Finish On Your Garage Door	19
Operation And Maintenance	19
Warranty	21

IMPORTANT NOTICES!

To avoid possible injury, read and fully understand the enclosed instructions carefully before installing and operating the garage door. Pay close attention to all warnings and notes. After installation is complete, fasten this manual near garage door for easy reference.

This Installation document is available at no charge from:

- Your local Wayne Dalton Sales Center, or
- Online at www.Wayne-Dalton.com, or
- By mailing to: Wayne Dalton, a division of Overhead Door Corporation, P.O. Box 67, Mt. Hope, OH., 44660

Important Safety Instructions

DEFINITION OF KEY WORDS USED IN THIS MANUAL:

WARNING

INDICATES A POTENTIALLY HAZARDOUS SITUATION WHICH, IF NOT AVOIDED, COULD RESULT IN SEVERE OR FATAL INJURY.

CAUTION

PROPERTY DAMAGE OR INJURY CAN RESULT FROM FAILURE TO FOLLOW INSTRUCTIONS.

IMPORTANT: REQUIRED STEP FOR SAFE AND PROPER DOOR OPERATION.

NOTE: Information assuring proper installation of the door.

READ THESE INSTRUCTIONS CAREFULLY BEFORE ATTEMPTING INSTALLATION. IF IN QUESTION ABOUT ANY OF THE PROCEDURES, DO NOT PERFORM THE WORK. INSTEAD, HAVE A TRAINED DOOR SYSTEMS TECHNICIAN DO THE INSTALLATION OR REPAIRS.

1. READ AND FOLLOW ALL INSTALLATION INSTRUCTIONS.
2. Wear protective gloves during installation to avoid possible cuts from sharp metal edges.
3. It is always recommended to wear eye protection when using tools, otherwise eye injury could result.
4. Avoid installing your new door on windy days. Door could fall during the installation causing severe or fatal injury.
5. Doors 12'-0" wide and over should be installed by two persons, to avoid possible injury.
6. Operate door only when it is properly adjusted and free from obstructions.
7. If a door becomes hard to operate, inoperative or is damaged, immediately have necessary adjustments and/ or repairs made by a trained door system technician using proper tools and instructions.
8. DO NOT stand or walk under a moving door, or permit anybody to stand or walk under an electrically operated door.
9. DO NOT place fingers or hands into open section joints when closing a door. Use lift handles/ gripping points when operating door manually.
10. DO NOT permit children to operate garage door or door controls. Severe or fatal injury could result should the child become entrapped between the door and the floor.
11. Due to constant extreme spring tension, do not attempt any adjustment, repair or alteration to any part of the door, especially to springs, spring brackets, bottom corner brackets, fasteners, counterbalance lift cables or supports. To avoid possible severe or fatal injury, have any such work performed by a trained door systems technician using proper tools and instructions.
12. On electrically operated doors, pull down ropes must be removed and locks must be removed or made inoperative in the open (unlocked) position.
13. Top section of door may need to be reinforced when attaching an electric opener. Check door and/ or opener manufacturer's instructions.
14. Visually inspect door and hardware monthly for worn and or broken parts. Check to ensure door operates freely.
15. Test electric opener's safety features monthly, following opener manufacturer's instructions.
16. NEVER hang tools, bicycles, hoses, clothing or anything else from horizontal tracks. Track systems are not intended or designed to support extra weight.
17. This door may not meet the building code wind load requirements in your area. For your safety, you will need to check with your local building official for wind load code requirements and building permit information.
18. For windloaded doors, the wind performance is achieved via the entire door system and component substitution is not authorized without express permission by Wayne Dalton.

NOTE: It is recommended that 5/16" lag screws are pilot drilled using a 3/16" drill bit, prior to fastening.





CAUTION

IF ANY PART OF THE DOOR IS TO BE INSTALLED ONTO PRESERVATIVE-TREATED WOOD, PTFE-COATED OR STAINLESS STEEL FASTENERS MUST BE OBTAINED AND USED. REPLACEMENT FASTENERS MUST BE OF AT LEAST EQUAL STRENGTH AND SIZE AS ORIGINAL FASTENERS. IF THE ORIGINAL FASTENER WAS RED-HEAD, THE REPLACEMENT FASTENER MUST BE RED-HEAD ALSO. CONTACT WAYNE DALTON FOR FASTENER STRENGTH VALUES IF NEEDED.

WARNING

IMPACT GUNS ARE NOT RECOMMENDED. WHEN INSTALLING 5/16" LAG SCREWS USING AN ELECTRIC DRILL/ DRIVER, THE DRILL/ DRIVERS CLUTCH MUST BE SET TO DELIVER NO MORE THAN 200 IN-LBS OF TORQUE. FASTENER FAILURE COULD OCCUR AT HIGHER SETTINGS.

IMPORTANT: RIGHT AND LEFT HAND IS DETERMINED INSIDE THE BUILDING LOOKING OUT.

Potential Hazard	Effect	Prevention
 <p>Moving door</p>	 WARNING Could result in Death or Serious Injury	Keep people clear of opening while Door is moving. Do NOT allow children to play with the Door Opener. Do NOT operate a Door that jams or one that has a broken spring.
 <p>High tension spring</p>	 WARNING Could result in Death or Serious Injury	Do NOT try to remove, install, repair or adjust springs or anything to which door spring parts are fastened, such as, wood blocks, steel brackets, cables or other like items. Installations, repairs and adjustments must be done by a trained door system technician using proper tools and instructions.

Removing an Existing Door and Preparing the Opening

IMPORTANT: COUNTERBALANCE SPRING TENSION MUST ALWAYS BE RELEASED BEFORE ANY ATTEMPT IS MADE TO START REMOVING AN EXISTING DOOR.

WARNING

A POWERFUL SPRING RELEASING ITS ENERGY SUDDENLY CAN CAUSE SEVERE OR FATAL INJURY. TO AVOID INJURY, HAVE A TRAINED DOOR SYSTEMS TECHNICIAN, USING PROPER TOOLS AND INSTRUCTIONS, RELEASE THE SPRING TENSION.

To avoid possible injury and to insure proper installation, it's highly recommended that you read and fully understand the complete instructions on removing an Existing Door & Preparing the Opening. These are available for download at www.Wayne-Dalton.com or at your local Wayne Dalton Sales Center.

IMPORTANT: IF YOU JUST REMOVED YOUR EXISTING DOOR OR YOU ARE INSTALLING A NEW DOOR, COMPLETE ALL STEPS IN PREPARING THE OPENING.

To ensure secure mounting of track brackets, side and spring anchor brackets, or steel angles to new or retro-fit construction, it is recommended to follow the procedures outlined in DASMA technical data sheets #156, #161 and #164 at www.dasma.com.

The inside perimeter of your garage door opening should be framed with wood jamb and header material. The jambs and header must be securely fastened to sound framing members. It is recommended that 2" x 6" lumber be used. The jambs must be plumb and the header level. The jambs should extend a minimum of 12" (305 mm) above the top of the opening for TorqueMaster® counterbalance systems. For low headroom applications, the jambs should extend to the ceiling height. Minimum side clearance required, from the opening to the wall, is 3-1/2" (89 mm).

IMPORTANT: CLOSELY INSPECT JAMBS, HEADER AND MOUNTING SURFACE. ANY WOOD FOUND NOT TO BE SOUND, MUST BE REPLACED.

For TorqueMaster® counterbalance systems, a suitable mounting surface (2" x 6") must be firmly attached to the wall, above the header at the center of the opening.

NOTE: Drill a 3/16" pilot hole in the mounting surface to avoid splitting the lumber. Do not attach the mounting surface with nails.

WEATHERSTRIPS (MAY NOT BE INCLUDED):

Depending on the size of your door, you may have to cut or trim the weatherstrips (if necessary) to properly fit into the header and jambs.

NOTE: If nailing product at 40°F or below, pre-drilling is required.

NOTE: Do not permanently attach weatherstrips to the header and jambs at this time.

For the header, align the weatherstrip 1/8" to 1/4" inside the header edge, and temporarily secure it to the header with equally spaced nails. Starting at either side of the jamb, fit the weatherstrip up tight against the temporarily attached weatherstrip in the header and 1/8" to 1/4" inside the jamb edge. Temporarily secure the weatherstrip with equally spaced nails. Repeat for other side. This will keep the bottom section from falling out of the opening during installation. Equally space nails approximately 12" to 18" apart.

HEADROOM REQUIREMENT: Headroom is defined as the space needed above the top of the door for tracks, springs, etc. to allow the door to open properly. If the door is to be motor operated, 2-1/2" (64 mm) of additional headroom is required.

NOTE: 6" low headroom conversion kit is available for 12" radius only. Contact your local Wayne Dalton dealer.

BACKROOM REQUIREMENT: Backroom is defined as the distance needed from the opening back into the garage to allow the door to open fully.

***NOTE:** For door heights from 10'1" to 14'0", refer to your operator manufacture installation instructions for appropriate depth into room.

BACKROOM REQUIREMENTS

Door Height	Track	Manual Lift	Motor Operated
6'0" to 7'0"	12", 14" Radius	102" (2591 mm)	125" (3175 mm)
7'1" to 8'0"	12", 14" Radius	114" (2896 mm)	137" (3480 mm)
8'1" to 9'0"	12", 14" Radius	126" (3200 mm)	168" (4267 mm)
9'1" to 10'0"	12", 14" Radius	138" (3505 mm)	168" (4267 mm)
10'1" to 12'0"	12", 14" Radius	162" (4115 mm)	See *NOTE
12'1" to 14'0"	12", 14" Radius	186" (4724 mm)	See *NOTE

HEADROOM REQUIREMENTS

Track Type	Space Needed
12" Radius	13-1/2" (343 mm)
14" Radius	14-1/2" (368 mm)

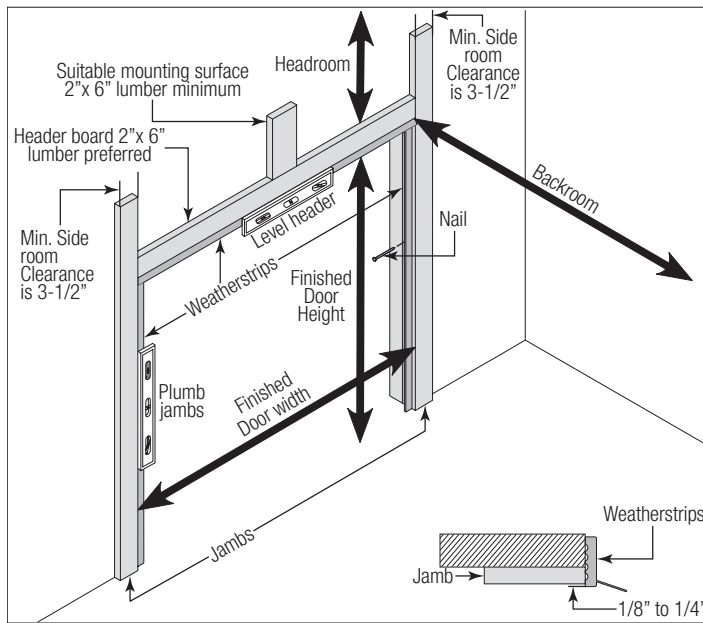

Package Contents

NOTE: Depending on the door model, some parts listed will not be supplied if not required. Rear Back Hangs may not be included with your door.

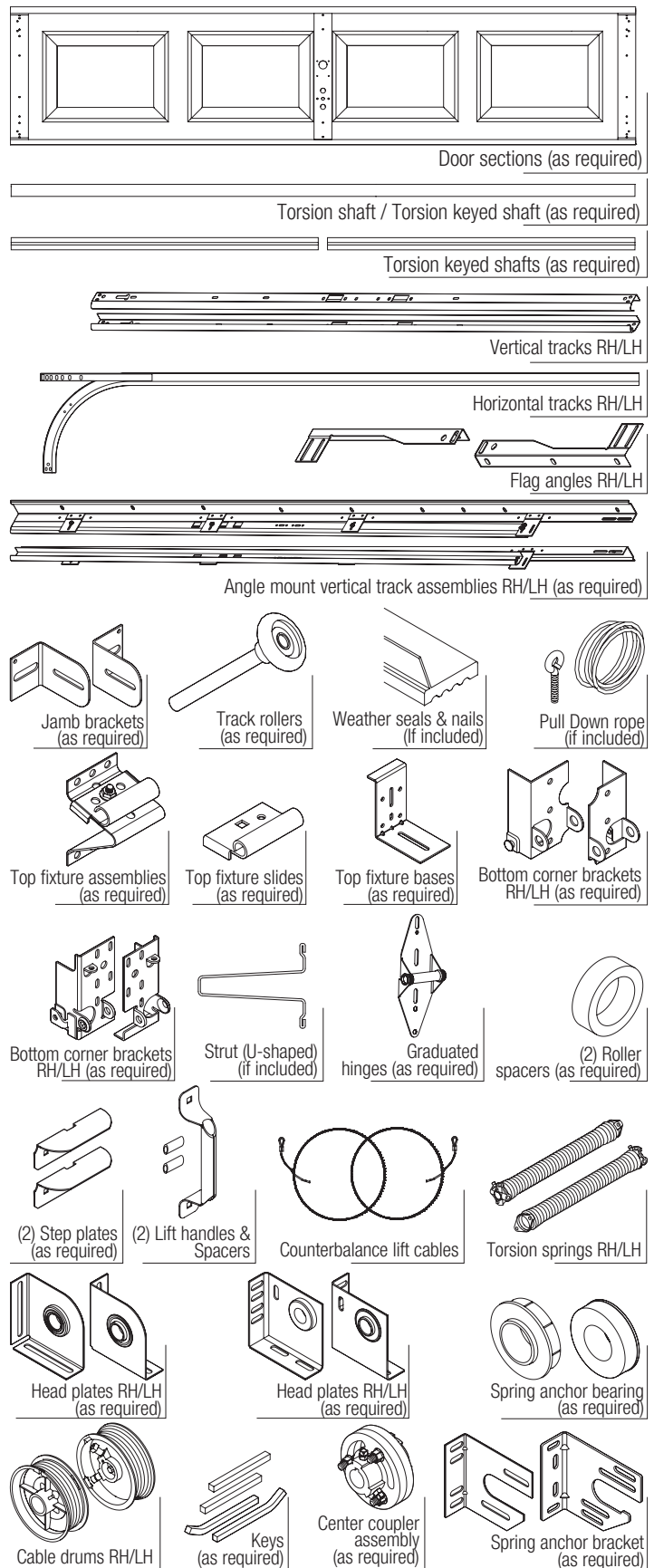

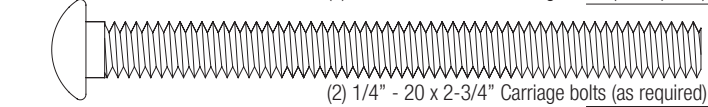
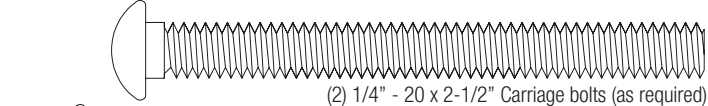
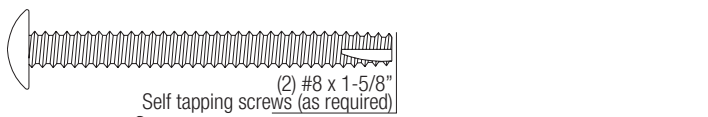
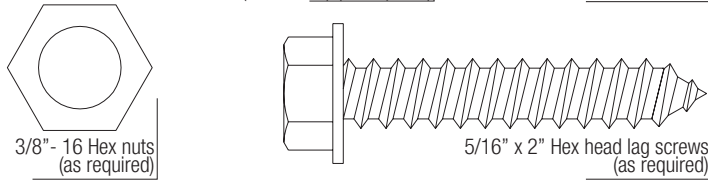
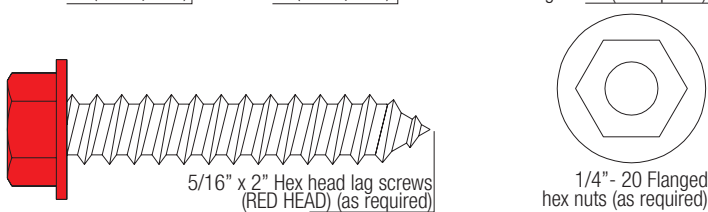
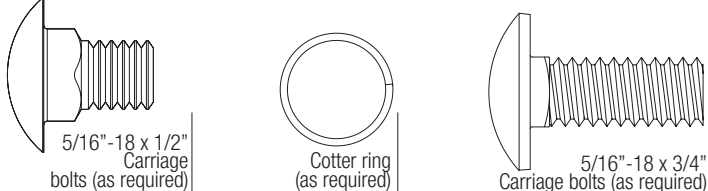
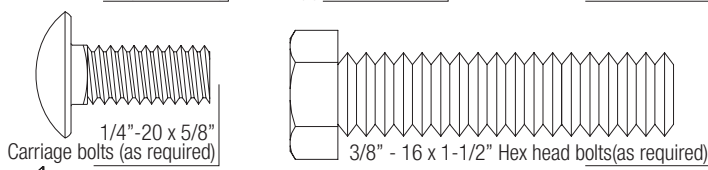
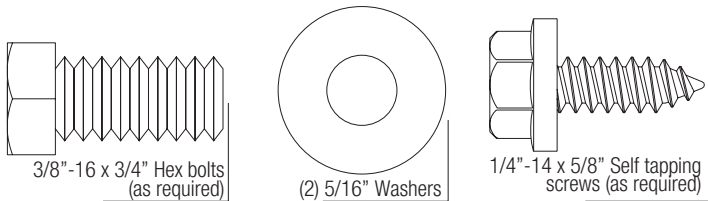
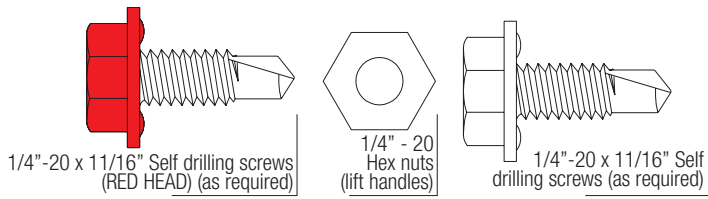

Door Section Identification

Door Section Identification								
Door Height	Section Type							
	Bottom	Lock (second)	Intermediate I (third)	Intermediate II (fourth)	Intermediate III (fifth)	Intermediate IV (sixth)	Intermediate V (seventh)	Top

Door Section Identification								
6'0"	18"	18"	18"	N/A				18"
6'3"	21"	18"	18"	N/A				18"
6'6"	21"	18"	18"	N/A				21"
6'9"	21"	21"	21"	N/A				18"
7'0"	21"	21"	21"	N/A				21"
7'6"	18"	18"	18"	18"	N/A			18"
7'9"	21"	18"	18"	18"	N/A			21"
8'0"	21"	18"	18"	18"	N/A			21"
8'3"	21"	21"	18"	18"	N/A			21"
8'6"	21"	21"	21"	21"	N/A			18"
8'9"	21"	21"	21"	21"	N/A			21"
9'0"	18"	18"	18"	18"	18"	N/A		18"
9'3"	21"	18"	18"	18"	18"	N/A		18"
9'6"	21"	18"	18"	18"	18"	N/A		21"
9'9"	21"	21"	18"	18"	18"	N/A		21"
10'0"	21"	21"	21"	18"	18"	N/A		21"
10'3"	21"	21"	21"	21"	21"	N/A		18"
10'6"	21"	21"	21"	21"	21"	N/A		21"
10'9"	21"	18"	18"	18"	18"	18"	N/A	18"
11'0"	21"	18"	18"	18"	18"	18"	N/A	21"
11'3"	21"	21"	18"	18"	18"	18"	N/A	21"
11'6"	21"	21"	21"	18"	18"	18"	N/A	21"
11'9"	21"	21"	21"	21"	18"	18"	N/A	21"
12'0"	21"	21"	21"	21"	21"	21"	N/A	18"
12'3"	21"	21"	21"	21"	21"	21"	N/A	21"
12'6"	21"	18"	18"	18"	18"	18"	18"	21"
12'9"	21"	21"	18"	18"	18"	18"	18"	21"
13'0"	21"	21"	21"	18"	18"	18"	18"	21"
13'3"	21"	21"	21"	21"	18"	18"	18"	21"
13'5"	21"	21"	21"	21"	21"	18"	18"	21"
13'8"	21"	21"	21"	21"	21"	21"	21"	18"
13'11"	21"	21"	21"	21"	21"	21"	21"	21"

When installing your door you must use sections of the appropriate height in the right stacking order. What section heights you need to use in what order depends on the height of your door.

Unless your door is five sections in height, you will not receive an Intermediate II section.

The **BOTTOM SECTION** can be identified by the factory attached bottom astragal, the factory attached bottom corner brackets, and by the bottom corner bracket warning labels on each end stile.

The **INTERMEDIATE I SECTION** may have a warning label attached to either right or left hand end stile of the section. This section is always the 3rd section from the bottom of the door.

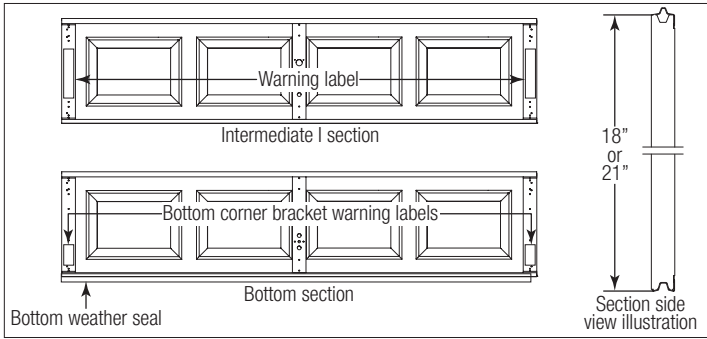

Tools Required

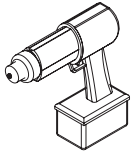

Power drill

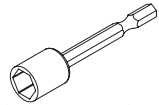

Socket driver: 7/16"



Drill bits: 1/8", 3/16",
9/32", 7/16", 1/2"

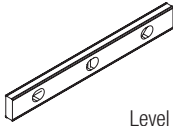

Level



Ratchet wrench

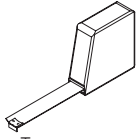

Tape measure

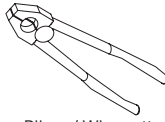

Pliers / Wire cutters

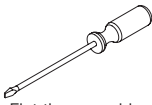

Flat tip screwdriver



Phillips head screwdriver



Wrenches: 3/8", 7/16",
1/2", 9/16", 5/8"



3" Ratchet
extension



Sockets: 7/16",
1/2", 9/16", 5/8"

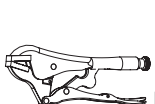

Vise clamps



Hammer



Step ladder

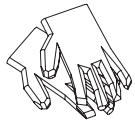

Leather gloves

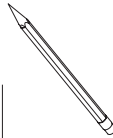

Pencil

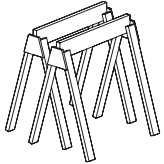

Saw horses



Safety glasses



Approved winding bars

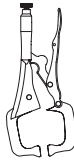

Locking pliers

BREAKDOWN OF PARTS

NOTE: The illustrations shown on this page are general representations of the door parts. Each specific door models may have unique variations.

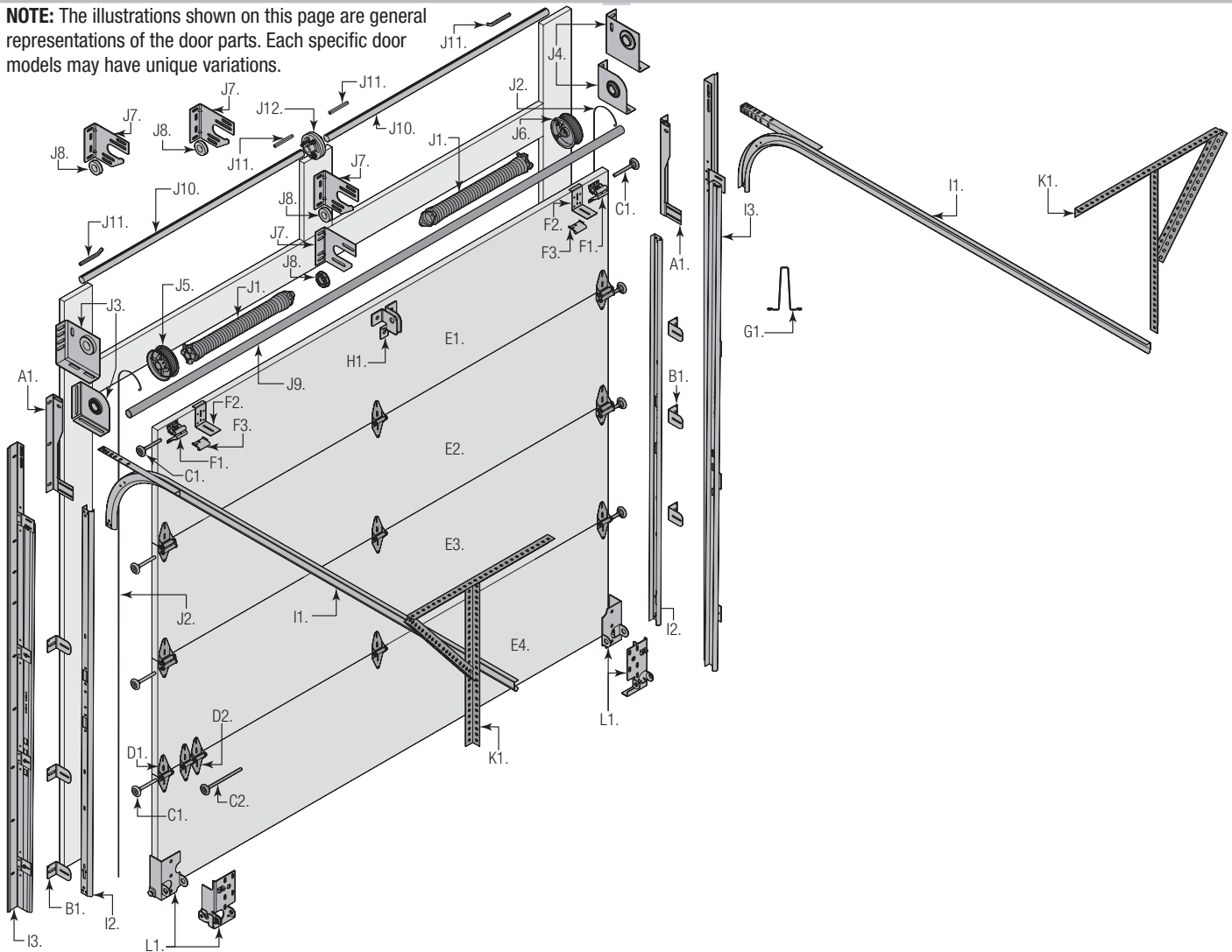

A. FLAG ANGLES (AS REQUIRED):

A1. Fully Adjustable (F.A.) Flag Angles

B. JAMB BRACKETS (AS REQUIRED):

B1. Fully Adjustable (F.A.) Jamb Brackets

C. TRACK ROLLERS (AS REQUIRED):

C1. Short Stem Track Rollers
C2. Long Stem Track Rollers

D. GRADUATED END HINGES:

D1. Single Graduated End Hinges (S.E.H.), Industry Standard
D2. Double Graduated End Hinges (D.E.H.), Industry Standard

E. STACKED SECTIONS:

E1. Top Section
E2. Intermediate(s) Section
E3. Lock Section
E4. Bottom Section

F. TOP FIXTURES (AS REQUIRED):

F1. Top Fixture Assemblies
F2. Top Fixture Bases
F3. Top Fixture Slides

G. STRUT(S) (AS REQUIRED):

G1. Strut (U - shaped)

H. DRAWBAR OPERATOR BRACKET (FOR TROLLEY OPERATED DOORS):

H1. Drawbar Operator Bracket (Supplied By Others)

I. TRACKS (AS REQUIRED):

I1. Left Hand and Right Hand Horizontal Track Assemblies
I2. Left Hand and Right Hand Vertical Tracks
I3. Left Hand and Right Hand Angle Mount Vertical Track Assemblies

J. TORSION SPRING ASSEMBLY (AS REQUIRED):

J1. Left Hand and Right Hand Torsion Springs (As Required)
J2. Counterbalance Lift Cables
J3. Left Hand Head Plate (As Required)
J4. Right Hand Head Plate (As Required)
J5. Left Hand Cable Drum
J6. Right Hand Cable Drum
J7. Spring Anchor Bracket (As Required)
J8. Spring Anchor Bearing (As Required)
J9. Torsion Shaft / Torsion Keyed Shaft (As Required)
J10. Torsion Keyed Shafts (As Required)
J11. Keys (As Required)
J12. Center Coupler Assembly (As Required)

K. REAR BACK HANGS:

K1. Left Hand And Right Hand Rear Back Hang Assemblies

L. BOTTOM CORNER BRACKETS (AS REQUIRED):

L1. Left Hand and Right Hand Bottom Corner Bracket

DOOR INSTALLATION INSTRUCTIONS

Before installing your door, be certain that you have read and followed all of the instructions covered in the pre-installation section of this manual. Failure to do so may result in an improperly installed door.

NOTE: Reference TDS 160 for general garage door terminology at www.dasma.com.

IMPORTANT: IF THE DOOR WILL BE EXPOSED TO A SIGNIFICANT AMOUNT OF ROAD SALT, PAINT THE BARE GALVANIZED BOTTOM WEATHER STEEL RETAINER TO INHIBIT RUSTING.

1 Preparing Vertical Tracks

NOTE: If you have a wall angle track assembly, skip this step.

NOTE: Refer to Door Section Identification / Parts Breakdown Of Parts, to determine if you have vertical tracks.

Vertical tracks may or may not have to be cut to the proper length, prior to installing.

IMPORTANT: VERTICAL TRACKS ARE NOT REQUIRED TO BE CUT DOWN IF YOU HAVE DOOR HEIGHTS 7'-0" OR 8'-0".

Determine the radius of your horizontal track.

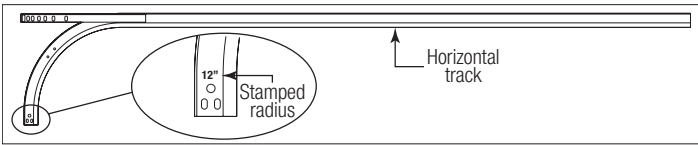

Refer to the vertical track cutting chart to determine the length needed to be cut off at the top of the vertical tracks. Using this measurement, measure and cut the vertical track off at the top, as shown. Remove any burrs from the cut edge of vertical track.

Vertical Track Cutting Chart

Horizontal Track Radius	Vertical Track Cut Length
10" Or 12" Radius	Door Height Minus 10"
14" Radius	Door Height Minus 8"

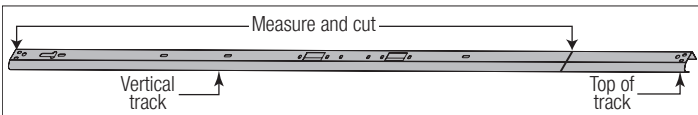

Now, two holes must be drilled into the top of the cut vertical track. Using the illustration shown below, mark and drill the hole locations using a 5/16" drill bit. Once the holes have been drilled, remove any burrs from the drilled holes. Repeat the same process for the other vertical track.

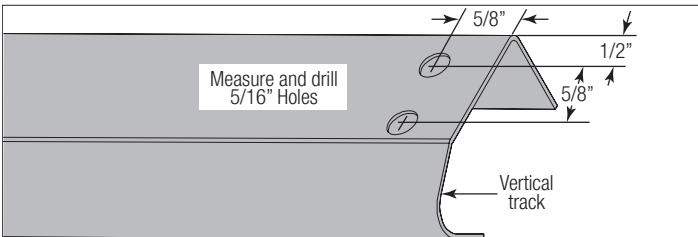

2 Attaching Flag Angles and Jamb Brackets To Vertical Tracks

Hand tighten the left hand flag angle to the left hand vertical track using (2) 1/4" - 20 x 5/8" carriage bolts and (2) 1/4" - 20 flange hex nuts.

NOTE: The bottom jamb bracket is always the shortest bracket, while the center jamb bracket is the next tallest. If three jamb brackets per side are included with your door, you will have received a top jamb bracket, which is the tallest.

To attach the bottom jamb bracket, locate lower hole of the hole/ slot pattern of the 1st hole set on the vertical track. Align the slot in the jamb bracket with the lower hole of the hole/ slot pattern. Hand tighten jamb bracket using (1) 1/4" - 20 x 5/8" carriage bolt and (1) 1/4" - 20 flange hex nut.

Place the center jamb bracket over the lower hole of the hole/ slot pattern that is centered between the bottom jamb bracket and flag angle of the 2nd hole set. Hand tighten jamb bracket using (1) 1/4" - 20 x 5/8" carriage bolt and (1) 1/4" - 20 flange hex nut.

If a top jamb bracket was included, hand tighten it to vertical track using the lower hole of the hole/ slot pattern in the 3rd hole set and (1) 1/4" - 20 x 5/8" carriage bolt and (1) 1/4" - 20 flange hex nut.

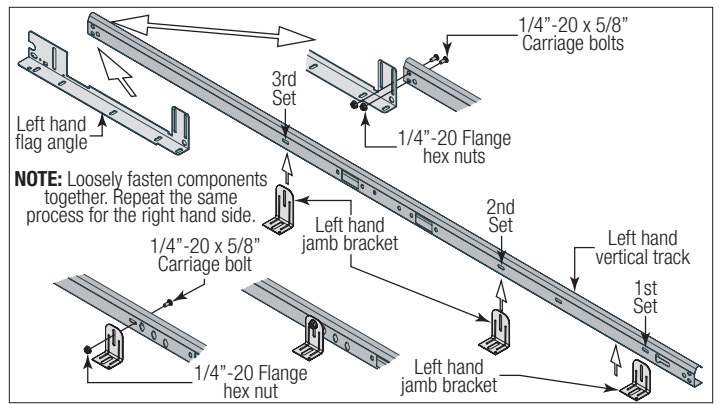

NOTE: Loosely fasten components together. Repeat the same process for the right hand side.

3 Attaching Bottom Corner Brackets

NOTE: Refer to door section identification, located in the pre-installation section of this manual or refer to Breakdown Of Parts.

Uncoil the counterbalance lift cables. Depending on which bottom corner brackets you have, either slip the loop at the ends of the counterbalance lift cable over the milford pin of the bottom corner bracket or secure the cable loop to the clevis pin and bottom corner bracket using a 5/16" flat washer and a cotter pin. Repeat for other bottom corner bracket.

WARNING

ENSURE TIGHT FIT OF CABLE LOOP OVER MILFORD PIN TO PREVENT COUNTERBALANCE LIFT CABLE FROM COMING OFF THE PIN, WHICH COULD ALLOW THE DOOR TO FALL AND RESULT IN SEVERE OR FATAL INJURY.

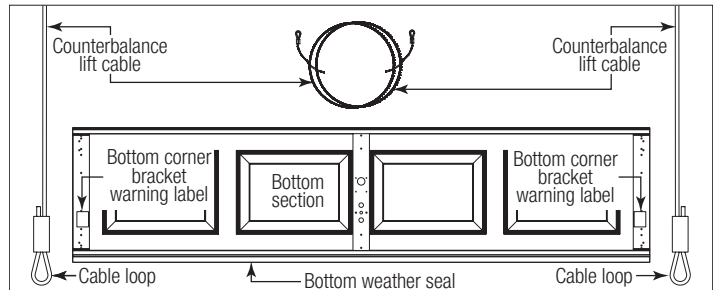

Position the left hand bottom corner bracket onto the bottom section. Attach the bottom corner bracket to the bottom section with (3) 1/4" - 20 x 11/16" RED HEAD self drilling screws and if applicable two more 1/4" - 20 x 11/16" self drilling screws. Repeat same process for the right hand side.

IMPORTANT: THE 1/4" - 20 X 11/16" RED HEAD SELF DRILLING SCREWS MUST BE MUST BE INSTALLED THROUGH THE HOLES OF THE BOTTOM CORNER BRACKETS, AS SHOWN.

Insert a short stem track roller with a roller spacer (if applicable) into the bottom corner bracket. Repeat for other side.

NOTE: Verify bottom weather seal is aligned with bottom section. If there is more than 1/2" excess weather seal on either side, trim weather seal even with bottom section.

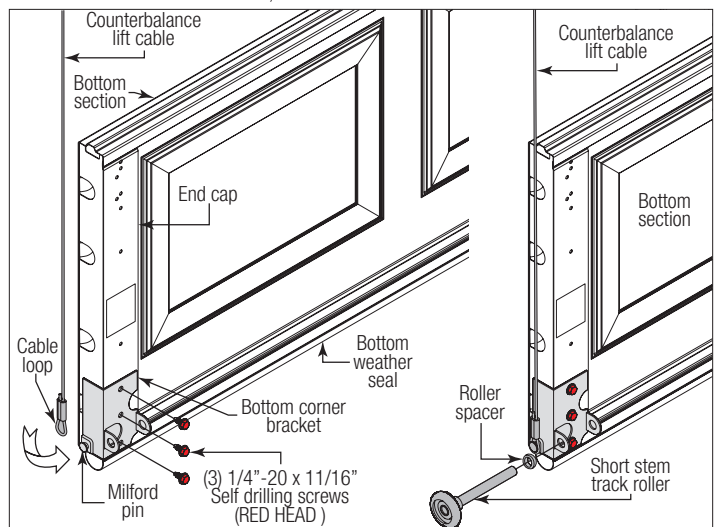

4 Attaching Top Fixtures To Top Section

NOTE: Reference Package Contents or Breakdown Of Parts, to determine which top fixtures you have.

IF YOU HAVE TOP FIXTURE ASSEMBLIES: Starting on the left hand side, align the upper center hole of top fixture base with the hole in the end stile of the top section and even with the edge of the top section. The slotted half of the top fixture base should be facing upwards. Fasten to section using (4) 1/4" - 20 x 11/16" self drilling screws. Insert short stem track roller into top fixture slide. Repeat same process for other right hand side.

IF YOU HAVE TOP FIXTURE BASES AND TOP FIXTURE SLIDES: Starting on the left hand side, align the top fixture base on top of the corner of the top section and even with the edge of the section. Fasten to section through end cap using (4) 1/4" - 20 x 11/16" self drilling screws. Loosely secure the top fixture slide to the top fixture base using (1) 5/16" - 18 x 3/4" carriage bolt and (1) 5/16" - 18 hex nut. Insert short stem track roller into top fixture slide. Repeat same process for other right hand side.

NOTE: The top fixture slide will be tightened and adjusted later, in step, Adjusting Top Fixture.

NOTE: Ensure the top fixture slides are able to slide along the top fixture bases. If needed, loosen the 1/4" - 20 flange hex nuts / 5/16" - 18 hex nuts.

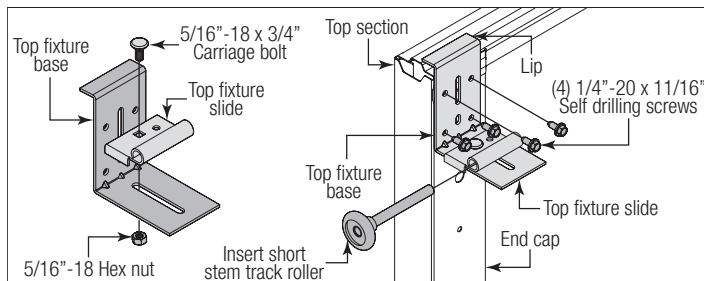
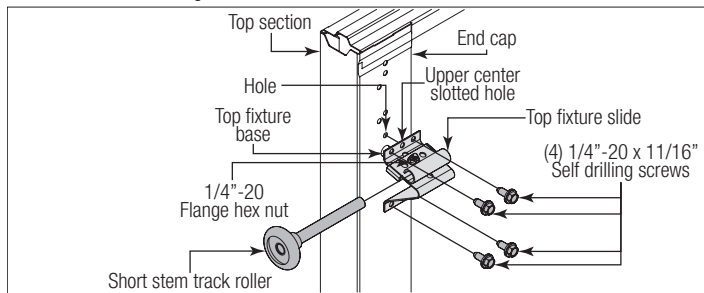

5 Attaching Hinges and Strut(s) To Sections

NOTE: Refer to door section identification, located in the pre-installation section of this manual.

NOTE: The graduated hinges can be identified by the number stamped on the lower hinge leaf.

NOTE: The #1 graduated end hinges serves as end hinges on the bottom section. The #1 graduated end hinges also serves as center hinges on all sections, except for the top section.

NOTE: The #2 graduated end hinges serves as end hinges on the Lock section.

NOTE: The #3 graduated end hinges serves as end hinges on the Intermediate I section.

NOTE: The #4 graduated end hinges serves as end hinges on the Intermediate II section.

NOTE: The #5 graduated end hinges serves as end hinges on the Intermediate III section.

NOTE: The #6 graduated end hinges serves as end hinges on the Intermediate IV section.

NOTE: The #7 graduated end hinges serves as end hinges on the Intermediate V section.

ATTACHING HINGES TO SECTIONS: Starting on the left hand side of the bottom section, align the lower hinge leaf of the #1 graduated end hinge over the holes, located at the top of the end caps. Attach lower leaf to the end caps with (2) 1/4" - 14 x 5/8" self tapping screws. Repeat for other side. Next, align the lower hinge leaf of the #1 center hinges with the pre-punched holes at each center stile location(s), located at the top of the bottom section. Attach lower hinge leaf to the center stile with (2) 1/4" - 14 x 5/8" self tapping screws.

IMPORTANT: ONCE THE 1/4" - 14 X 5/8" SELF TAPPING SCREWS ARE SNUG AGAINST THE LOWER HINGE LEAVES, TIGHTEN AN ADDITIONAL 1/4 TO 1/2 TURN TO RECEIVE MAXIMUM DESIGN HOLDING POWER.

ATTACHING STRUT(S) TO SECTIONS: Using the strut schedule, determine the placement of the struts for your door width and door height.

INSTALLATION ON THE TOP SECTION: Locate and center the strut at the top of the top section surface. Secure strut to top section using (2) 1/4" - 20 x 7/8" self drilling screws at each end and at each center stile locations.

INSTALLATION ON ALL OTHER SECTIONS: Locate and center the strut onto the section

surface and up against the bottom of the hinges. Center the strut side to side. Secure strut to the section using (2) 1/4" - 20 x 7/8" self drilling screws at each end and center stile locations.

NOTE: All struts are placed at the top of the sections and up against the bottom of the graduated hinges, for the intermediate, lock and bottom sections.

Strutting Schedule Key:		
TS = Top Section	I4 = Intermediate Section #4	LS = Lock Section
IW = Intermediate Section With Windows	I3 = Intermediate Section #3	BS = Bottom Section
I6 = Intermediate Section #6	I2 = Intermediate Section #2	ES = Every Section gets a strut.
I5 = Intermediate Section #5	I1 = Intermediate Section #1	RS = Remaining Sections gets a strut.

Strutting Schedule For Models 8000 and 8100					
Door Heights	Section Qty	Section Type	Door Widths		
			14'0" - 16'0"	17'0" - 18'0"	20'0"
6'0" - 7'0"	4	Solid	(1) TS	(3) TS, LS, BS	ES
		Windows	(1) TS	(1) 3" TS, (2) 2" LS, BS	ES
7'6" - 8'9"	5	Solid	(2) TS, BS	(3) TS, I1, BS	ES
		Windows	(1) 3" TS, (1) 2" BS	(1) 3" TS, (2) 2" I1, BS	ES
9'0" - 10'6"	6	Solid	(5) TS, I3, I2, I1, BS	ES	N/A
		Windows	(1) 3" TS, (4) 2" I3, I2, I1, BS	(1) 3" TS, (5) 2" RS	N/A
10'9" - 12'3"	7	Solid	(6) TS, I4, I3, I2, I1, BS	N/A	
		Windows	(1) 3" TS, (5) 2" I4, I3, I2, I1, BS	N/A	
12'6" - 14'0"	8	Solid	(7) TS, I5, I4, I3, I2, I1, BS	N/A	
		Windows	(1) 3" TS, (6) 2" I5, I4, I3, I2, I1, BS	N/A	

Strutting Schedule For Model 8200					
Door Heights	Section Qty	Section Type	Door Widths		
			14'0" - 16'0"	17'0" - 18'0"	20'0"
6'0" - 7'0"	4	Solid	(2) TS, BS	(3) TS, LS, BS	ES
		Windows	(1) 3" TS, (1) 2" BS	(1) 3" TS, (2) 2" LS, BS	ES
7'6" - 8'0"	5	Solid	(2) TS, BS	(3) TS, I1, BS	ES
		Windows	(1) 3" TS, (1) 2" BS	(1) 3" TS, (2) 2" I1, BS	ES
8'3" - 8'9"	5	Solid	(2) TS, BS	(3) 2" TS, I1, BS	N/A
		Windows	(1) 3" TS, (1) 2" BS	(1) 3" TS, (2) 2" I1, BS	N/A
9'0" - 10'6"	6	Solid	(5) TS, I3, I2, I1, BS	ES	N/A
		Windows	(1) 3" TS, (4) 2" I3, I2, I1, BS	(1) 3" TS, (5) 2" RS	N/A
10'9" - 12'3"	7	Solid	(6) TS, I4, I3, I2, I1, BS	N/A	
		Windows	(1) 3" TS, (5) 2" I4, I3, I2, I1, BS	N/A	
12'6" - 14'0"	8	Solid	(7) TS, I5, I4, I3, I2, I1, BS	N/A	
		Windows	(1) 3" TS, (6) 2" I5, I4, I3, I2, I1, BS	N/A	

NOTE: Depending on your door some sections may or may not require a strut to be installed onto the section.

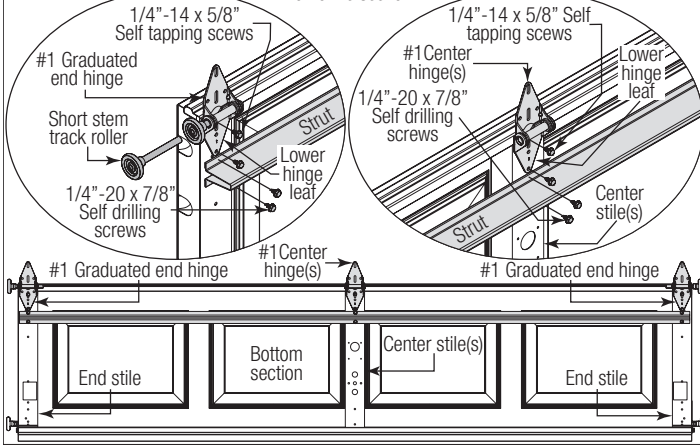

NOTE: Depending on your door some sections may or may not require a strut to be installed onto the section.

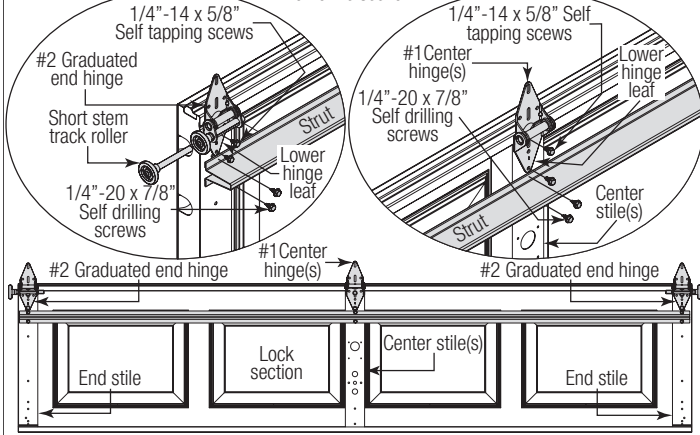

NOTE: Depending on your door some sections may or may not require a strut to be installed onto the section.

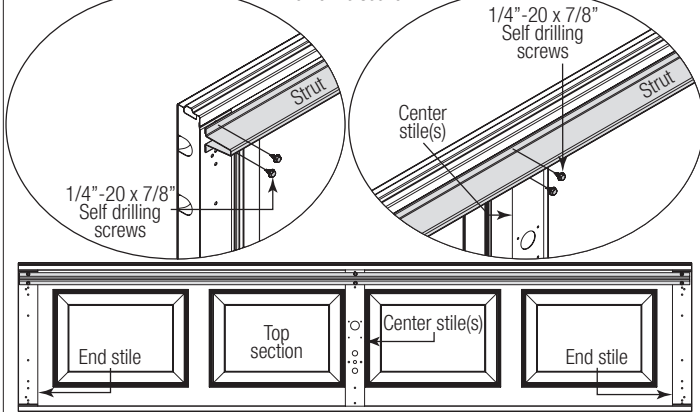

6 Step Plate

NOTE: Depending on your door, you may have two different kinds of Step Plates or two of the same kind of Step Plates. Refer to Package Contents, to determine which Step Plates you have.

IF YOU HAVE TWO OF THE SAME KINDS OF STEP PLATES: Locate the center most center stile of the bottom section of the door. On the inside of the door, center the step plate on the center most stile no higher than 6" from the bottom of the door. Using the step plate holes as a template, drill a 5/16" dia. hole along each side of the center stile, through the face of the door. Drill through insulation and door's face on an insulated door.

IMPORTANT: BE EXTREMELY CAREFUL TO KEEP DRILL STRAIGHT.

Mount the inside step plate and the outside step plate back to back, straddling the center stile. Secure with (2) 1/4" - 20 x 2-3/4" carriage bolts and 1/4" - 20 hex nuts.

IMPORTANT: DO NOT MOUNT THE STEP PLATE HIGHER THAN 6" FROM THE BOTTOM OF THE SECTION.

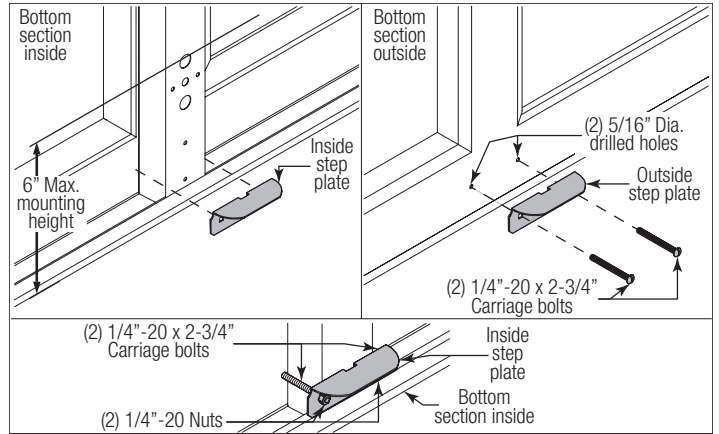

IF YOU HAVE TWO DIFFERENT KINDS OF STEP PLATES: Locate the center most center stile on the bottom section of the door. On the inside of the door and using the pre-punched holes at the bottom of the center stile as a template, drill (2) 7/32" dia. holes through the section. Using the previously drilled holes as a guide, enlarge the holes from outside the door to 7/16" dia. and assemble the outside and inside step plates to the section using (2) #8 x 1-5/8" screws.

CAUTION

DO NOT DRILL THROUGH OR ENLARGE HOLES ON THE INSIDE OF THE DOOR SECTION.

NOTE: After completing this step, continue with Step Lift Handles.

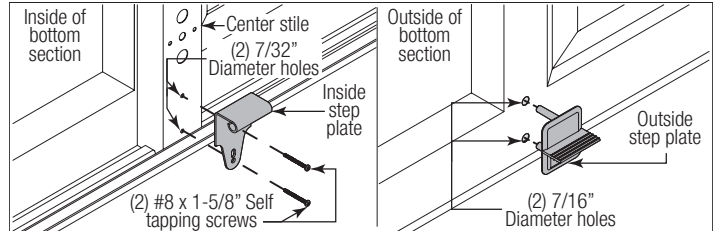

7 Lift Handle

NOTE: Doors with a Keyed lock do not require this lift handle.

Locate the inside center stile or the desired lift handle location on the lock (2nd) section of the door. Position the lower hole in the lift handle 4" from the bottom of the lock (2nd) section.

IMPORTANT: THE DISTANCE BETWEEN THE STEP PLATE AND THE MIDDLE OF THE LIFT HANDLE MUST BE 20" MINIMUM TO 30" MAXIMUM. IF NECESSARY REPOSITION THE UPPER LIFT HANDLE TO STAY WITHIN THE REQUIRED DIMENSION.

Using the lift handle holes as a template, drill (2) 9/32" dia. holes through the lock section. Enlarge the holes from the outside the door to 1/2" dia.

CAUTION

DO NOT DRILL THROUGH OR ENLARGE HOLES ON THE INSIDE OF THE DOOR SECTION.

Assemble the outside and inside lift handles to the lock section using (2) spacers, (2) 1/4" - 20 x 2-1/2" carriage bolts and (2) 1/4" - 20 hex nuts.

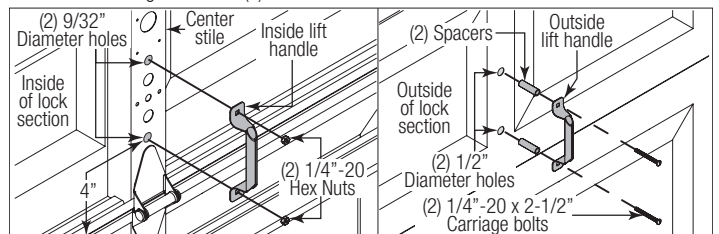

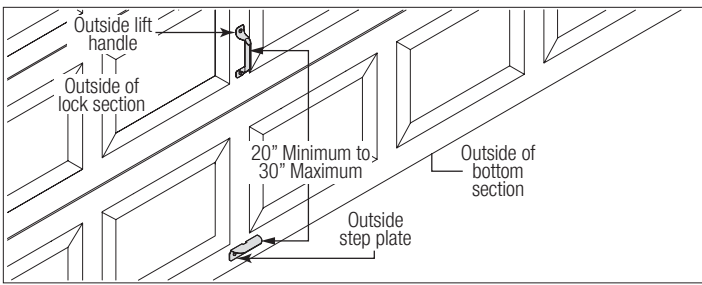

8 Positioning Bottom Section

Center the bottom section in the door opening. Level the section using wooden shims (if necessary) under the bottom section. When the bottom section is leveled, temporarily hold it in place by driving a nail into the jamb and bending it over the edge of the bottom section on both sides.

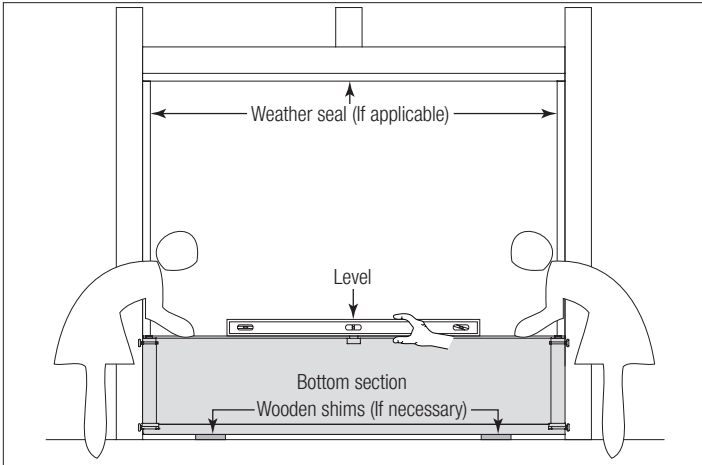

9 Attaching Vertical Tracks To Jamb

NOTE: Depending on your door, you may have Fully Adjustable Flag Angles or you may have Angle Mount Vertical Track Assemblies. Refer to Package Contents / Breakdown of Parts, to determine which Flag Angles / Vertical Track Assemblies you have.

IMPORTANT: IF YOUR DOOR IS TO BE INSTALLED PRIOR TO A FINISHING CONSTRUCTION OF THE BUILDING'S FLOOR, THE VERTICAL TRACKS AND THE DOOR BOTTOM SECTION ASSEMBLY SHOULD BE INSTALLED SUCH THAT WHEN THE FLOOR IS CONSTRUCTED, NO DOOR OR TRACK PARTS ARE TRAPPED IN THE FLOOR CONSTRUCTION.

IMPORTANT: THE TOPS OF THE VERTICAL TRACKS MUST BE LEVEL FROM SIDE TO SIDE. IF THE BOTTOM SECTION WAS SHIMMED TO LEVEL IT, THE VERTICAL TRACK ON THE SHIMMED SIDE MUST BE RAISED THE HEIGHT OF THE SHIM.

NOTE: Make sure the counterbalance lift cable is located between the track rollers and the door jamb.

Starting on the left hand side of the bottom section, remove the nail. Position the left hand vertical track assembly over the track rollers of the bottom section and install, as shown. Drill 3/16" pilot holes into the door jamb for the lag screws.

FOR FULLY ADJUSTABLE FLAG ANGLES: Loosely fasten jamb brackets and flag angle to the jamb using 5/16" x 2" lag screws. Tighten lag screws, securing the bottom jamb bracket to jamb, maintain 3/8" to 5/8" spacing, between the bottom section and vertical track. Hang counterbalance lift cable over flag angle. Repeat same process for other side.

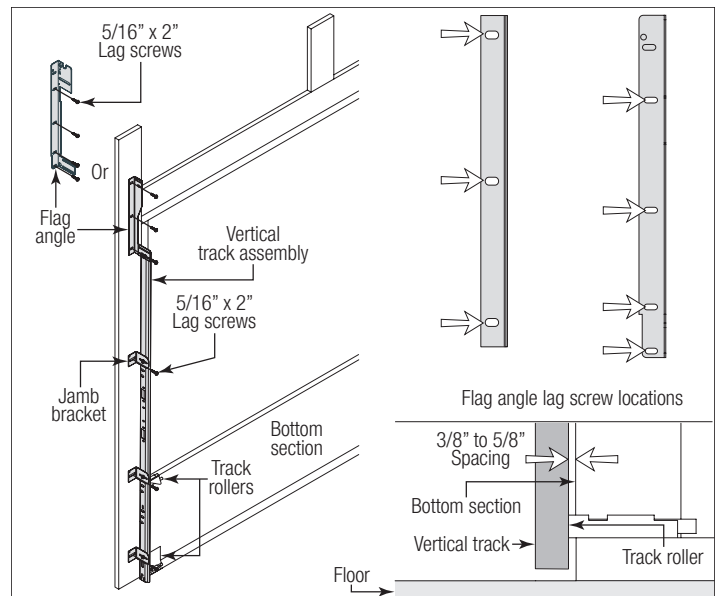

FOR ANGLE MOUNT VERTICAL TRACK ASSEMBLY: Loosely fasten the slots in the wall angle to the jamb using 5/16" x 2" lag screws. Tighten lag screws, securing the bottom slot in the wall angle, maintain 3/8" to 5/8" spacing as shown between the bottom section and vertical track. Hang counterbalance lift cable over angle mount. Repeat same process for other side.

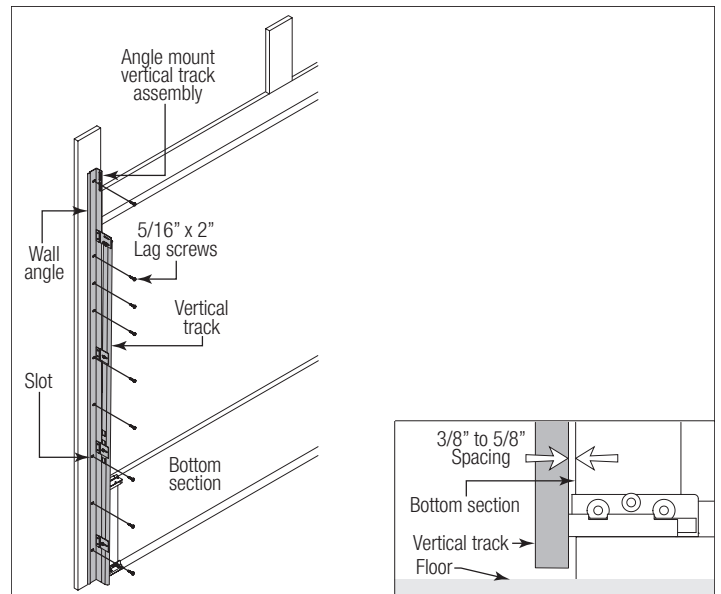

10 Stacking Sections

NOTE: The sections can be identified by the graduation of the installed graduated end hinges. The smallest graduated end hinge on the section should be stacked on top of the bottom section, with each graduated end hinge increasing as the sections are stacked, see door section identification or Breakdown Of Parts.

NOTE: Make sure graduated end and center hinges are flipped down, when stacking another section on top.

NOTE: Larger doors will use long stem track rollers with double graduated end hinges.

Place track rollers into graduated end hinges of remaining sections. With assistance, lift second section and guide the track rollers into the vertical tracks. Lower section until it is seated against bottom section. Flip hinges up. Fasten center hinge(s) first; then end hinges last using 1/4" - 14 x 5/8" self tapping screws.

NOTE: Larger doors with double graduated end hinges, fasten both hinges to connect the sections using 1/4" - 14 x 5/8" self tapping screws.

Repeat same process for other sections, except top section.

IMPORTANT: PUSH & HOLD THE HINGE LEAFS SECURELY AGAINST THE SECTIONS WHILE SECURING WITH FASTENERS TO IT. THERE SHOULD BE NO GAP BETWEEN THE HINGE LEAVES AND THE SECTIONS.

NOTE: Install lock at this time (sold separately). See optional installation step, Side Lock.

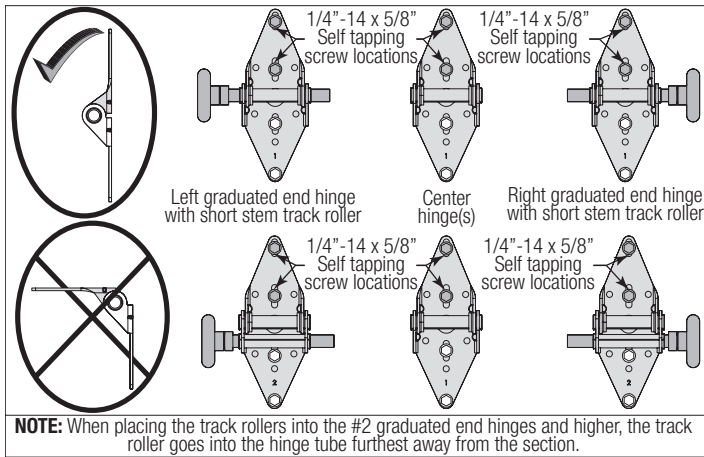
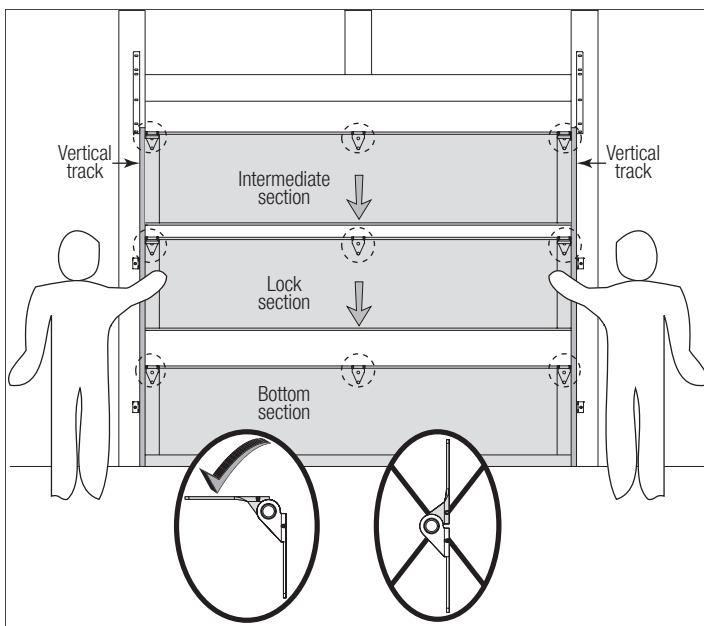

11 Stacking Top Section

Place the top section in the opening. Install a nail to prevent the top section from falling backwards. Now, flip up the hinge leaves, hold tight against section, and fasten center hinges first and end hinges last (refer to step, Stacking Sections). Vertical track alignment is critical. Position flag angle or wall angle between 1-11/16" (43 mm) to 1-3/4" (44 mm) from the edge of the door; tighten the bottom lag screw. Flag angles must be parallel to the door sections. Repeat for other side.

IMPORTANT: THE DIMENSION BETWEEN THE FLAG ANGLES OR WALL ANGLES MUST BE DOOR WIDTH PLUS 3-3/8" (86MM) TO 3-1/2" (89 MM) FOR SMOOTH, SAFE DOOR OPERATION.

FOR FULLY ADJUSTABLE TRACK: Complete the vertical track installation by securing the jamb bracket(s) and tightening the other lag screws. Push the vertical track against the track rollers so that the track rollers are touching the deepest part of the curved side of the track; tighten all the track bolts and nuts. Repeat for other side.

FOR ANGLE MOUNT TRACK: Complete the vertical track installation by securing the jamb bracket(s) and/or tightening the other lag screws. Push the vertical track against the track rollers so that the track rollers are touching the deepest part of the curved side of the vertical track, as shown. Repeat for other side.

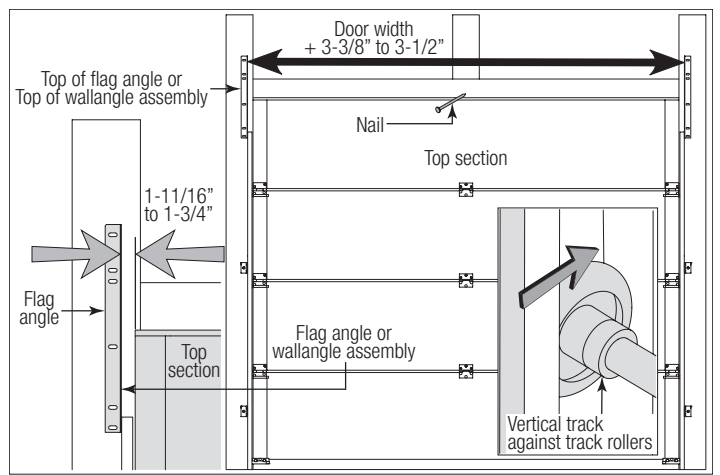

12 Attaching Horizontal Tracks

NOTE: Depending on your door, you may have Fully Adjustable Flag Angles or you may have Angle Mount Vertical Track Assemblies. Refer to Package Contents / Breakdown of Parts, to determine which Flag Angles / Vertical Track Assemblies you have.

⚠ WARNING

DO NOT RAISE DOOR UNTIL HORIZONTAL TRACKS ARE SECURED AT REAR, AS OUTLINED IN STEP, REAR BACK HANGS, OR DOOR COULD FALL FROM OVERHEAD POSITION CAUSING SEVERE OR FATAL INJURY.

IF YOU HAVE FLAG ANGLES: To install horizontal track, place the curved end over the top track roller of the top section. Align the bottom of the horizontal track with the top of the vertical track. Tighten the horizontal track to the flag angle with (2) 1/4" - 20 x 5/8" carriage bolts and (2) 1/4" - 20 flange hex nuts.

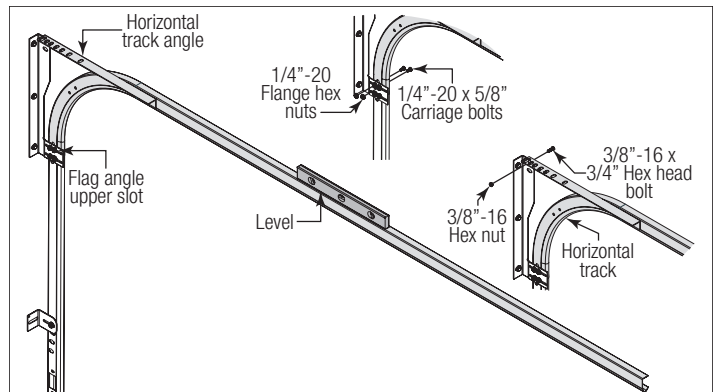

IF YOU HAVE ANGLE MOUNT: To install horizontal track, place the curved end over the top track roller of the top section. Align the bottom of the horizontal track with the top of the vertical track. Tighten the horizontal track to the angle mount with (2) 1/4" - 20 x 5/8" carriage bolts and (2) 1/4" - 20 flange hex nuts.

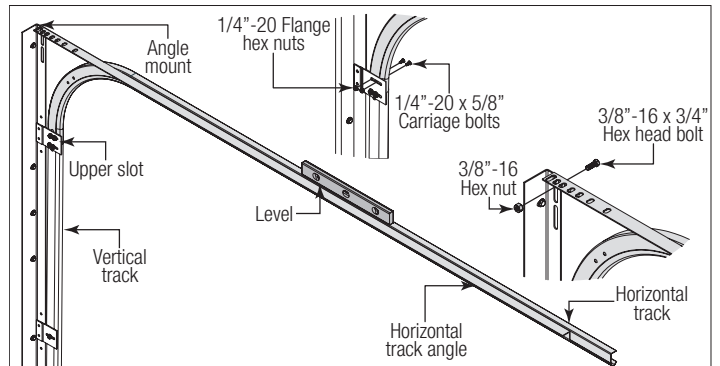

Next level the horizontal track assembly and bolt the horizontal track angle to the first encountered slot in the flag angle / angle mount using (1) 3/8" - 16 x 3/4" hex head bolt and (1) 3/8" - 16 hex nut. Repeat for other side. Remove nail that was temporarily holding the top section in position.

IMPORTANT: FAILURE TO REMOVE NAIL BEFORE ATTEMPTING TO RAISE DOOR COULD CAUSE PERMANENT DAMAGE TO TOP SECTION.

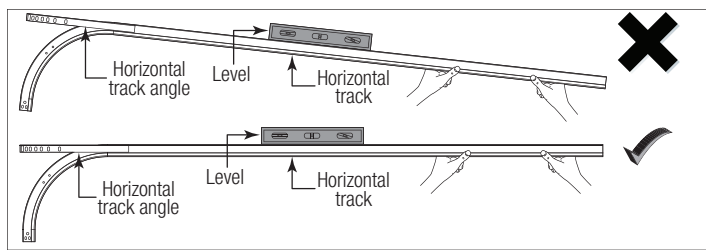

13 Adjusting Top Fixtures

NOTE: Refer to Package Contents / Breakdown Of Parts, to determine which Top Fixtures you have.

With horizontal tracks installed, you can now adjust the top fixtures. Vertically align the top section of the door with the lower sections. Once aligned, position the top fixture slide, out against the horizontal track. Maintaining the slide's position, tighten the 1/4" - 20 flange hex nut or the 5/16" - 18 hex nut to secure the top fixture slide to the top fixture base. Repeat for other side.

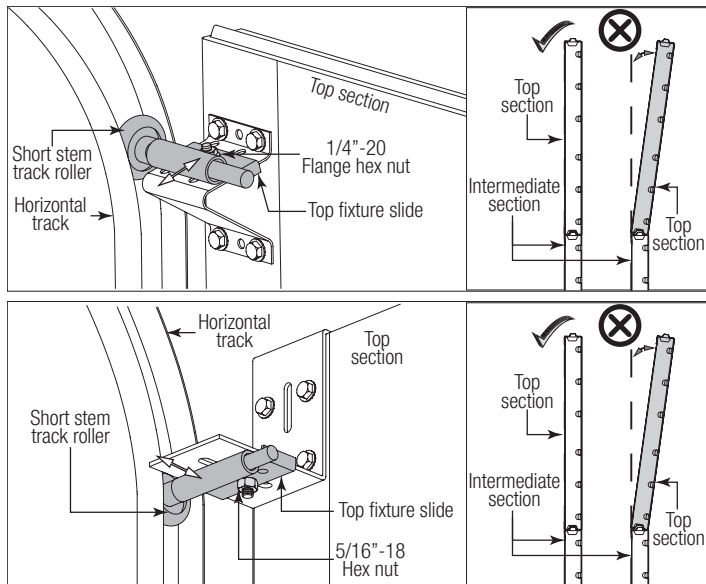

COUNTERBALANCE INSTALLATION INSTRUCTIONS

13 Attaching Head Plates

NOTE: Refer to Package Contents / Breakdown of Parts, to determine which head plates you have.

NOTE: Prior to fastening head plates into the door jamb, pilot drill using a 3/16" drill bit.

IMPORTANT: RIGHT AND LEFT HAND IS ALWAYS DETERMINED FROM INSIDE THE BUILDING LOOKING OUT.

NOTE: Head plates are right and left hand.

Attach the left hand head plate to the left hand horizontal track angle using (2) 3/8" - 16 x 3/4" hex head bolts and (2) 3/8" - 16 nuts. Secure the top of the head plate to the jamb using 5/16" x 2" lag screw(s). Repeat the same process for right hand side.

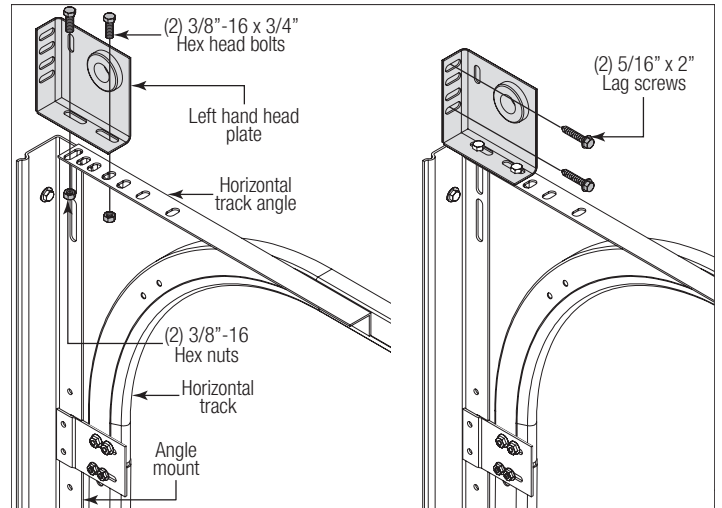
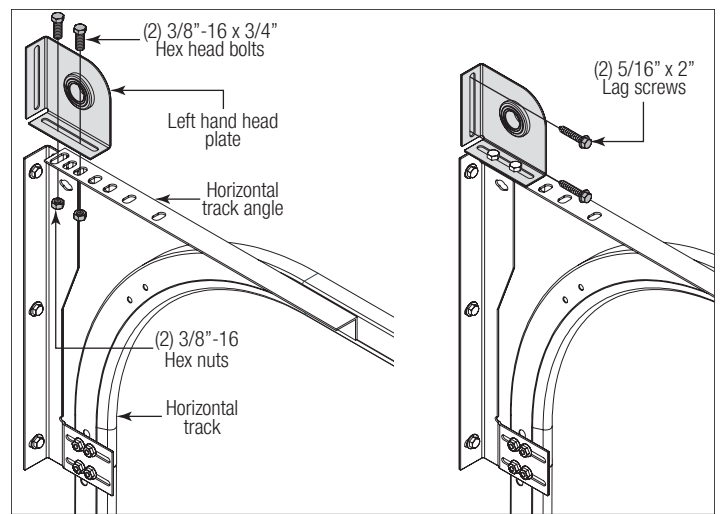

14 Attaching Spring Anchor Bracket to Wall

NOTE: Refer to Package Contents / Breakdown of Parts, to determine which Spring Anchor Bracket(s) came with your door.

NOTE: Drill 3/16" pilot holes into header for the lag screws.

NOTE: Refer to Package Contents / Breakdown of Parts, to determine if your door came with a coupler assembly. If your door came with a coupler assembly, the mounting surface needs to be a minimum of 17" wide. The two spring anchor brackets will need to be spaced 12" to 14" apart at the center of the door, as shown.

NOTE: If your door came with (4) springs, each of the outer springs mounting surface will need to be a minimum of 3" wide.

NOTE: If needed, measure the diameter of your springs. If you have a one piece shaft with 3-3/4" diameter springs, they do not share spring anchor brackets and do not have a coupler assembly.

First, locate the center of the door. Mark a vertical pencil line on the mounting surface above the door, at the center. Measure from the center of the bearing, in one of the head plates, downwards, to the top of the door. Using that measurement, measure that distance upwards from the top of the door to the mounting surface and mark a horizontal pencil line which intersects the vertical pencil line.

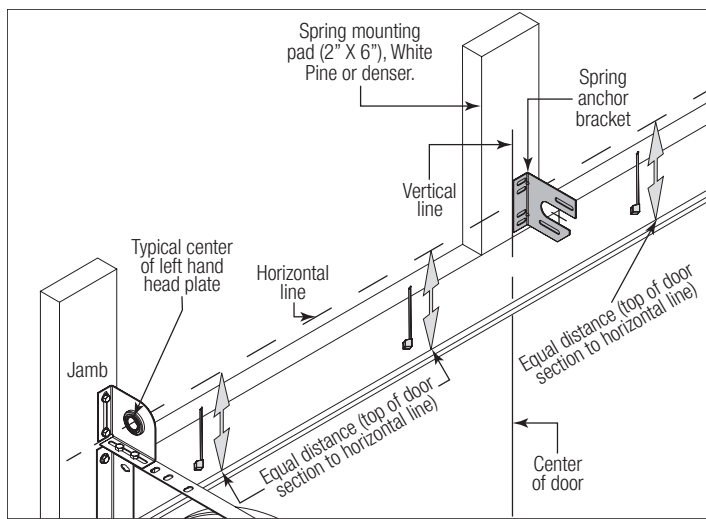

IF YOUR DOOR DID NOT COME WITH A CENTER COUPLER ASSEMBLY OR TORSION SPRINGS LESS THAN 3-3/4" ID: Mark a vertical pencil line on the mounting surface above the door, at the center. Align the edge of the spring anchor bracket with the vertical pencil line and the center of the spring anchor bracket with the horizontal pencil line; this is to ensure the torsion shaft is level between the spring anchor bracket and head plates.

NOTE: On some single spring doors, the spring can be longer than half the opening width. If your spring is longer, then the spring anchor bracket must be mounted off center for the spring to fit properly. Measure spring length adding room for spring growth during winding, to determine appropriate spring anchor bracket location.

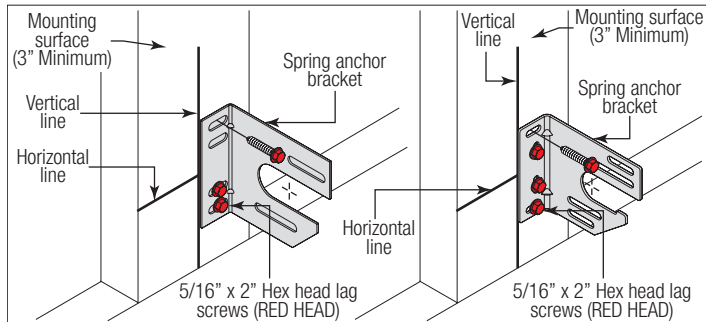

IF YOUR DOOR DID COME WITH A CENTER COUPLER ASSEMBLY OR 3-3/4" ID TORSION SPRINGS: Mark a vertical pencil line on the mounting surface above the door, at the center. Split the difference up and position the (2) spring anchor brackets apart from each other. Mark two vertical pencil lines, one for each spring anchor bracket onto the mounting surface above the door.

NOTE: If your door came with a center coupler assembly or if it utilizes 3-3/4" springs, the springs will not share a spring anchor bracket.

NOTE: If your door has (4) springs, split the distance between the center of the door and the head plate on each side to locate the intermediate spring anchor brackets.

Attach each of the spring anchor bracket(s) to the mounting surface, using 5/16" x 2" RED HEAD lag screws, as shown.

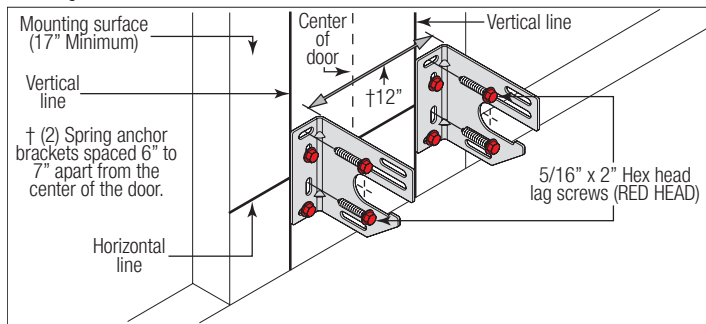

15 Torsion Spring Assembly

NOTE: Refer to the Package Contents and/or Breakdown of Parts to determine if your door came with a coupler assembly.

IMPORTANT: RIGHT AND LEFT HAND IS ALWAYS DETERMINED FROM INSIDE THE BUILDING LOOKING OUT.

IMPORTANT: IDENTIFY THE TORSION SPRINGS PROVIDED AS EITHER RIGHT WOUND (RED WINDING CONE), WHICH GOES ON THE LEFT HAND SIDE OR LEFT WOUND (BLACK WINDING

CONE), WHICH GOES ON THE RIGHT HAND SIDE.

IMPORTANT: ON SINGLE SPRING APPLICATIONS, ONLY A LEFT WOUND (BLACK WINDING CONE), IS REQUIRED.

NOTE: The set screws used on all winding cones and cable drums are colored red. DO NOT identify right and left hand by the set screw color.

IF YOU DON'T HAVE A COUPLER ASSEMBLY: Facing the inside of the door, lay the torsion shaft / torsion keyed shaft on the floor. Lay the torsion spring with the black winding cone and the black cable drum at the right end of the torsion shaft / torsion keyed shaft. Lay the torsion spring with the red winding cone and the red cable drum at the left end of the torsion shaft / torsion keyed shaft. Slide the spring anchor bearing onto the torsion shaft / torsion keyed shaft followed by the torsion springs and cable drums.

IMPORTANT: THE SPRING ANCHOR BEARING, TORSION SPRINGS, AND CABLE DRUMS MUST BE POSITIONED, AS SHOWN.

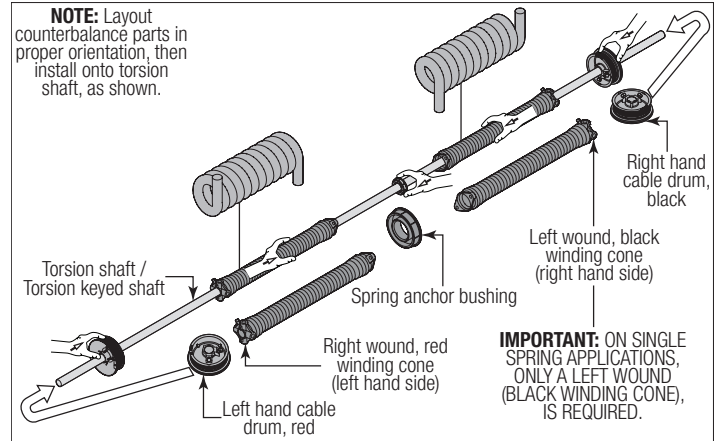

With assistance, pick up the torsion spring assembly and slide one end of the torsion shaft / torsion keyed shaft through one head plate. Lay the middle of the torsion shaft / torsion keyed shaft into the spring anchor bracket. Slide the other end of the torsion shaft / torsion keyed shaft into the other head plate.

NOTE: Position the torsion shaft so that equal amounts of the shaft extend from each head plates.

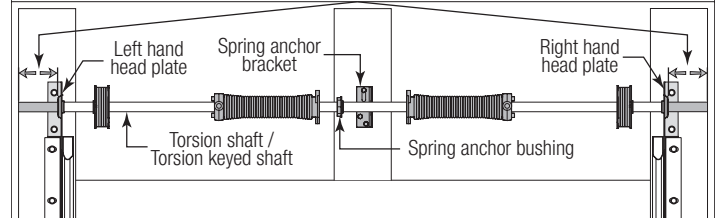

IF YOU HAVE A COUPLER ASSEMBLY: Disassemble the coupler assembly by removing the (3) 3/8" - 16 x 1-1/2" hex head screws, (6) 3/8" washers, (3) 3/8" lock washers and the (3) 3/8" - 16 hex nuts from the coupler halves. Loosen the set screws. Set the components aside.

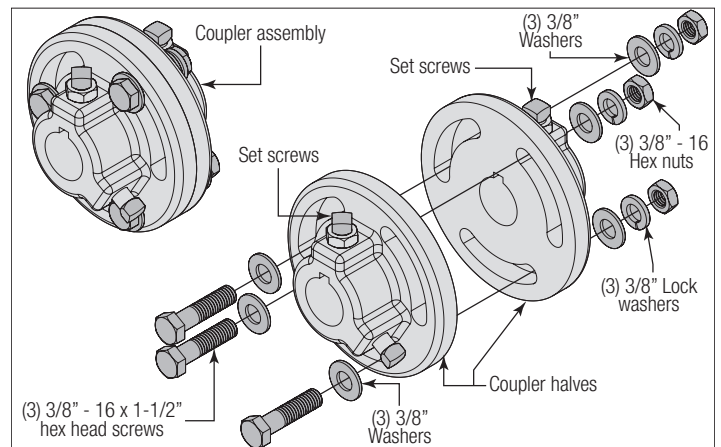

Facing the inside of the door, lay the (2) torsion keyed shafts on the floor. One torsion keyed shaft on the left hand side and the other torsion keyed shaft on the right hand side. Starting on the left hand side, lay one of the coupler halves, the spring anchor bearing, torsion spring with the red winding cone and the red cable drum at the left end of the torsion keyed shaft. Next on the right hand side, lay the other coupler half, spring anchor bearing, the torsion spring with the black winding cone, and the black cable drum at the right end of the torsion keyed shaft. Slide the coupler halves, spring anchor bearings onto the torsion keyed shafts followed by the torsion springs and the cable drums, as shown.

IMPORTANT: THE COUPLER HALVES, SPRING ANCHOR BEARINGS, TORSION SPRINGS, CABLE DRUMS MUST BE POSITIONED, AS SHOWN.

Slide the flat edge of the coupler half flush with the side edge of the torsion keyed shaft. Insert (1) key into the slot of both the coupler half and the slot in the torsion keyed shaft. Tighten the (2) set screws and the locking nut to secure the coupler half to the torsion keyed shaft, as shown.

NOTE: Tighten the set screws to 14-15 ft-lbs (Once set screws contact the shaft, tighten screws an additional 1/2 turn).

Repeat the same process for the other coupler half.

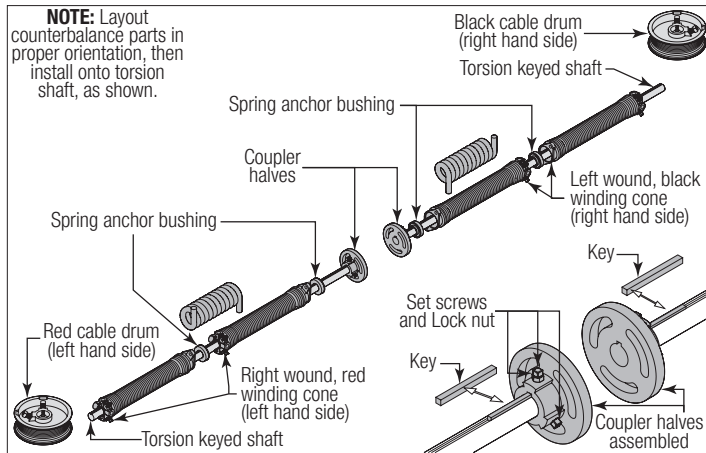
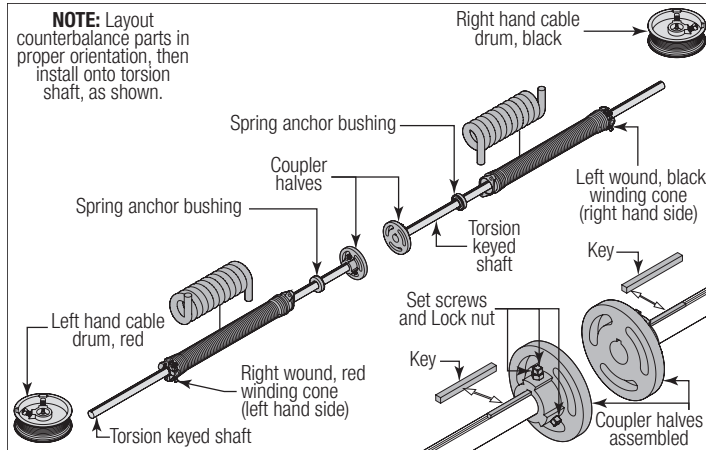

With assistance and starting on the left hand side of door, pick up the left hand torsion spring assembly and slide one end of the torsion keyed shaft through the head plate. Lay the other side of the torsion keyed shaft into the spring anchor bearing. Repeat the same process for the right hand torsion spring assembly.

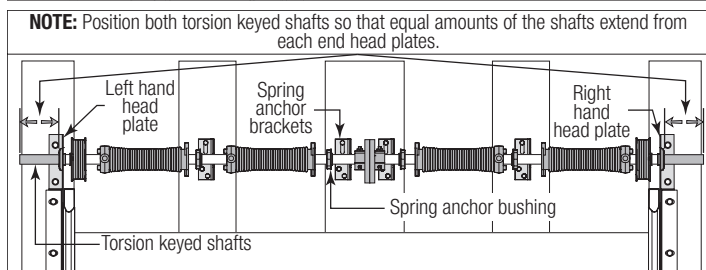
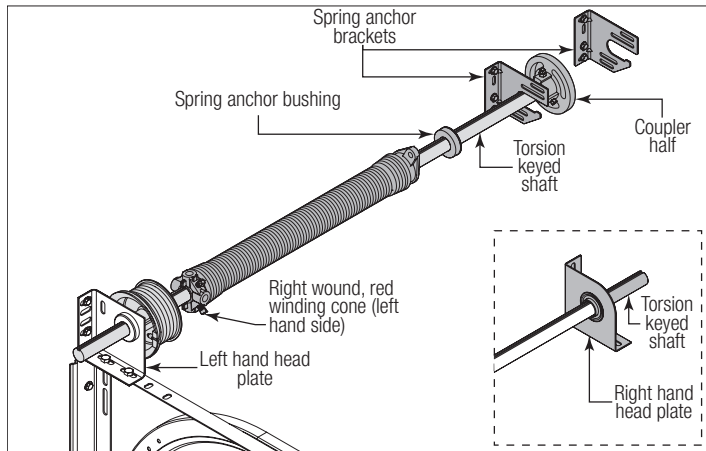

16

Attaching Springs to Spring Anchor Bracket

NOTE: Refer to Package Contents / Breakdown of Parts, to determine which Spring Anchor Bracket(s) came with your door.

NOTE: Refer to Package Contents / Breakdown of Parts, to determine if your door came with a coupler assembly.

IMPORTANT: THE SPRING WARNING TAG(S) SUPPLIED MUST BE SECURELY ATTACHED TO THE STATIONARY SPRING CONE(S) IN PLAIN VIEW. SHOULD A REPLACEMENT SPRING WARNING TAG BE REQUIRED, CONTACT WAYNE DALTON FOR FREE REPLACEMENTS.

NOTE: Measure the diameter of your springs. If your spring diameter is 3-3/4", the springs do not share spring anchor brackets. If your spring diameter is either 2" or 2-5/8", then two springs will share the same spring anchor bracket, unless a coupler assembly is provided.

IF YOU DON'T HAVE A COUPLER ASSEMBLY: Slide spring anchor bearing into the spring. Align the stationary spring cone(s) with the holes in the spring anchor bracket. Secure the torsion spring(s) to the spring anchor bracket with (2) 3/8" - 16 x 1-1/2" hex head bolts and (2) 3/8" - 16 nuts.

IMPORTANT: NEVER USE MORE THAN ONE BEARING WHEN ATTACHING TWO SPRINGS TO ONE SPRING ANCHOR BRACKET.

IF YOU HAVE A COUPLER ASSEMBLY: Slide spring anchor bracket bearing into the spring. Align the stationary spring cone with the holes in the spring anchor bracket. Secure the torsion spring to the spring anchor bracket with (2) 3/8" - 16 x 1-1/2" hex head bolts and (2) 3/8" - 16 nuts. Repeat the same process for the other spring anchor bracket.

At the middle of the two spring anchor brackets, re-assemble the coupler assembly by loosely fastening the coupler halves together using the (3) 3/8" - 16 x 1-1/2" hex head screws, (6) 3/8" washers, (3) 3/8" lock washers and the (3) 3/8" - 16 hex nuts, previously removed.

NOTE: Ensure both torsion keyed shafts have equal amounts of the shafts extending from each head plate.

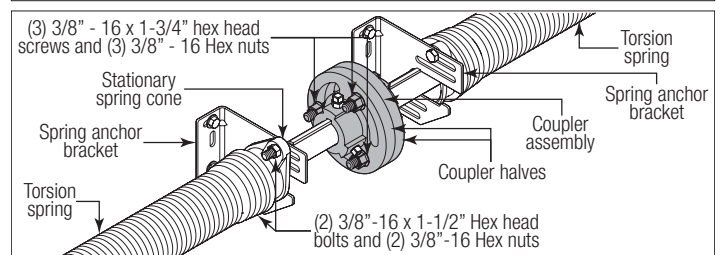
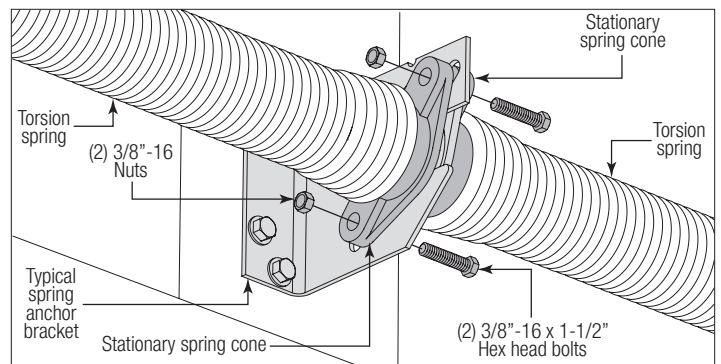
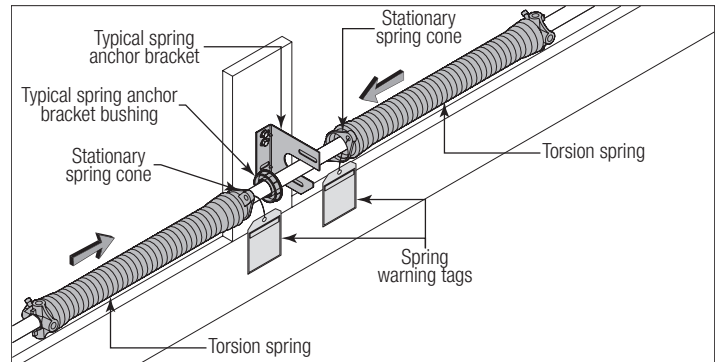

17

Attaching Counterbalance Lift Cables

Starting on the left hand side, thread the counterbalance lift cable up and around the front side of the left hand cable drum.

IMPORTANT: VERIFY THAT THERE ARE NO OBSTRUCTIONS IN THE TRAVEL PATH OF THE

DOOR SECTIONS OR COUNTERBALANCE LIFT CABLES.

NOTE: Always assemble the left hand cable and cable drum first to help maintain equal cable tension on both sides of the door.

Hook the counterbalance lift cable into the left hand cable drum. Slide the left hand cable drum up against the left hand end bearing bracket. Counterbalance lift cable should terminate at the 3 o'clock position.

NOTE: If you have torsion keyed shaft(s), insert (1) key into the slot of both the cable drum and the slot in the torsion keyed shaft, as shown.

Rotate the left hand drum and torsion shaft until counterbalance lift cable is taut. Now attach locking pliers to the torsion shaft and brace locking pliers up against jamb to keep counterbalance lift cable taut. Tighten the set screws in the drum to 14-15 ft-lbs of torque (once set screws contact the torsion shaft, tighten screws an additional 1/2 turn for solid shaft and one full turn for tubular shaft). Repeat for right hand side.

IMPORTANT: INSPECT EACH COUNTERBALANCE LIFT CABLE MAKING SURE IT IS SEATED PROPERLY ONTO THE CABLE DRUM AND THAT BOTH COUNTERBALANCE LIFT CABLES HAVE EQUAL TENSION.

CHECK COUNTERBALANCE LIFT CABLES FOR EQUAL TENSION:

1. Attach locking pliers to track above top roller.
2. Grasp cable at approximate mid-door height location.
3. Draw cable toward you about 1/2" to 1" and release, noting the response of the cable.
4. Repeat above steps for other cable.
5. Adjust cable tension as needed until right and left cables both respond the same.

Once the counterbalance cables are set and if applicable tighten the coupler assembly together by tightening the (3) 3/8" - 16 nylon hex nuts to secure the coupler halves together.

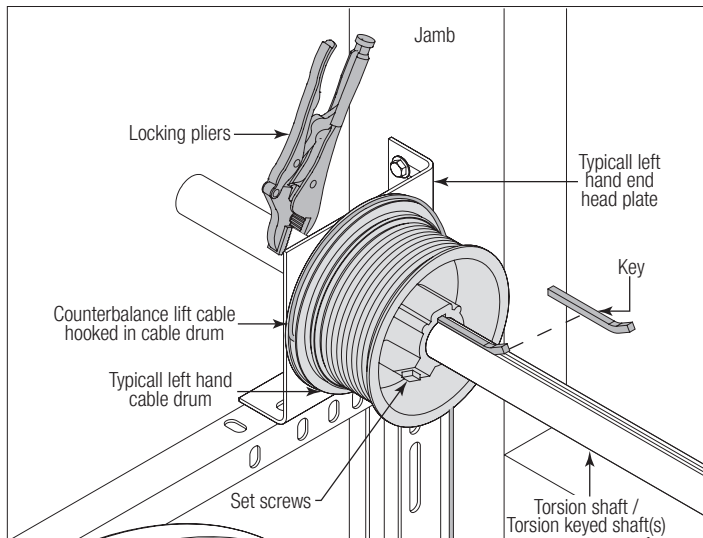
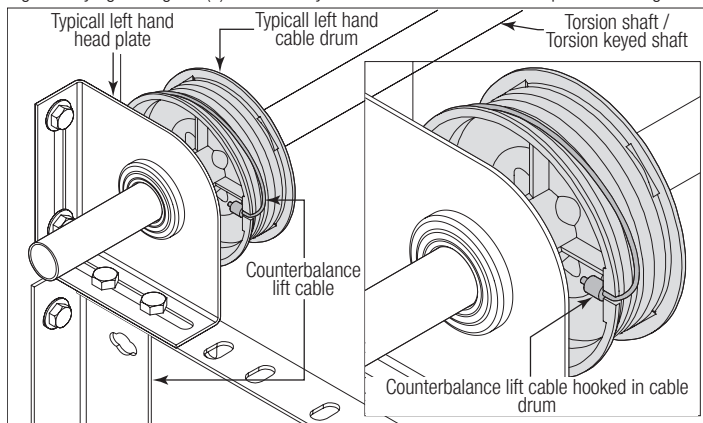

18 Chalking Torsion Spring(s)

NOTE: If your springs have stenciling, then skip this step.

Draw a chalk line horizontally along the center of the torsion spring coil(s). As the torsion spring is wound, the chalk line will create a spiral. This spiral can be used to count and determine the number of turns that are applied on the torsion spring.

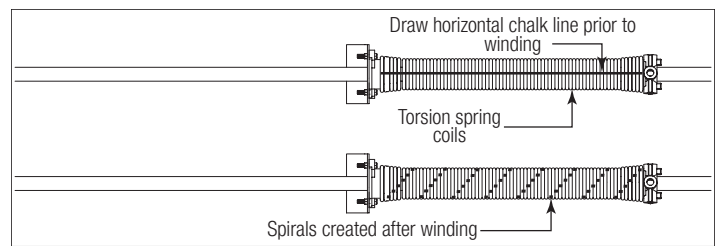

19 Securing Door for Spring Winding

With the door in the fully closed position, place locking pliers onto both vertical tracks just above the third track roller. This is to prevent the garage door from rising while winding springs.

NOTE: Check the following before attempting to wind torsion spring(s):

- a. Counterbalance lift cables are secured at bottom corner brackets.
- b. Counterbalance lift cables are routed unobstructed to cable drums.
- c. Counterbalance lift cables are correctly installed and wound onto cable lift drums.
- d. Counterbalance lift cables are taut and have equal tension on both sides.
- e. Cable lift drums are against head plates and set screws are tight.
- f. Torsion spring or springs are installed correctly.
- g. Review the label attached to the spring warning tag, to determine number of spring turns required.

NOTE: Door MUST be closed and locked when winding or making any adjustments to the torsion spring(s).

WARNING

FAILURE TO ENSURE DOOR IS IN A CLOSED POSITION AND TO PLACE LOCKING PLIERS ONTO VERTICAL TRACK CAN ALLOW DOOR TO RISE AND CAUSE SEVERE OR FATAL INJURY.

Winding Bars (Steel Rods)	Size Of Winding Bar (Inches)	Spring Inner Diameter Used On
—	1/2" dia. x 18"	2" and 2-5/8"
—	5/8" dia. x 24"	3-3/4"

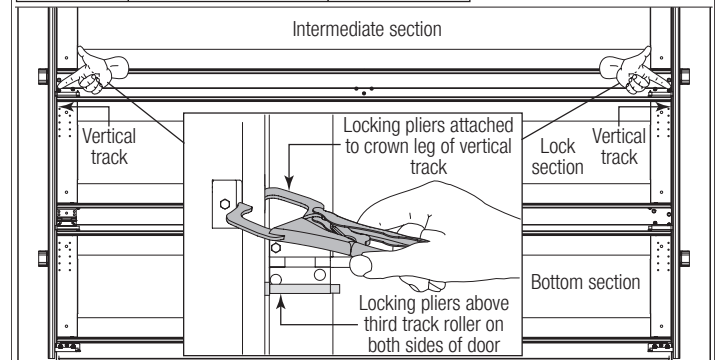

20 Winding Spring(s)

WARNING

WINDING SPRING IS AN EXTREMELY DANGEROUS PROCEDURE AND SHOULD BE PERFORMED ONLY BY A TRAINED DOOR SYSTEM TECHNICIAN USING PROPER TOOLS AND INSTRUCTIONS.

WARNING

USE ONLY SPECIFIED WINDING BARS, AS STATED IN STEP SECURING DOOR FOR SPRING WINDING. DO NOT SUBSTITUTE WITH SCREWDRIVERS, PIPE, ETC. OTHER TOOLS MAY FAIL OR RELEASE FROM THE SPRING CONE AND CAUSE SEVERE OR FATAL INJURY.

⚠️ WARNING

PRIOR TO WINDING THE SPRING, ENSURE YOU'RE WINDING IN THE PROPER DIRECTION AS SHOWN BELOW. OTHERWISE THE SPRING FITTING MAY RELEASE FROM SPRING AND RESULT IN SEVERE OR FATAL INJURY.

Position a ladder slightly to the side of the spring so that the winding cone is easily accessible, and so your body is not directly in line with the winding bars.

Check the label attached to the spring warning tag for the required number of complete turns to balance your door.

HOW TO WIND TORSION SPRINGS:

1. Insert one winding rod snugly into winding cone, to full socket depth
2. Maintaining a tight grip on the winding rod rotate it slowly in the proper direction, as shown below.
3. If there is any slippage of the winding rod in the winding cone socket, reverse the direction of winding and return the cone to its original position. Remove the winding rod from the winding cone socket. Reseat the winding rod in the socket. Start over at Step #1.
4. When the winding rod is vertical above the winding cone, insert another winding rod into one of the other sockets, being careful to seat it snugly and at full socket depth.
5. Hold the spring with the second winding bar, and remove the first.
6. Repeat Steps #2 through #5 until the complete turns have been applied.

IMPORTANT: AFTER WINDING THE SPRING(S), TIGHTEN THE SET SCREWS IN THE WINDING CONE TO 14-15 FT-LBS OF TORQUE (ONCE SET SCREWS CONTACT THE TORSION SHAFT, TIGHTEN SCREWS AN ADDITIONAL 1/2 TURN FOR SOLID SHAFT AND ONE FULL TURN FOR TUBULAR SHAFT).

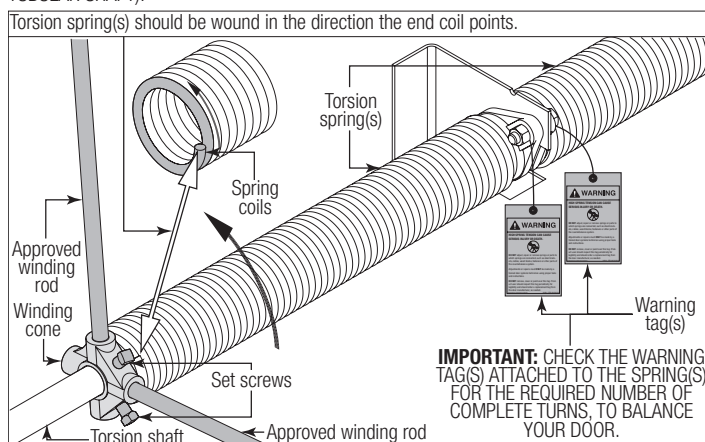

21

Attaching Rear Back Hangs

IMPORTANT: HOLD THE DOOR DOWN TO PREVENT IT FROM RISING UNEXPECTEDLY IN THE EVENT THE SPRING(S) WERE OVER-WOUND AND CAUTIOUSLY REMOVE LOCKING PLIERS FROM VERTICAL TRACKS.

Raise the door until the top section and half of the next section are in the horizontal track radius. Do not raise door any further since rear of horizontal tracks are not yet supported.

⚠️ WARNING

RAISING DOOR INTO THE LOOSE HORIZONTAL TRACKS CAN RESULT IN DOOR FALLING AND CAUSE SEVERE OR FATAL INJURY.

Clamp a pair of locking pliers onto the vertical tracks just above the second track roller on one side, and just below the second track roller on the other side. This will prevent the door from raising or lowering while installing the rear back hangs.

Using the chart below, select the appropriate perforated angle (may not be supplied). Fabricate and install rear back hangs, as shown.

Perforated Angle Gauge Weight Limitations:

Perforated Angle Gauge	Door Balance Weight
2" x 2" x 12 Gauge	800 lbs. to 1600 lbs.
1-1/4" x 1-1/4" x 13 Gauge	305 lbs. to 610 lbs.
1-1/4" x 1-1/4" x 15 Gauge	220 lbs. to 440 lbs.
1-1/4" x 1-1/4" x 16 Gauge	175 lbs. to 350 lbs.

NOTE: If an opener is installed, position horizontal tracks one hole above level when securing it to the rear back hangs.

⚠️ WARNING

MAKE SURE BACK HANGS ARE BRACED SUFFICIENTLY TO RESIST ANY MOTION DURING SPRING APPLICATION AND DOOR TRAVEL. IF BACK HANGS PIVOT OR DEFLECT, ADD REINFORCEMENT UNTIL THEY REMAIN FIRM AND STATIONARY. ANY BACK HANG THAT IS BENT MUST BE REPLACED.

⚠️ WARNING

KEEP HORIZONTAL TRACKS PARALLEL AND WITHIN 3/4" TO 7/8" FROM DOOR EDGE, OTHERWISE DOOR COULD FALL, RESULTING IN SEVERE OR FATAL INJURY.

IMPORTANT: DO NOT SUPPORT THE WEIGHT OF THE DOOR ON ANY PART OF THE REAR BACK HANGS THAT CANTILEVERS 4" OR MORE BEYOND A SOUND FRAMING MEMBER.

NOTE: If rear back hangs are to be installed over drywall, use (2) 5/16" x 2" hex head lag screws and make sure lag screws engage into solid structural lumber.

⚠️ WARNING

FAILURE TO ASSEMBLE AND ATTACH REAR BACK HANGS PROPERLY ACCORDING TO THE ABOVE INSTRUCTIONS MAY RESULT IN DOOR FALLING WHEN RAISED, CAUSING SEVERE OR FATAL INJURY.

NOTE: Perforated angle must be attached to sound framing members and **nails should not be used.**

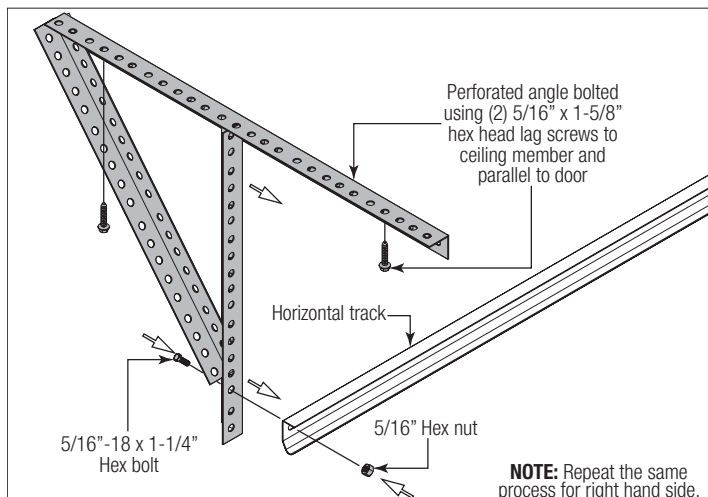
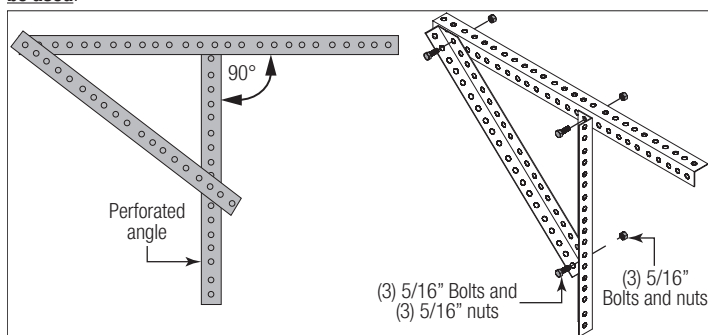

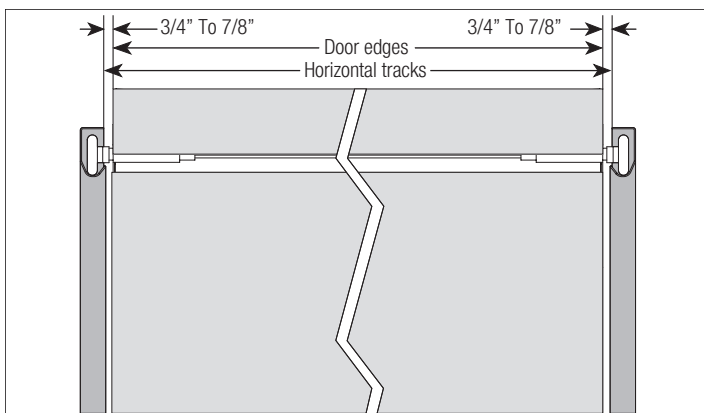

6.) Make sure door is not rubbing on jambs.

IMPORTANT: IF DOOR STILL DOES NOT BALANCE PROPERLY, THEN CONTACT A TRAINED DOOR SYSTEM TECHNICIAN.

22 Attaching Weather Seal

Permanently attach the weatherstrips on both door jambs and header. The weatherstrips were temporarily attached in Preparing the Opening, in the pre-installation section of this manual.

NOTE: When permanently attaching the weatherstrips to the jambs, avoid pushing the weatherstrips too tightly against the face of door.

NOTE: Door not shown for clarity.

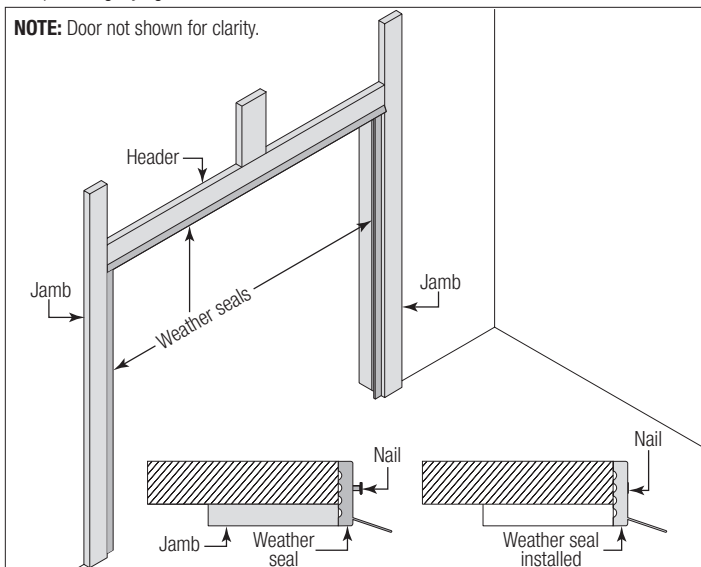

23 Balancing Door

Remove locking pliers. Lift door and check its balance. Adjustments to the required number of spring turns stated may be necessary. If door rises off floor more than 2 ft. under spring tension alone, reduce spring tension. If the door is hard to rise or drifts down on its own, add spring tension. A poorly balanced door can cause garage door operator problems.

To adjust spring tension, fully close door. Apply locking pliers to track above third track roller. Place locking pliers on torsion shaft, as shown in Step Attaching Counterbalance Lift Cables. Insert a winding rod into the winding cone. Push upward on the winding rod slightly while carefully loosening the set screws in the winding cone.

IMPORTANT: BE PREPARED TO SUPPORT THE FULL FORCE OF THE TORSION SPRING ONCE THE SET SCREWS ARE LOOSE.

Carefully adjust spring tension 1/4 turn. Retighten both set screws to 14-15 ft. lbs. of torque in the winding cone and repeat for the other side. Recheck door balance and re-adjust spring tension if needed.

IMPORTANT: DO NOT ADJUST MORE THAN 1 TURN FROM THE RECOMMENDED NUMBER OF TURNS.

If the door still does not operate easily, lower the door into the closed position, unwind spring(s) completely, and recheck the following items:

- 1.) Is the door level?
- 2.) Are the torsion shaft and flag angles / angle mount level and plumb?
- 3.) Does the distance between the flag angles / angle mount equal door width plus 3-3/8" to 3-1/2"?
- 4.) Do the counterbalance lift cables have equal tension? Adjust if necessary.
- 5.) Rewind the spring(s).

Inside Lock

Install the inside lock on the second section of the door. Secure the lock to the section with (4) 1/4" - 20 x 11/16" self drilling screws. Square the lock assembly with the door section, and align with the square hole in the vertical track. The inside lock should be spaced approximately 1/8" away from the section edge.

IMPORTANT: INSIDE LOCK(S) MUST BE REMOVED OR MADE INOPERATIVE IN THE UNLOCKED POSITION IF AN OPERATOR IS INSTALLED ON THIS DOOR.

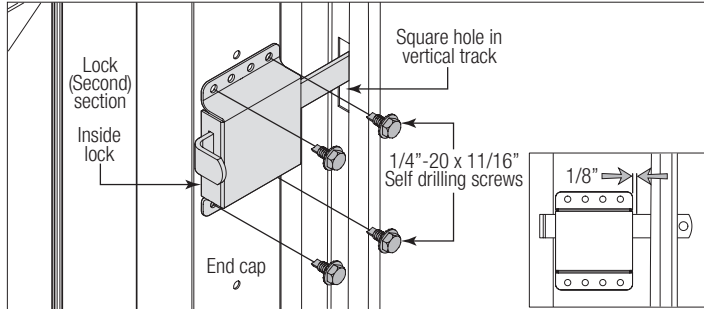

Pull Down Rope

⚠ WARNING

DO NOT INSTALL PULL DOWN ROPE ON DOORS WITH OPERATORS. CHILDREN MAY BECOME ENTANGLED IN THE ROPE CAUSING SEVERE OR FATAL INJURY.

Measure and mark the jamb approximately 48" to 50" (1220 to 1270 mm) from floor on the right or left side of jamb. Drill 1/8" pilot hole for no. 6 screw eye. Tie the pull down rope to the no. 6 screw eye and to the bottom corner bracket, as shown.

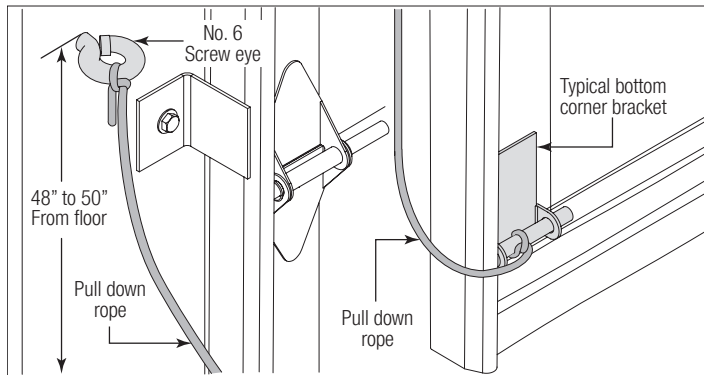

Cleaning Your Garage Door

IMPORTANT: DO NOT USE A PRESSURE WASHER ON YOUR GARAGE DOOR!

While factory-applied finishes on garage doors are durable, it is desirable to clean them on a routine basis. Some discoloration of the finish may occur when a door has been exposed to dirt-laden atmosphere for a period of time. Slight chalking may also occur as a result of direct exposure to sunlight. Cleaning the door will generally restore the appearance of the finish. To maintain an aesthetically pleasing finish of the garage door, a periodic washing of the garage door is recommended.

THE FOLLOWING CLEANING SOLUTION IS RECOMMENDED: A mild detergent solution consisting of one cup detergent (with less than 0.5% phosphate) dissolved into five gallons of warm water will aid in the removal of most dirt.

NOTE: The use of detergents containing greater than 0.5% phosphate is not recommended for use in general cleaning of garage doors.

NOTE: Be sure to clean behind weatherstrips on both sides and top of door.

CAUTION

NEVER MIX CLEANSERS OR DETERGENTS WITH BLEACH.

NOTE: Do not use any window cleaning fluids, scouring compounds, gritty cloths or solvent-based cleaners of any kind.

To clean polycarbonate windows, see www.Wayne-Dalton.com.

Painting Your Garage Door

Refer to Instruction Insert "[Field Painting and Finishing Fiberglass or Steel Door Sections](#)".

Maintaining The Finish On Your Garage Door

If the factory finish is beginning to fade, the door may require a field applied top clear coat. Depending on environment and usage, this may be necessary after 1 to 3 years of use. Refer to Instruction Insert "[Field Painting and Finishing Fiberglass Or Steel Door Sections](#)".

Operation And Maintenance

OPERATING YOUR GARAGE DOOR: Before you begin, read all warning labels affixed to the door and the installation instructions and owner's manual. When correctly installed, your Wayne Dalton door will operate smoothly. Always operate your door with controlled movements. Do not slam your door or throw your door into the open position, this may cause damage to the door or its components. If your door has an electric opener, refer to the owner's manual to disconnect the opener before performing manual door operation below.

MANUAL DOOR OPERATION: For additional information on manual garage door operations go to www.dasma.com and reference TDS 165.

WARNING

DO NOT PLACE FINGERS OR HANDS INTO SECTION JOINTS WHEN OPENING AND/OR CLOSING A DOOR. ALWAYS USE LIFT HANDLES / SUITABLE GRIPPING POINTS WHEN OPERATING THE DOOR MANUALLY.

OPENING A DOOR: Make sure the lock(s) are in the unlocked position. Lift the door by using the lift handles / suitable gripping points only. Door should open with little resistance.

CLOSING A DOOR: From inside the garage, pull door downward using lift handles / gripping point only. If you are unable to reach the lift handles/ suitable gripping points only, use pull down rope affixed to the side of door. Door should close completely with little resistance.

USING AN ELECTRIC OPERATOR:

IMPORTANT: PULL DOWN ROPES MUST BE REMOVED AND LOCKS MUST BE REMOVED OR MADE INOPERATIVE IN THE UNLOCKED POSITION.

When connecting a drawbar (trolley type) garage door operator to this door, a drawbar operator bracket must be securely attached to the top section of the door, along with any struts provided with the door. Always use the drawbar operator bracket supplied with the door. To avoid possible damage to your door, Wayne Dalton recommends reinforcing the top section with a strut (may or may not be supplied). The installation of the drawbar operator must be according to manufacturer's instructions and force settings must be adjusted properly. Refer to the owner's manual supplied with your drawbar operator for complete details on installation, operation, maintenance and testing of the operator.

MAINTAINING YOUR GARAGE DOOR: Before you begin, read all warning labels affixed to the door and the installation instructions and owner's manual. Perform routine maintenance

steps once a month, and have the door professionally inspected once a year. Review your Installation Instructions and Owner's Manual for the garage door. These instructions are available at no charge from Wayne Dalton, a division of Overhead Door Corporation, P.O. Box 67, Mt. Hope, OH., 44660, or at www.Wayne-Dalton.com. For additional information on garage door/operator maintenance go to www.dasma.com and reference TDS 151, 167 and 179.

Monthly Inspections:

1. Visual Inspection: Closely inspect jambs, header and mounting surface. Any material found not to be structurally sound must be replaced. It may be necessary to uninstall part or all of the door assembly in order to replace defective material. Refer to the supplemental instructions "Removing an Existing Door / Preparing the Opening" at www.Wayne-Dalton.com. Inspect the spring(s), counterbalance lift cables, track rollers, pulleys, rear back hangs and other door hardware for signs of worn or broken parts. Tighten any loose screws and/or bolts, except on bottom corner brackets or on the counterbalance assembly. Check exterior surface of the door sections for any minor cracks. Verify door has not shifted right or left in the opening. If you suspect problems, contact a trained door system technician.

WARNING

GARAGE DOOR SPRINGS, COUNTERBALANCE LIFT CABLES, BRACKETS, AND OTHER HARDWARE ATTACHED TO THE SPRINGS ARE UNDER EXTREME TENSION, AND IF HANDLED IMPROPERLY, CAN CAUSE SEVERE OR FATAL INJURY. ONLY A TRAINED DOOR SYSTEMS TECHNICIAN SHOULD ADJUST THEM, BY CAREFULLY FOLLOWING THE MANUFACTURER'S INSTRUCTIONS.

WARNING

NEVER REMOVE, ADJUST, OR LOOSEN THE BOLTS, SCREWS AND/OR LAG SCREWS ON THE COUNTERBALANCE (END BEARING BRACKETS, DRUMS OR SPRING SYSTEM) OR BOTTOM CORNER BRACKETS OF THE DOOR. THESE BRACKETS ARE CONNECTED TO THE SPRING(S) AND ARE UNDER EXTREME TENSION. TO AVOID POSSIBLE SEVERE OR FATAL INJURY, HAVE ANY SUCH WORK PERFORMED BY A TRAINED DOOR SYSTEMS TECHNICIAN USING PROPER TOOLS AND INSTRUCTIONS.

TORQUEMASTER® PLUS SPRINGS: Pawl knob(s) (located on the TorqueMaster® end brackets above the door) should be engaged to prevent the door from rapidly descending in case of spring failure or forceful manual operation.

EXTENSION SPRINGS: A restraining cable or other device should be installed on the extension spring (located above the horizontal tracks) to help contain the spring if it breaks.

2. Door Balance: Periodically test the balance of your door. If you have a garage door drawbar operator, use the release mechanism so you can operate the door by hand when doing this test. Start with the door in the fully closed position. Using handles or suitable gripping points, lift the door to check its balance. Adjust TorqueMaster® or Extension spring(s), if door lifts by itself (hard to pull down) or if door is difficult to lift (easy to pull down). DO NOT attempt to repair or adjust Torsion Springs yourself. To adjust TorqueMaster® or Extension spring(s), refer to your installation instructions and owner's manual. If in question about any of the procedures, do not perform the work. Instead, have it adjusted by a trained door systems technician.

3. Lubrication: The door should open and close smoothly. Ensure the door track rollers are rotating freely when opening and closing the door. If track rollers do not rotate freely, clean the door tracks, removing dirt and any foreign substances. Clean and lubricate (use a non-silicon based lubricant) graduated end hinges, center hinges, steel track rollers, bearings and torsion springs (torsion spring coil surfaces). DO NOT lubricate plastic idler bearings, nylon track rollers, door track. DO NOT oil a cylinder lock, if actuation is difficult use a graphite dust to lubricate.

CHECK FOR PRESENCE OF SAFETY LABELS:

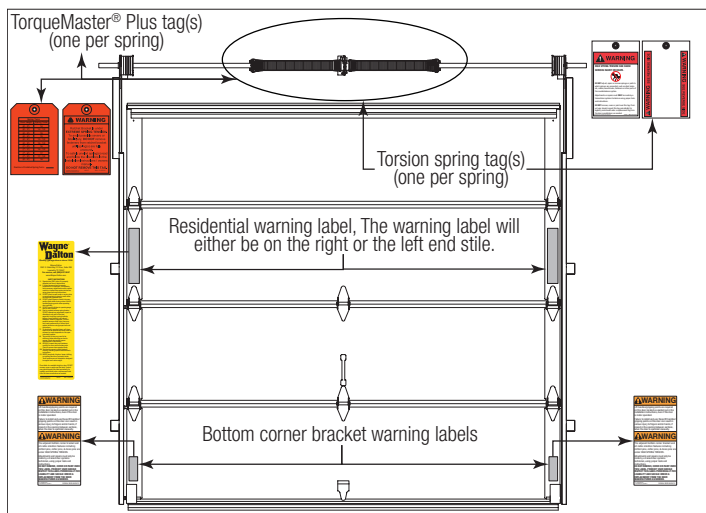



Models 8000, 8100, 8200, 8024 PO, 8124 PO, & 8224 PO

Limited Warranty

Wayne Dalton, a division of Overhead Door Corporation ("Seller") warrants to the original purchaser of the Models 8000, 8100, 8200, 8024 PO, 8124 PO, 8224 PO ("Product"), subject to all of the terms and conditions hereof, that the Product and all components thereof will be free from defects in materials and workmanship for the following period(s) of time, measured from the date of installation:

TEN (10) YEARS from the date of installation against:

- o The Product becoming inoperable due to rust-through of the steel skin from the core of the Product section, due to cracking, splitting, or other deterioration of the steel skin, or due to structural failure caused by separation or degradation of the foam insulation.
- o Peeling of the original paint as a result of a defect in the original paint or in the application of the original paint coating.

TEN (10) YEARS on Product hardware and tracks (except springs).

ONE (1) YEAR on all other component and parts.

Seller's obligation under this warranty is specifically limited to repairing or replacing, at its option, any part which is determined by Seller to be defective during the applicable warranty period. Any labor charges are excluded and will be the responsibility of the purchaser.

This warranty gives you specific legal rights, and you may also have other rights which vary from state to state. This warranty is made to the original purchaser of the Product only, and is not transferable or assignable. This warranty applies only to Product installed in a residential or other non-commercial application. It does not cover any Product installed in commercial or industrial building applications. This warranty does not apply to any unauthorized alteration or repair of the Product, or to any Product or component which has been damaged or deteriorated due to misuse, neglect, accident, failure to provide necessary maintenance, normal wear and tear, acts of God, or any other cause beyond the reasonable control of Seller or as a result of having been exposed to toxic or abrasive environments, including blowing sand, salt water, salt spray and toxic chemicals and fumes.

ALL EXPRESS AND IMPLIED WARRANTIES FOR THE PRODUCT, INCLUDING BUT NOT LIMITED TO ANY IMPLIED WARRANTIES OF MERCHANTABILITY AND FITNESS FOR A PARTICULAR PURPOSE, ARE LIMITED IN TIME TO THE APPLICABLE WARRANTY PERIOD REFLECTED ABOVE. NO WARRANTIES, WHETHER EXPRESS OR IMPLIED, WILL APPLY AFTER THE LIMITED WARRANTY PERIOD HAS EXPIRED. Some states do not allow limitations on how long an implied warranty lasts, so the above limitation may not apply to you.

IN NO EVENT SHALL SELLER BE RESPONSIBLE FOR, OR LIABLE TO ANYONE FOR, SPECIAL, INDIRECT, COLLATERAL, PUNITIVE, INCIDENTAL OR CONSEQUENTIAL DAMAGES, even if Seller has been advised of the possibility of such damages. Such excluded damages include, but are not limited to, loss of use, cost of any substitute product, or other similar indirect financial loss. Some states do not allow the exclusion or limitation of incidental or consequential damages, so the above limitation or exclusion may not apply to you.

Claims under this warranty must be made promptly after discovery, within the applicable warranty period, and in writing to the authorized distributor or installer whose name and address appear below. The purchaser must allow Seller a reasonable opportunity to inspect any Product claimed to be defective prior to removal or any alteration of its condition. Proof of the purchase and/or installation date, and identification as the original purchaser, may be required. There are no established informal dispute resolution procedures of the type described in the Magnuson-Moss Warranty Act.

SELLER: _____

SELLER'S ADDRESS: _____

Thank you for your purchase.

PLEASE DO NOT RETURN THIS PRODUCT TO THE STORE

If you need assistance, please call 1-866-569-3799 (press Option 1) and follow the prompts to contact a customer service representative. They will be happy to handle any questions that you may have.

After installation is complete, leave this Installation Instructions And Owner's Manual with the homeowner, or fasten it near garage door for easy reference.