

# WayneGard Series

## QI Vertical Track Assembly

### Models: 9100/9600/9900

### Installation Instructions Insert

MT. HOPE / PENSACOLA PRODUCTION

Use this insert in conjunction with the installation manual provided with the door. Replace the corresponding steps in this insert with the steps in the installation manual. New jamb brackets for all door heights and for 8'0" 5 section doors, flagangle has changed.

#### 8'0" 5 SECTION ONLY

### ① Attaching Adjustable Flagangle to Quick Install Vertical Track

Hand tighten the flagangle to the vertical track using a stud plate and (2) 1/4 - 20 flange hex nuts (see **Fig. 1**). Secure the flange nuts after flagangle spacing is complete (Steps 10A - 10B)

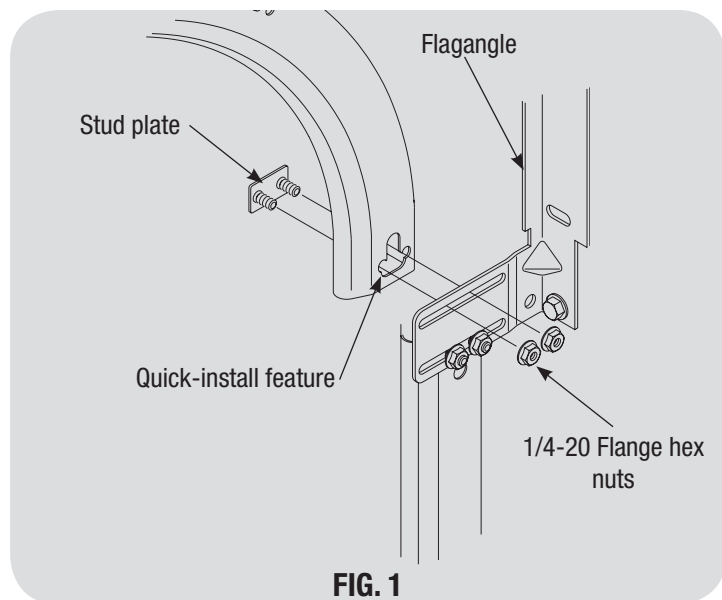

FIG. 1

#### 8'0" 5 SECTION ONLY

### ⑪ Attaching Adjustable Flagangle to Quick Install Horizontal Track

To install horizontal track, place the curved end over the top roller. Align the bottom of the horizontal track with the top of vertical track. Secure the track to the flagangle with (1) stud plate and (2) flange hex nuts (see **Fig. 2**).

Continue **Step 11** in the main door installation manual provided with the door.

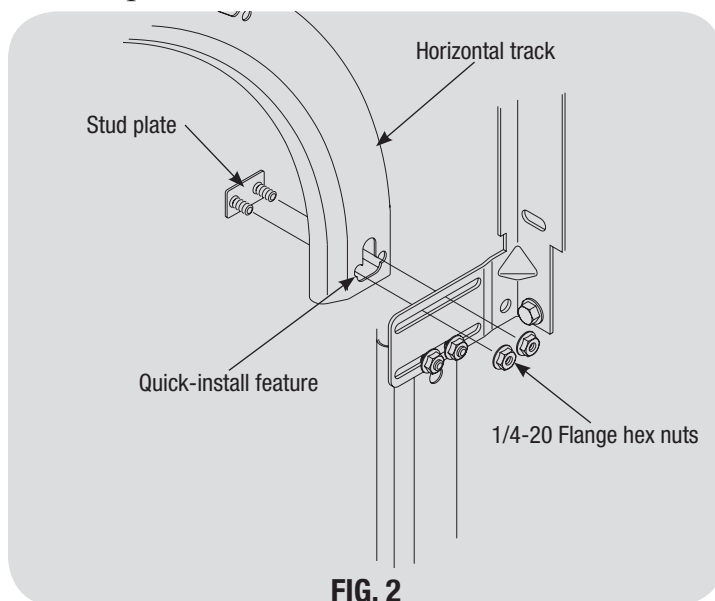

FIG. 2

### ③ Installing the Q.I. Jamb Brackets

Measure the length of the vertical tracks. Using the jamb bracket schedule (located on reverse side), determine the placement of the jamb brackets for your door height and track type. Install the jamb brackets into the appropriate hole at their respective locations (see **Fig. 3** on reverse side).

**BMW QUICK INSTALL TRACK - STANDARD LIFT**

DOOR HEIGHT	1ST SET		2ND SET		3RD SET	
	JAMB BRACKET	POSITION	JAMB BRACKET	POSITION	JAMB BRACKET	POSITION
6'0", 64" TRACK (1626 mm)	QIJB - 5	MIDDLE	QIJB - 6	BOTTOM	NOT APPLICABLE	
6'5", 69" TRACK (1753 mm)	QIJB - 3	BOTTOM	QIJB - 6	MIDDLE	NOT APPLICABLE	
6'8", 72" TRACK (1829 mm)	QIJB - 3	BOTTOM	QIJB - 6	MIDDLE	NOT APPLICABLE	
7'0", 76" TRACK (1930 mm)	QIJB - 3	BOTTOM	QIJB - 7	TOP	NOT APPLICABLE	
7'3", 79" TRACK (2007 mm)	QIJB - 3	BOTTOM	QIJB - 5	BOTTOM	QIJB - 6	BOTTOM
7'6", 82" TRACK (2083 mm)	QIJB - 3	BOTTOM	QIJB - 5	BOTTOM	QIJB - 6	BOTTOM
7'9", 85" TRACK (2159 mm)	QIJB - 3	BOTTOM	QIJB - 5	BOTTOM	QIJB - 6	BOTTOM
8'0", 4 SECT, 88" TRACK (2235 mm)	QIJB - 3	MIDDLE	QIJB - 6	TOP	QIJB - 7	MIDDLE
8'0", 5 SECT, 88" TRACK (2235 mm)	QIJB - 3	BOTTOM	QIJB - 7	TOP	QIJB - 8	TOP

**BMW QUICK INSTALL TRACK - LHR**

DOOR HEIGHT	1ST SET		2ND SET		3RD SET	
	JAMB BRACKET	POSITION	JAMB BRACKET	POSITION	JAMB BRACKET	POSITION
6'0", 57-3/4" TRACK (1467 mm)	QIJB - 5	MIDDLE	QIJB - 8	TOP	NOT APPLICABLE	
6'5", 62-3/4" TRACK (1594 mm)	QIJB - 3	BOTTOM	QIJB - 7	MIDDLE	NOT APPLICABLE	
6'8", 66" TRACK (1676 mm)	QIJB - 3	BOTTOM	QIJB - 6	MIDDLE	NOT APPLICABLE	
7'0", 69-1/2" TRACK (1765 mm)	QIJB - 3	BOTTOM	QIJB - 6	MIDDLE	NOT APPLICABLE	
7'3", 72-1/2" TRACK (1842 mm)	QIJB - 3	BOTTOM	QIJB - 7	TOP	QIJB - 8	TOP
7'6", 75-1/2" TRACK (1918 mm)	QIJB - 3	BOTTOM	QIJB - 7	TOP	QIJB - 8	TOP
7'9", 78-1/2" TRACK (1994 mm)	QIJB - 3	BOTTOM	QIJB - 7	TOP	QIJB - 8	TOP
8'0", 4 SECTIONS 81-1/2" TRACK (2070 mm)	QIJB - 3	BOTTOM	QIJB - 7	TOP	QIJB - 8	TOP
8'0", 5 SECTIONS 82" TRACK (2083 mm)	QIJB - 3	BOTTOM	QIJB - 7	TOP	QIJB - 8	TOP

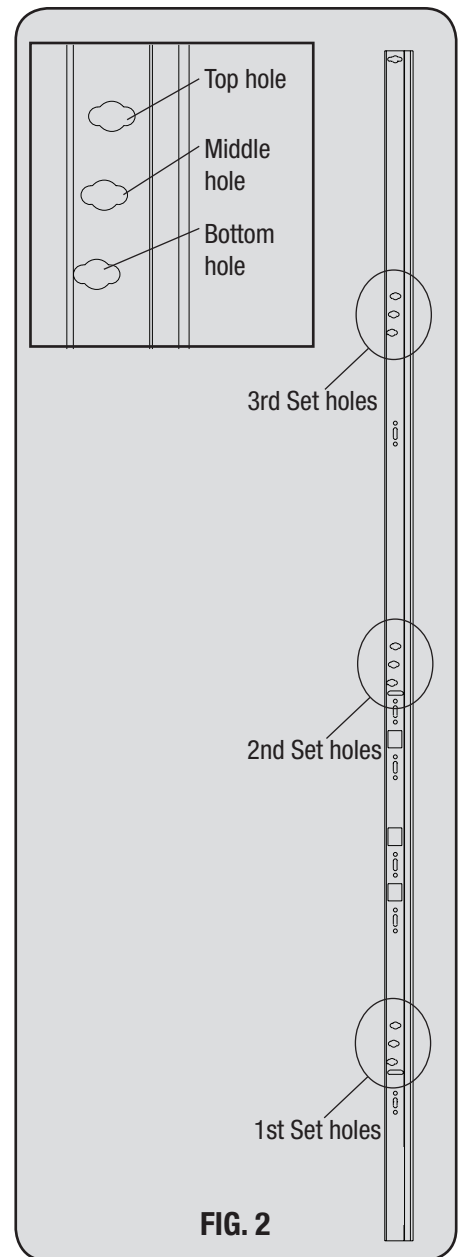

**FIG. 2**